

3-Way Solenoid Valve

Isolating Membrane type

This solenoid valve is an isolated type with an Elastomeric membrane that hermetically isolates the solenoid actuator from the fluid, making it less sensitive to abrasive or contaminated fluids thus providing a safe, and long-life operation. The unique pivoted armature switching mechanism does not require a minimum operating pressure and is unaffected by its mounting position.

The solenoids coil is continuous duty design and is encapsulated in a compact Epoxy construction that is suited for corrosive environments. The 3-way solenoid valve, Isolating Membrane type is suitable for activating BERMAD Deluge or other water Control Valves using freshwater, corrosive, contaminated fluids or air.

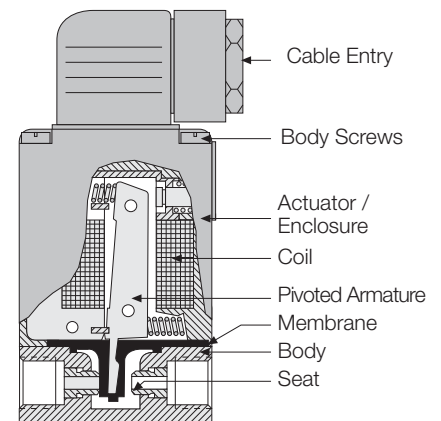

Note: Image & Illustrations are for display only

Features

- No mechanical wetted parts
- Solenoid isolated from fluid
- Suitable for freshwater/seawater or air
- Stainless Steel 316 construction

Power

- 8 Watts, 24V DC or 120, 220 VAC /50-60 Hz.
- Tolerance: ±10%

Materials

- Body: Brass or Stainless Steel 316L
- Internals: Stainless steel
- Elastomeric Membrane: NBR
- Enclosure: Molded Epoxy

Temperature

- Nominal Ambient(1): 0.5° to 50°C (33° to 125°F)
- Maximum Fluid: 80°C (176°F)

Notes:

(1) Max. ambient temperature is determined under continuously energized conditions.

Installation and Maintenance

The Solenoid Valve is the most critical unit in the Deluge system, it should be installed and wired by qualified and trained personnel only.

The coil should be wired in accordance with the requirements of the applied norm such as NEC, NEMA, IEC, or ATEX codes. Ensure that the voltage supply and frequency corresponds with the marking that appear on the enclosure label.

After installation, the cable or conduit must be well supported to avoid excessive load on the conduit hub.

Warning: The solenoid enclosure bolts must not be loosened or disassembled. Loosening or disassembling the solenoid enclosure may result in changing of the factory seal adjustment and may effect the proper operation of the valve, rendering void the warranty and the manufacture liability.

This product shall be wired by an authorized electrician only. The conduit hub on the enclosure must be supported against torque during the assembly using appropriate tools. While tightening a fitting into the conduit hub, attention must be paid that a max. torque of 20Nm is not exceeded.

Maintenance: Proper operation of the Solenoid Valve should be periodically verified.

Testing and Maintenance should be done according to the IOM (Installation Operation & Maintenance) Manual for the specific Bermad Valve in use. It is recommended that the Solenoid Valve be inspected monthly for proper wiring and for leakage. The Solenoid valve must be Tested Annually. It must be operated when maximum system working conditions are applied to simulate the extreme conditions. The unit should be replaced if a malfunction occurs.

Circuit Function

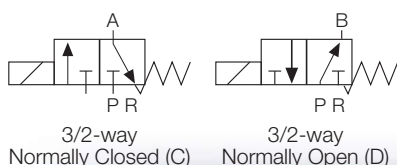

BERMAD Fire Protection

3-Way Solenoid Valve with Isolated Membrane

Solenoids

Technical Data

General purpose, model O330-GP

This solenoid valve is used in non-classified locations where no special certification is required. It is rated for IP 65 ingress protection, continuous duty design with class F coil insulation. This type is equipped with integral cable plug to ISO 4400 (DIN connector) of PA material, including screw terminals (max. 0.75 mm² lead), including gland for 5-6 mm cable entry.

UL-Listed, model O330-UL

This solenoid valve is UL certified, to be installed on Bermad UL-Listed valves, it is also FM approved to be used in Class I Division 2, T4 to NEC 500 hazardous locations, where flammable materials are present abnormally. It is rated for IP 65 ingress protection, continuous duty design with class F coil insulation. This type is equipped with integral cable plug type 2509 of PA material, including screw terminals (max. 0.75 mm² lead), with 1/2" NPT cable entry.

Exproof NEC Div. I, model O330-EX

This Explosion proof solenoid valve is UL certified to be installed on Bermad UL-Listed valves, FM approved to be used in Class I Div. 1 and 2 Groups A, B, C, D and Class II Groups E, F, G hazardous locations according to ANSI/NFPA 70, NEC 500, where hazardous materials are present intermittently. The solenoid enclosure is watertight, NEMA 4, 7, 9 rated, continuous duty design with T4 class F coil insulation. This type is provided with flying leads and 1/2" NPT metal conduit hub.

Special Versions

This solenoid valves are Plunger type (non-isolated). These valves include ATEX certified enclosures, which are not available with the Isolated Membrane type.

Solenoid Valve Selection Table

Isolated Membrane type

Model	Normally	Body Material	Enclosure Type/Class	Code	Cable Entry	Ports Size	Orifice mm	Pres. Bar	Power Watts	Approval See Notes
O330C-GP	N.C.	Brass	IP 65	-	DIN Plug	1/4	2	16	8	(1)
O330C-UL		Brass	Div. 2	-	1/2" NPT, Plug	1/4	2	16	8	UL/FM (2)
O330C-EX		Brass	Div. 1	7	1/2" NPT	1/4	2	16	8	UL/FM (2),(3)
O330C-GP		SS316	IP 65	-	DIN Plug	1/4	2	16	8	(1)
O330C-UL		SS316	Div. 2	-	1/2" NPT, Plug	1/4	2	16	8	UL/FM (2)
O330C-EX		SS316	Div. 1	7	1/2" NPT	1/4	2	16	8	UL/FM (2),(3)
O330D-GP	N.O.	Brass	IP 65	-	DIN Plug	1/4	2	16	8	(1)
O330D-UL		Brass	Div. 2	-	1/2" NPT, Plug	1/4	2	16	8	UL/FM (2)
O330D-EX		Brass	Div. 1	7	1/2" NPT	1/4	2	16	8	UL/FM (2),(3)
O330D-GP		SS316	IP 65	-	DIN Plug	1/4	2	16	8	(1)
O330D-UL		SS316	Div. 2	-	1/2" NPT, Plug	1/4	2	16	8	UL/FM (2)
O330D-EX		SS316	Div. 1	7	1/2" NPT	1/4	2	16	8	UL/FM (2),(3)

Special Versions

Model	Normally	Body Material	Enclosure Type/Class	Code	Cable Entry	Ports Size	Orifice mm	Pres. Bar	Power Watts	Approval See Notes
6014C-ia	N.C.	Brass	EEx ia IIC T6	8	DIN Plug	1/4	2	10	0.4	(1), (4)
6014D-EExm	N.O.	Brass	EEx m II T4	8	PA Cable Gland	1/4	2	16	8	(1), (4)

Notes:

- (1) General purpose / watertight, IP 65 Ingress Protection to IEC Spec.
- (2) UL-Listed for Fire Protection Special Systems (UL429A). FM Approved for Class I, Div 2, Groups A, B, C, D
- (3) FM Approved for hazardous locations Class I, Division 1, Groups A, B, C, D; Class II Gr. E, F, G
- (4) ATEX Certified for hazardous locations
- (5) Specifications subject to change without notice.
- (6) used only with Pneumatic pressure actuation.

