

Differential Pressure Sustaining Valve

Model: FP 436



Description

The Model FP 436 Differential Pressure Sustaining Valve is a hydraulically operated, diaphragm actuated, control valve that sustains a minimum pre-set, differential pressure between two points regardless of fluctuating flow or varying upstream pressure.

Typical Applications



Pump overload & cavitation protection



Safeguarding pump minimum flow

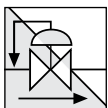

Emergency filter by-pass

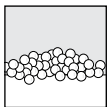

Foam recirculation; maintains required foam pressure



Balancing between circuits in systems

Features and Benefits

- **Hydraulically powered valve design**
 - Closes drip tight time after time
 - Eliminates jamming problems
- **Hydro-efficient body design**
 - Wide rangeability
 - Unrestricted flow path
- **One-piece molded elastomeric moving part –**
No maintenance required
- **Simple design –** Cost effective
- **Factory pre-assembled trim –** Out-of-box quality
- **In-line serviceable –** Minimal down time

Optional Features

- **Large control filter** (code: F)
- **Valve position flow indicator**
- **Seawater service construction**
- **Valve Position Single/Double Limit Switches**

Note: Optional features can be mixed and matched.
Consult your local BERMAD representative for full details

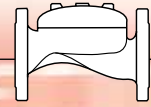

Operation

The BERMAD Model FP 436 is a pilot controlled valve equipped with an adjustable, 2-Way, Differential Pressure Sustaining Pilot. The needle valve [1] which controls the closing speed, continuously allows flow from valve inlet into the control chamber [2]. The pilot [3], locally or remotely, senses both high pressure below its diaphragm and low pressure above it. Should differential pressure fall below pilot setting, the pilot throttles, enabling pressure to accumulate in the control chamber, causing the main valve to throttle, sustaining differential pressure at the pilot setting.

Should differential pressure rise above pilot setting, the pilot releases accumulated pressure causing the main valve to modulate open.

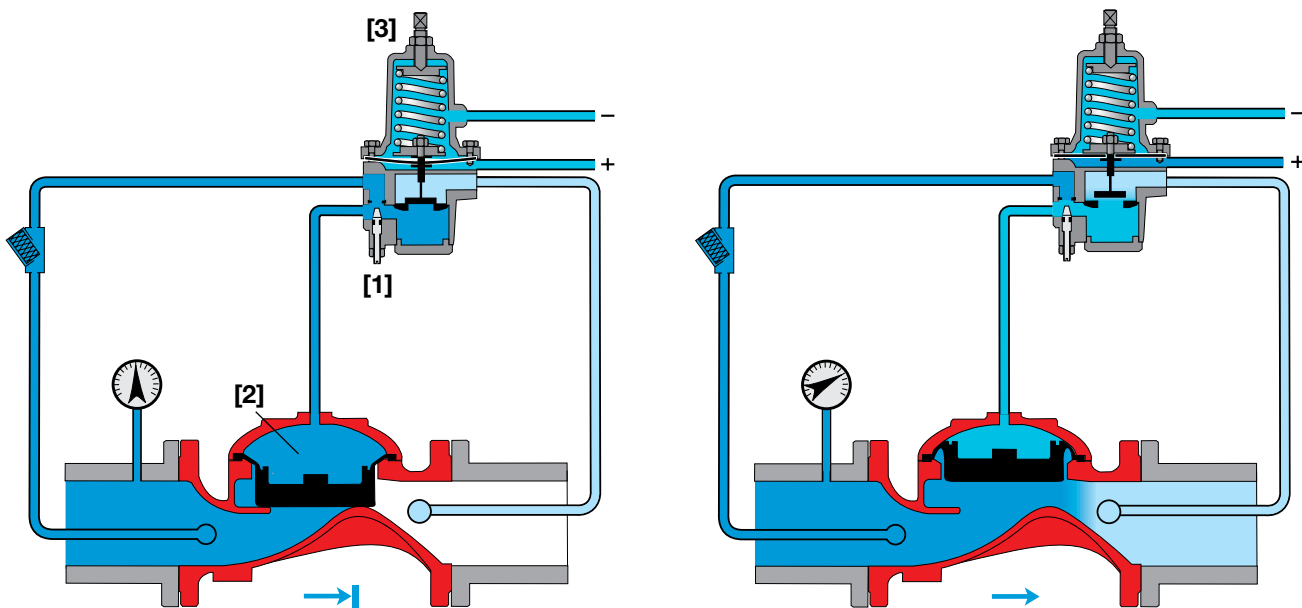

Valve Closed (static condition)

Valve Modulate (flowing condition)

Engineer Specifications

The Differential Pressure Sustaining Valve shall sustain a minimum pre-set, differential pressure between two points regardless of fluctuating flow or varying upstream pressure.

The main valve shall be an elastomeric type globe (or angle) valve with a rolling-diaphragm. Valve actuation shall be accomplished by a fully peripherally supported, one-piece balanced rolling-diaphragm, vulcanized with a rugged radial seal disk. The diaphragm assembly shall be the only moving part.

The valve shall have an unobstructed flow path, with no stem guide or supporting ribs.

The valve shall have a removable cover for quick in-line service enabling all necessary inspection and servicing.

The pilot system shall be field adjustable, with adjustable valve closing speed integrated into the main valve, hydraulically tested and supplied as an assembly consisting of:

- Differential Pressure Sustaining Pilot Valve as part of the assembly with built-in, internal needle valve
- "Y" strainer

The control trim shall be supplied as an assembly, pre-assembled and hydraulically tested at an ISO 9000 and 9001 certified factory.

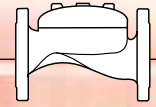

Typical Installations

Emergency Filter By-pass

In filtration systems there are two cases in which by-passing the filter is essential:

- Blocked filter
(potentially causing element collapse)
- Demand for Emergency Fire water

The Model FP 436, installed as a by-pass, progressively compensates for excessive demand.

Adding feature "S" incorporates alarm signaling attribute.

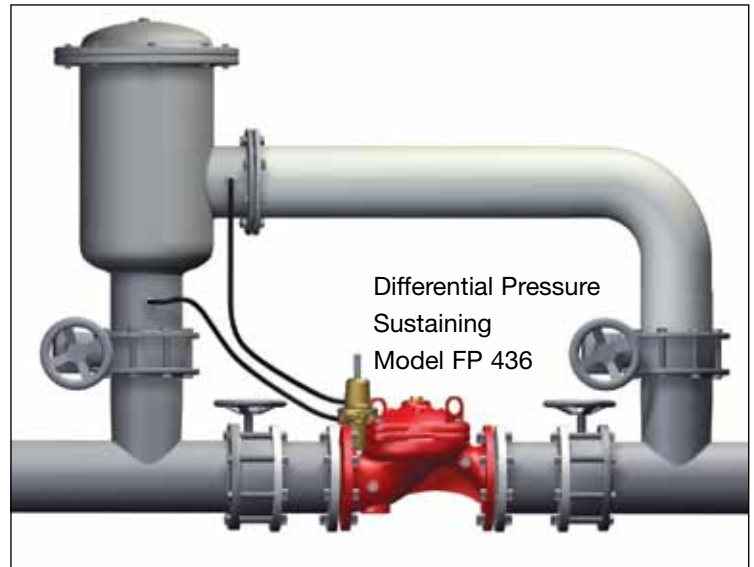

Pump Overload & Cavitation Protection

Where suction pressure regimes vary, the Model FP 436 is needed to limit pump flow by sustaining pump differential pressure, and preventing pump overload and cavitation damage caused by excessive demand.

Adding check feature "20", saves the cost of a line sized check valve.

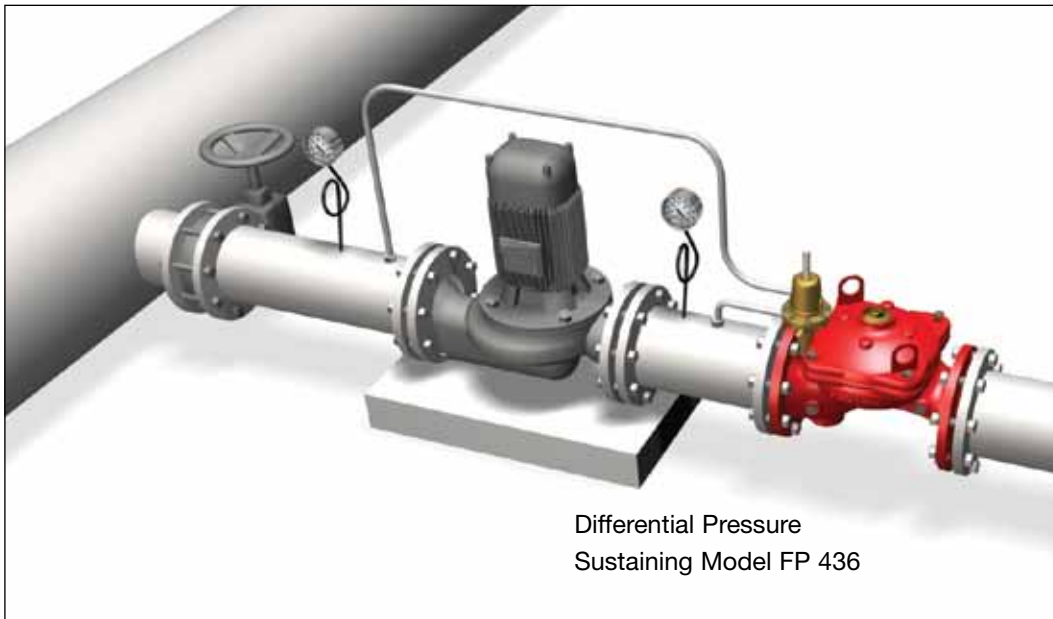

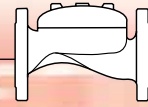

Technical Data

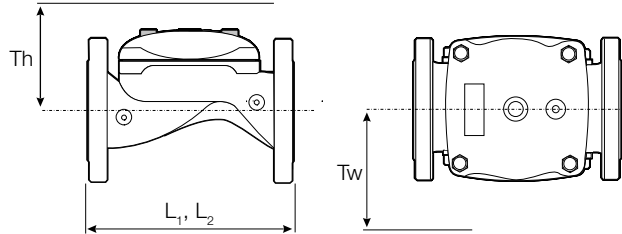

Size	2"		2½"		3"		4"		6"		8"		10"		12"		
	mm	inch	mm	inch	mm	inch	mm	inch	mm	inch	mm	inch	mm	inch	mm	inch	
Dimensions	L ₁ ⁽¹⁾	205	8½	205	8½	257	10⅞	320	12 ⁹ / ₁₆	415	16 ⁵ / ₁₆	500	19 ¹¹ / ₁₆	605	23 ¹³ / ₁₆	725	28½
	L ₂ ⁽²⁾	180	7 ¹ / ₁₆	210	8¼	255	10 ¹ / ₁₆	N/A	N/A	N/A	N/A	500	19 ¹¹ / ₁₆	N/A	N/A	N/A	N/A
	Tw	284	11 ³ / ₁₆	284	11 ³ / ₁₆	300	11 ³ / ₁₆	313	12 ⁵ / ₁₆	341	13 ⁷ / ₁₆	415	16 ⁵ / ₁₆	443	17 ⁷ / ₁₆	481	18 ¹⁵ / ₁₆
	Th	210	8¼	210	8¼	215	8 ⁷ / ₁₆	243	9 ⁹ / ₁₆	315	12 ³ / ₈	350	13¾	382	15	430	6 ¹⁵ / ₁₆

Notes:

- L₁ is for flanged valves.
- L₂ is for threaded NPT or ISO-7-Rp.
- Tw & Th are max. for pilot system.
- Data is for envelope dimensions, component positioning may vary.
- Provide space around valve for maintenance.

Connection Standard

- Flanged: ANSI B16.42 (Ductile Iron), B16.5 (Steel & Stainless Steel), B16.24 (Bronze)
 - ISO PN16
 - Grooved: ANSI/AWWA C606 for 2, 3, 4, 6 & 8"
- Water Temperature**
- 0.5 – 50°C (33 – 122°F)

Available Sizes

- Globe: 2, 2½, 3, 4, 6, 8, 10 & 12"
- Angle: 2, 3, & 4"

Standard Pressure Rating

- Max. inlet: 175 psi (12 bar)
- Set: 7 - 90psi (0.5 - 6 bar)
- Test: 365 psi (25 bar)

Approvals

- ABS
- Lloyd's Registered

Manufacturers Standard Materials

Main valve body and cover

- Ductile Iron ASTM A-536

Main valve internals

- Stainless Steel & Elastomer

Control Trim System

- Brass control components/accessories
- Stainless Steel 316 tubing & fittings

Elastomers

- Polyamide fabric reinforced Polyisoprene, NR

Coating

- Electrostatic Powder Coating Polyester, Red (RAL 3002)

Optional Materials

Main valve body and accessories

- Carbon Steel ASTM A-216-WCB
- Stainless Steel 316
- Ni-Al-Bronze ASTM B-148

Control System

- Stainless Steel 316

Coating

- Electrostatic Powder Coating Polyester, Red (RAL 3002)

