

Hydraulic Relay Valve (HRV-2)

The HRV-2 is used as a hydraulic relay pilot valve for local release of the Bermad's deluge valve control chamber. It is held closed by the water pressure applied through the solenoid valve or by the wet pilot line. It is UL Listed when installed as part of the control trim of deluge valves.

Materials

Body

- Nickel plated Brass
- Stainless Steel 316

Elastomers

- NBR

Wetted Parts

- Brass
- Stainless Steel 316

Orifice

- 3/8" (9 mm)

Pressure Rating

- 21 bar (300 psi)

Temperature

- Water upto 80°C (180°F)

Flow factor

- KV 1.3 (CV 1.5)

End Connections

- 3/8" NPT

Approvals

- UL Listed

Note: when installed on specific Bermad Deluge Valve



Brass Construction



Corrosion Resistant Construction

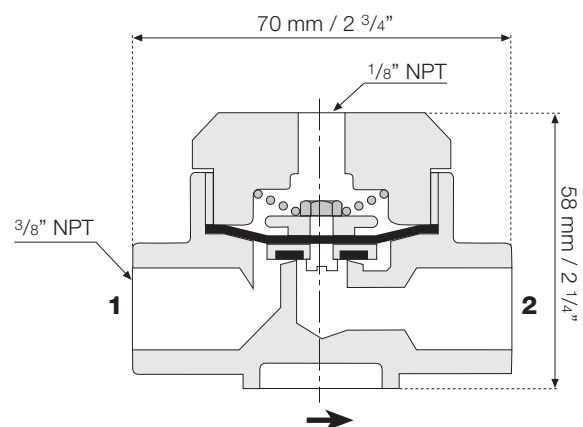

Weight (Brass): 0.6 Kg / 1.3 lbs.