

Level Control Valve with Bi-Level Vertical Float & Closing Surge Prevention

(Sizes 1½-24"; DN40-600)

Description

The Model 750-66-49-B Level Control Valve with Bi-Level Vertical Float & Closing Surge Prevention is a hydraulically operated, diaphragm actuated, double chambered control valve. The valve is hydraulically powered to fully open at pre-set reservoir low level, and to shut off at pre-set high level regardless of valve differential pressure. The 750-66-49-B is equipped with an additional pilot which neutralizes system pressure-rise, normally caused by valve closing process.

Installation

1. Ensure enough space around the valve assembly for future maintenance and adjustments.
2. Prior to valve installation, flush the pipeline to insure flow of clean fluid through the valve.
3. For future maintenance, install Isolation gate valves upstream and downstream from Bermad control valve.
4. Install the valve in the pipeline with the valve flow direction arrow in the actual flow direction. Use the lifting ring provided on the main valve cover for installing the valve.
5. For best performance, it is recommended to install the valve horizontally and upright. For different valve positions – consult Bermad.
6. Install the float pilot assembly either at an external balancing tank or at an internal stilling tank (refer to the enclosed "Float #66" catalog page).
7. Pull three parallel ½" or ¾" control tubes, from the valve to the float. Mark each of the tubes at both sides for identification.
8. It is highly recommended to install a strainer Bermad model 70F upstream from the pressure reducing valve, to prevent debris from damaging valve operation.
9. Determine the desired rod length according to level differential between the float assembly and reservoir lowest level.
10. Assemble the extension rods to the upper rod and to one another. Apply glue ("Loctite 200" or equivalent) and screw tight. Be careful not to damage the rod.
11. Install the upper & lower stoppers on the rod without the float ball. Use 3/16" Allen-Key to lock the stoppers on the rod.
12. Screw the upper rod to its place at the bottom of the lever system & tighten the lock nut by ½" spanner.
13. Balance the float assembly by moving the weight against the rod and stoppers (without the float ball). After reaching equilibrium, tighten the balancing-weight screw and its lock-nut by 7/16" spanner.
14. Remove the lower stopper to enable threading-in the float ball. Reassemble the lower stopper & lock it in its place.
Note: You may have to pull out the whole rod, in order to reach the lower stopper. If so, release the rod lock-nut, unscrew the installed rod (with its extensions & the stoppers) and pull it up from the stilling tank. After threading-in the float ball and locking the lower stopper back in its place, reassemble the installed rod.
15. Connect the control tubes ends, using ¾" copper or reinforced plastic tube, to the valve and to the float according to control drawing below.
 - 15.1. Tube from valve control filter [4] or (for 10" & larger) [4.1] to float port [P].
 - 15.2. Tube from float port [C1] to valve cover or (for 10" & larger) to accelerator [54B].
 - 15.3. Tube from float port [C2] to valve lower chamber or (for 10" & larger) to accelerator [54B.1].

Commissioning & Calibration

1. Confirm that cock valves [1] and [1.1] are open (handle parallel to cock-valve body).
2. Confirm that the supply pressure is typical.
3. Adjust the water levels by setting the stoppers:
 - 3.1. Hold the lever system at its upper position & set the upper stopper to 100 mm below desired upper level (but not higher than 150 mm below over-flow level).
 - 3.2. Hold the lever system at its lower position & set the lower-stopper to 100 mm above desired lower level.
4. Open upstream and downstream isolating valves. Allow the 750-66-B to open (ensuring the lever system is at its lower position) and start to fill-up the reservoir, while performing the below specified procedure:
 - 4.1. **Calibrating "49" pilot & Venting air from the valve control loop:**

The Model 750-66-49-B is factory set slightly above the maximum system pressure. The set pressure is marked on the pilot's label. If the set pressure is either different from the design or the requirements have been changed, follow the below steps:

 - 4.1.1. Unlock the pilot locking nut and turn the pilot adjusting screw Clock-Wise until fully tighten. This will temporarily eliminate the Closing Surge Prevention feature.
 - 4.1.2. During filling the reservoir move the lever-system manually to its upper position, forcing the valve to close, then to its lower position, forcing the valve to open. At each position, vent air from the valve control loop by loosening tube fitting at the highest point (pilot float ports [P], [C1] & [C2]), allowing the air to bleed. For 10" valves & larger, air venting is required also from the port [2] of both 3W hydraulic Relay valves [54] & [54.1]. Retighten the fittings eyebolts.
 - 4.1.3. Turn the pilot adjusting screw Counter-Clock-Wise until fully open and move again the float lever-system manually to its upper position, forcing the valve to close. The valve should not close.

- 4.1.4. Keep the float lever-system in its upper position & slowly re-turn the pilot adjusting screw Clock-Wise until the 750-66-49-B starts & completes closing. From this point turn the setting screw one more turn Clock-Wise and lock the pilot locking nut.
- 4.2. Calibrating shutting upper-level:
Ensure that the 750-66-49-B closes as the water level reaches the upper set-level. If the 750-66-B has not closed, move the lever-system manually to its upper position, forcing the valve to close. Change the upper stopper location down, to lower level setting or up to raise it, until the valve closes automatically at the desired upper-level.
- 4.3. Calibrating opening lower-level:
Allow the water level to drop by consuming from the reservoir or by draining it. Ensure the 750-66-49-B remains closed until water level reaches the desired lower-level, switches at that point and opens fully. Change the lower stopper location down, to lower level setting or up to raise it, until the valve opens automatically at the desired lower-level
- Note: For switching valve tendency from closing to opening and vice versa, change manually the lever system position up to close and down to open.

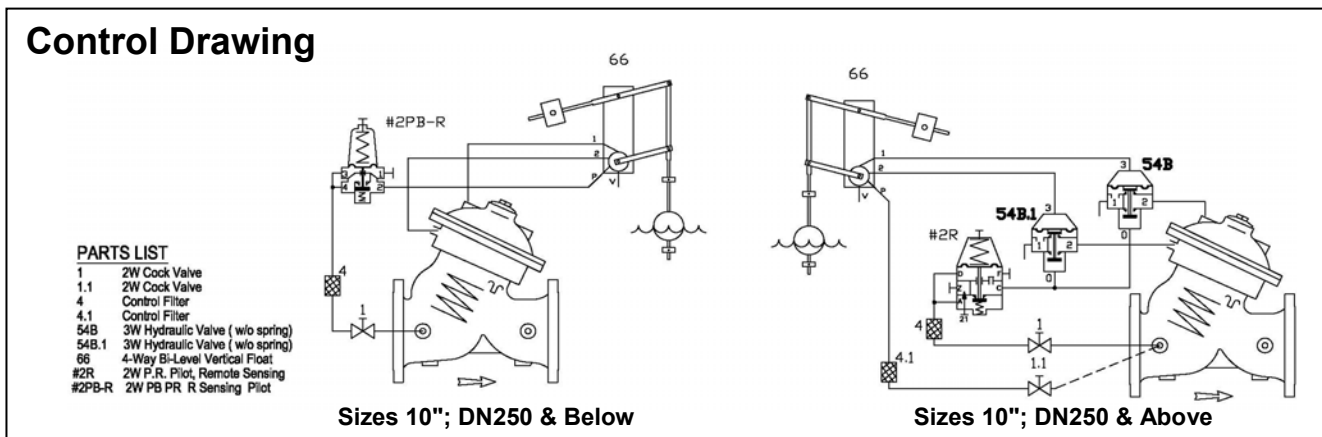

Trouble-Shooting

1. Valve fails to Open: Check for sufficient inlet pressure, confirm float setting & check cock valves status.
2. Valve fails to Close: Confirm float setting, check cock valves status, confirm pilot setting to slightly above maximum system pressure, clean control filter & detect for clogged ports or fittings, check if any debris trapped in the main valve, confirm diaphragm is not leaking.
3. Valve fails to Regulate: Check cock valves status, release air trapped in the 750-66-49-B control chambers & the 3W hydraulic Relay Valves control chambers.

Preventative Maintenance

1. System operating conditions that effect on the valve should be checked periodically to determent the required preventative maintenance schedule.
2. Maintenance instructions:
 - 2.1. Tools required:
 - 2.1.1. Metric and imperial wrenches
 - 2.1.2. Anti seize grease
 - 2.2. Visual inspection to locate leaks and external damages
 - 2.3. Functional inspection including: closing, opening and regulation.
 - 2.4. Close upstream and downstream isolating valves (and external operating pressure when used).
 - 2.5. Once the valve is fully isolated vent pressure by loosening a plug or a fitting.
 - 2.6. Open the stud nuts and remove the actuator as one unit from the valve body. Disassemble necessary control tubs.
 - 2.7. It is highly recommended to stock a reserve actuator assembly for each size. This allows minimum system field work and system down time.
 - 2.8. Disassemble the actuator and examine its parts carefully for signs of wear, corrosion, or any other abnormal conditions.
 - 2.9. Replace worn parts and all the Elastomers. Lubricate the bolts and studs threads with Anti seize grease.

Spare parts

Bermad has a convenient and easy to use ordering guide for valve spare-parts and control system components. For solenoid valves refer to model and S/N on solenoid tags.

Pub # : IOMEW750-66-49-B	By: YE 1/08	Rev: 01YE-1/08	File name: IOMEW750-66-49-B_01_08
--------------------------	-------------	----------------	-----------------------------------



appliceng@bermad.com • www.bermad.com

The information contained in this document is subject to change without notice.

BERMAD shall not be liable for any errors contained herein. All Rights Reserved. © Copyright by BERMAD Control Valves.