



Pressure Reducing Pilot Valve with Remote Adjustable Set Point

Model #2PB-4T

This pilot integrates all principal functions of a 2-Way control circuit in a single assembly. It is a direct-acting valve, actuated by a pressure responsive diaphragm, which tends to reach equilibrium with the set spring force. Pilot setting can be changed remotely using a dedicated control system.

Features

- Fail safe to high setting
- Large range of settings
- Frictionless design
- Internal or external pressure sensing
- Direct pressure gauge installation
- Adjusting screw protecting cover

Typical Applications

- Pressure reducing valves in leakage controlled systems

Technical Data

Pressure Rating: 25 bar (350 psi)

Working Temperature: Water up to 80°C (180°F)

Flow Factor: Kv 0.46 (Cv 0.54)

Standard Materials:

Body: Stainless Steel 316 or Bronze

Covers & Adapter: Anodized Aluminum

Elastomers: NBR (Buna N)

Internals: Stainless Steel & Brass

Spring: Galvanized Steel

Bolts & Nuts: Stainless Steel

Optional Materials:

Metal Parts: Stainless Steel, Nickel Aluminum Bronze, Hastalloy

Elastomers: EPDM, FPM (Viton®)

Adjustment Range

Spring	Pressure	
	bar	psi
G (Standard)	1-10	15-150
M (Optional)	1-16	15-230
N (Optional)	0.5-6	7-90

Remote Adjusting Range

$\Delta P_{set} = Pa \times 5$ (Standard)

$\Delta P_{set} = Pa \times 10$ (Optional)

When:

ΔP_{set} = Max. differential pressure between high and low set points

Pa = Max. pressure available from the control unit

Connections

- 2 - Downstream - 1/4" NPT
- 4 - Valve control chamber - 1/4" NPT
- 1/3 - Remote sensing (optional) or pressure gauge - 1/4" NPT
- T - Remote setting control - 1/8" NPT

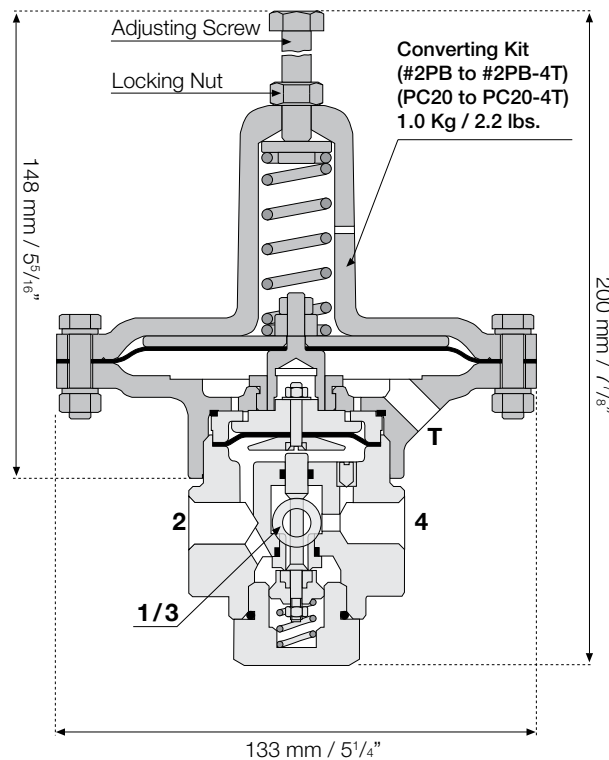

Total weight: 1.9 Kg / 4.2 lbs.



Pressure Reducing Pilot Valve with Remote Adjustable Set Point

Model #2-4T

This pilot integrates all principal functions of a 2-Way control circuit in a single assembly. It is a direct-acting valve, actuated by a pressure responsive diaphragm, which tends to reach equilibrium with the set spring force. Pilot setting can be changed remotely using a dedicated control system. An integral needle valve acts as an upstream flow restrictor as well as a closing speed control.

Features

- Fail safe to high setting
- Large range of settings
- Frictionless design
- Integral needle valve
- Internal or external pressure sensing
- Direct pressure gauge installation
- Adjusting screw protecting cover

Typical Application

- Pressure reducing valves in leakage controlled systems

Technical Data

Pressure Rating: 40 bar (600 psi)

Working Temperature: Water up to 80°C (180°F)

Flow Factor: Kv 1.0 (Cv 1.2)

Standard Materials:

Body: Brass

Covers & Adapter: Anodized Aluminum

Elastomers: NBR (Buna N)

Internals: Stainless Steel & Brass

Spring: Galvanized Steel

Bolts & Nuts: Stainless Steel

Optional Materials:

Metal Parts: Stainless Steel, Nickel Aluminum Bronze, Hastalloy

Elastomers: EPDM, FPM (Viton®)

Adjustment Range

Spring	Pressure	
	bar	psi
10 (Standard)	0.8-8	11-115
16 (Optional)	3-16	45-230

Remote Adjusting Range

$$\Delta P_{set} = P_a \times 5 \text{ (Standard)}$$

When:

ΔP_{set} = Max. differential pressure between high and low set points

P_a = Max. pressure available from the control unit

Connections

Z - Upstream - 1/4" NPT

A - Valve control chamber - 1/4" NPT

C - Downstream - 1/4" NPT

F/D - External sensing/pressure gauge - 1/4" NPT

T - Remote setting control - 1/8" NPT

