



Pressure Sustaining Pilot Valve

Model FP#3UL

This pilot valve integrates all the principal functions of a two-way control circuit into a single assembly. It is a direct acting valve, actuated by a pressure responsive diaphragm, which tends to reach equilibrium with the set spring force. When used in a pressure relief/sustaining circuit, the pilot modulates to open as upstream pressure rises above set point. An integral needle valve acts as an upstream flow restrictor as well as a closing speed control.

Features

- Integral needle valve
- Internal or external pressure sensing
- Differential pressure sensing (Option)

Typical Applications

- Pressure relief valve (Standard model #3)
- Differential Pressure sustaining valve (differential sensing #3D)
- Pump suction control valve (external sensing #3R)

Approvals

- UL-Listed and FM Approved when installed on BERMAD specific valve models

Technical Data

- Pressure Rating: 30 bar (430 psi)
- Working Temperature: Water up to 80°C (180°F)
- Flow Factor: Kv 1.1 (Cv 1.3)

Standard Materials

- Body & cover: Brass
- Elastomers: NBR (Buna N)
- Internals: Stainless Steel & Brass
- Spring: Galvanized Steel

Adjustment Range

Spring	Pressure		Application
	bar	psi	
16	1-16	15-230	Class #150/PN16
10	0.8-10	11-150	43T-06/730R/436/736
30	2-25	30-365	Class #300/PN25

Optional Materials

- All Stainless Steel 316
- Nickel Aluminum Bronze
- Super Duplex 25Cr

Connections

- Z**-Upstream
- A**-Valve control chamber
- C**-Downstream
- F/D**-External sensing/pressure gauge



(for Illustration Only)

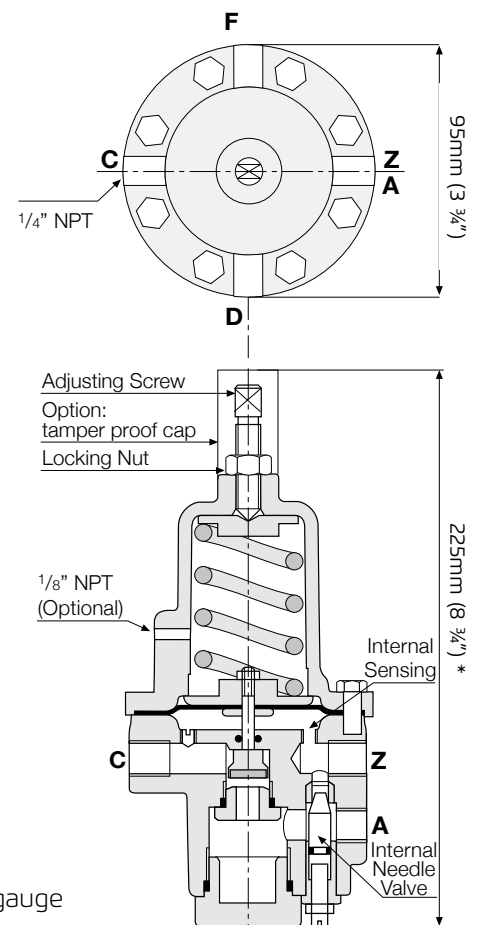

Weight: 2.7 Kg / 6 lbs.

* For spring "30" high pressure type add 15 mm (5/8") to pilot height.