

## General Purpose Pressure Switch

### Model PS-10

The Model PS-10, adjustable, pre-set Pressure Switch is suitable for pressure and/or flow detection in BERMAD valve systems such as Deluge or Pre-action, or with other control valves and is suited for non-hazardous locations. The model PS-10 is also used to provide a low pressure supervisory signal for BERMAD Pre-action Systems and pneumatically controlled deluge valves.

#### Features

- Solid metal enclosure
- IP66 / NEMA 4 watertight and dust proof when used with suitable cable connection
- 20.7 bar (300psi) system pressure rated
- One SPDT or two SPDT version for DPDT action (marked with 2A suffix)
- Convenient field adjustability
- Global approvals
- Reliable and dependable

#### Approvals

- UL-Listed
- FM Approved
- VdS Approved
- CE Marked

#### Materials

- Wetted parts: Polyamide (PA), corrosion resistant
- Cover: Die-Cast Aluminum with textured red powder coat finish
- Base: Die-Cast Aluminum

#### End Connections

- Pressure: ½" NPT (M)
- Electric: ½" Conduit Hole

#### Typical Installation

The Pressure Switch shall be connected to the BERMAD valve alarm discharge piping. Ensure that no shut-off valves are located between the alarm piping and the Pressure Switch. The device should be mounted in an upright position. IP66/NEMA 4 conduit fitting or cable gland is required for outdoor installations.



(for illustration only)

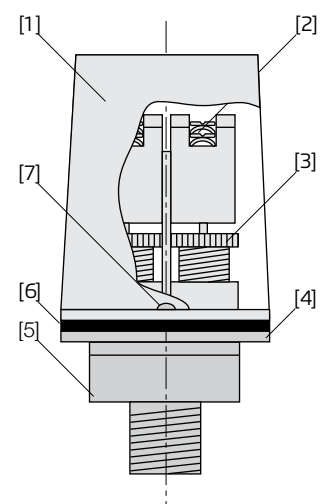

#### Major Parts

- [1] Cover
- [2] Terminal screws
- [3] Adjustment knob
- [4] Base
- [5] Pressure connection
- [6] Gasket
- [7] Cover screw

## Technical Data

### Pressure Rating & Range

- Pressure Rating: 20.7 bar (300 psi)
- Factory set: +/- 1.0 bar (15 psi)
- Adjusting range: 0.3 - 1.4 bar (4 to 20 psi)
- Deadband: 0.13 bar (2psi) typical
- Maximum pressure: 20.7 bar (300 psi)

### Electrical Ratings

- 10 Amps @ 125/250VAC
- 2.0 Amps @ 30VDC
- Single or dual SPDT (from C)

### Enclosure Class

- IP66 / NEMA4 Weather-proof

### Ambient Temperature

- -40°C to 60°C (-40°F to 140°F)

### Weight

- Approx. 0.60kg (21oz)

### Installation - Caution

An uninsulated section of a single conductor should not be looped around the terminal to serve as two separate connections. The wire must be severed, thereby providing supervision of the connection in the event that the wire becomes dislodged from under the terminal.

#### Note:

To prevent leakage, apply teflon tape sealant to male threads only.

#### Warning:

Use of pipe joint cement may result in obstruction of the aperture and loss of signal.

### Testing

Test by opening the water bypass alarm test valve.

**Caution:** The above test might also activate any other circuit closer or water motor gongs that are present on the system.

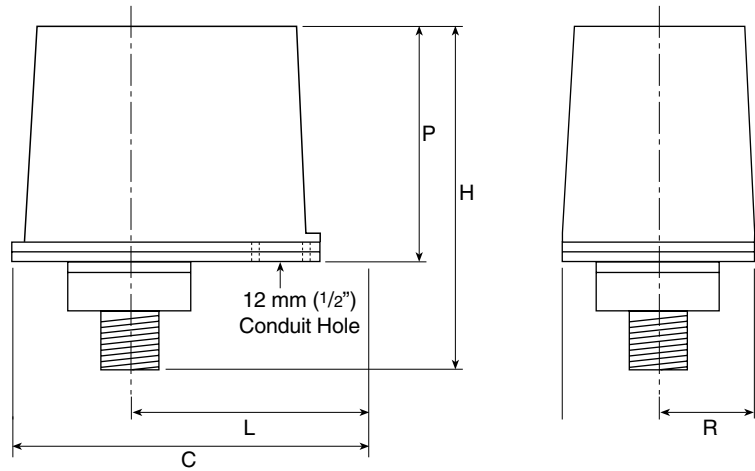

	mm	inch
H	107.2	4.22
P	73	2.87
L	63	2.48
C	96	3.78
R	40.7	1.60

### Typical Electrical Connections

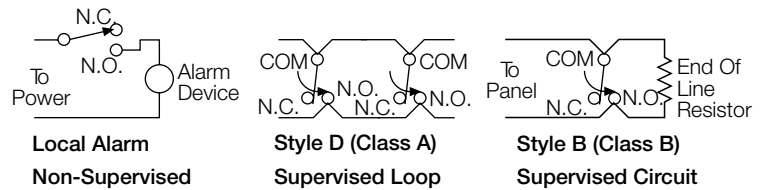

### Pressure Switch Termination

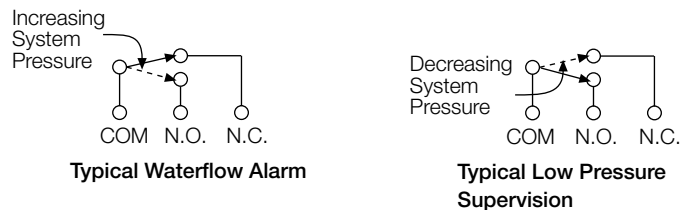

#### Note:

The operation of the PS-10 should be tested upon completion of installation and periodically thereafter in accordance with the applicable NFPA codes and standards and/or the authority having jurisdiction (manufacturer recommends quarterly or more frequently).

