



3-Way Latching Universal Relay Valve Model URV-3-M

The BERMAD URV-3-M Latching Universal Relay Valve is a 3-Way spring return frictionless balanced poppet type, pressure operated and diaphragm actuated latching relay pilot valve.

The URV latching relay valve is designed for use with BERMAD deluge water control and foam concentrate valves, the URV will actuate the BERMAD main valve upon control pressure release from the URV control chamber (the main valve will be "pressure to close")

The URV changes its position in response to pressure being supplied to its control chamber. Once pressure has been released from the control chamber the latching mechanism holds the URV in this last position, regardless of a return of the control pressure. Only after being manually and locally reset by pulling the reset toggle with a simultaneous return of pressure to the URV control chamber will the URV return to its set position.

This latching ability is a safety feature, often a requirement for fire protection deluge valves allowing only a local and intended closure of the main valve.

The URV's balanced-poppet design enables safe reliable operation with a low control pressure using compact dimensions. The URV is specifically designed for Fire Safety systems in that it has no mechanical friction of the internal parts, greatly increasing reliability. This also makes it ideal for use with corrosive fluids such as firewater, brackish water or seawater



Stainless Steel



Nickel Aluminium Bronze
(or high alloys)
(for illustration Only)

Features and Benefits

- **3-Way control:** No continuous release from main valve control trim, suitable for foam systems and pit installations
- **Frictionless operation:** Isolating membranes eliminate mechanical friction enhancing safety and reliability, well suited for use with sea-water and corrosive fluids
- **Balanced Poppet Shaft:** Enables a low control pressure, regardless of water line supply pressure
- **Heavy duty construction:** Suitable for on-shore as well as the severe conditions of offshore facilities
- **Corrosion resistant construction materials:** For harsh environments and corrosive media

Technical Data

- **Pressure Rating:** 25 bar / 360psi
- **Minimum Recommended Pilot Line pressure:** 2.5 bar / 36psi
- **Temperature Rating:** 80°C / 180°F
- **Flow Factor:** Kv 1.5 / Cv 1.7
- **Port Connections:** Line pressure ½" NPT Control ¼" NPT
- **Weight:** 1.4kg / 3lbs

Standard Materials

- **Body:** Stainless steel 316, CF8M
- **Wetted Parts:** Stainless steel 316
- **Covers (dry parts):** Stainless steel 316, CF8M
- **Elastomers:** NBR (Buna-N)

* Optional materials: See Model codes and material options on next page

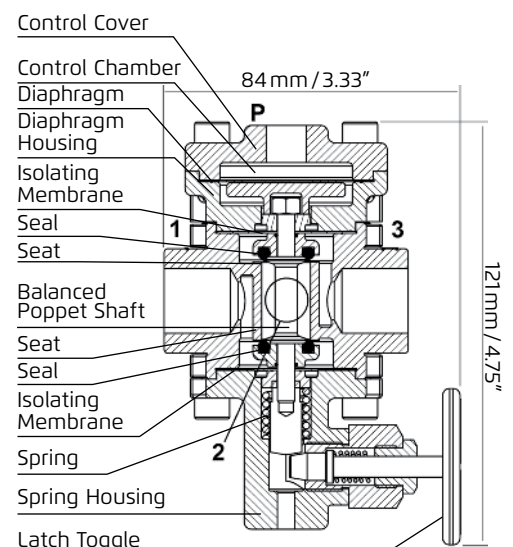



Principle of Operation

The URV utilizes a control chamber and three operational ports.

Actuation or position change is achieved when the relatively low control pressure (air or water) is released from the Control Port (P).

The URV-3-M will latch in this position.

Resetting the URV-3-M to reclose the main valve requires that the latch toggle be pulled whilst simultaneously pressurizing the URV-3-M control chamber

Port 2 is the common port

When the control chamber is depressurized

The passage between ports 2 and 3 is open

The passage between ports 2 and 1 is closed

When the control chamber is pressurized

The passage between ports 2 and 1 is open

The passage between ports 2 and 3 is closed

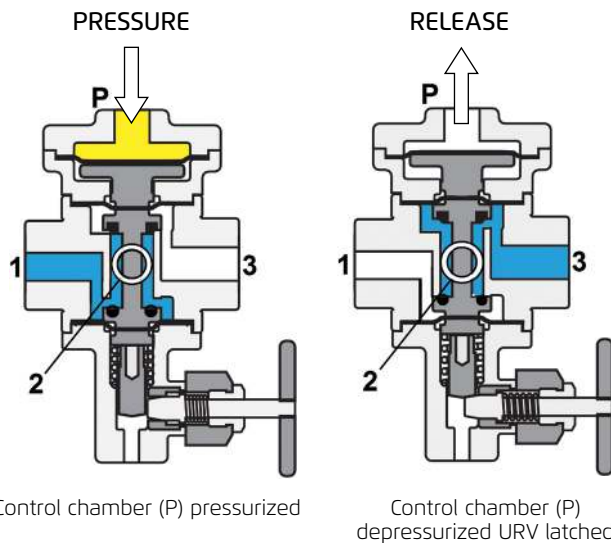

Connections

For the deluge valve to be Normally Open, pressure to close

Connect the supply line pressure to Port 1

Connect the deluge valve control chamber to port 2 (common)

Port 3 will be the vent

Configuration	Function	Port	Symbol
N.C. (pressure to close main valve)	Supply	1	
	Common	2	
	Vent	3	
	Control	P	

Control Pressure Band

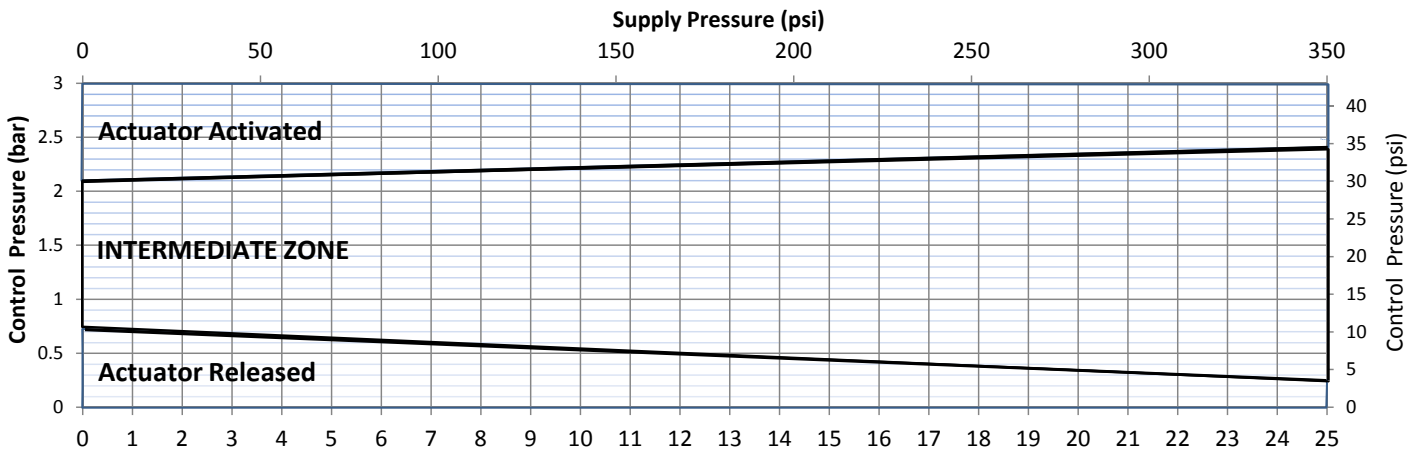

Model Codes and Material Options

Model Code	Body and Wetted Parts	Control Cover	Diaphragm & Spring Housing (dry)
URV-3-M-N-N	Stainless Steel 316	Stainless Steel 316	Stainless Steel 316
URV-3-M-U-N	Ni.Aluminium Bronze (monel shaft)	Stainless Steel 316	
URV-3-M-U-U	Ni.Aluminium Bronze (monel shaft)	Ni.Aluminium Bronze	
URV-3-M-D-N	Super-Duplex	Stainless Steel 316	
URV-3-M-D-D	Super-Duplex	Super-Duplex	

*For other material options/combinations consult BERMAD

