

Quick Pressure Relief Valve

(Sizes 1½-4"; DN40-100)

Description

The Model 73Q Quick Pressure Relief Valve is a hydraulically operated, diaphragm actuated control valve that relieves excessive system pressure that rises above maximum pre-set. It responds immediately, accurately, and with high repeatability by fully opening. The Quick Pressure Relief Valve provides smooth drip tight closing.

Installation

1. Ensure enough space around the valve assembly for future maintenance and adjustments.
2. Prior to valve installation, flush the pipeline to insure flow of clean fluid through the valve.
3. For future maintenance, install Isolation gate valves upstream (and downstream if not releasing to atmosphere) from Bermad control valve.
4. Install the valve in the pipeline with the valve flow direction arrow in the actual flow direction. Use the lifting ring provided on the main valve cover for installing the valve.
5. For best performance, it is recommended to install the valve horizontally and upright.
6. After installation carefully inspect/correct any damaged accessories, piping, tubing, or fittings.

Commissioning & Calibration

1. Confirm that manometer cock valve [38] is open (handle parallel to cock-valve body).
2. Open fully the upstream isolating valve
Note: When upstream pressure is above the 73Q setting, the valve is partially/fully open.
3. Confirm that the supply pressure and the flow through the system are typical.
4. Vent air from the valve's control loop by loosening cover tube fitting at the highest point, allowing all air to bleed. Retighten the tube fitting eyebolt.
5. The Model 73Q is factory set to the maximum system pressure allowed, according to design definitions. The set pressure is marked on the pilot's label.
6. If the set pressure is either different from the design or the requirements have been changed follow the steps described below:
 - 6.1. Confirm that the line pressure is the designed dynamic operating pressure.
Note: When setting is below the designed dynamic operating pressure, the valve is partially/fully open.
 - 6.2. Unlock pilot locking nut & slowly turn the adjusting screw Clock-Wise until the valve close & seal.
 - 6.3. Slowly turn the pilot adjusting screw Counter-Clock-Wise until the valve starts leaking, re-tighten the setting screw until the 73Q seals again plus 1/4 – 1/2 turn and lock the locking nut.
7. The pilot internal restriction enables the 2-Way control & reduces valve closing speed.
8. The 73Q automatically stops closing process, should closing process causes system pressure rise. Thus providing an "ABS" closing characteristics.

Control Drawing

PARTS LIST

4A	In-Line Filter
38	Manometer Cock Valve (w/vent)
30QM	2W Quick Relief Mini Pilot (Metal)

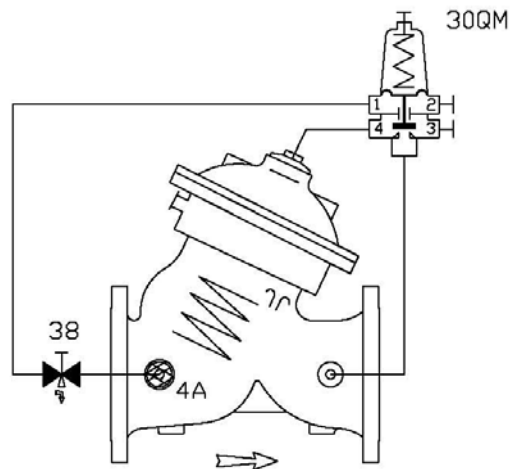

Trouble-Shooting

- Valve fails to Open:** Check for sufficient inlet pressure, confirm pilot setting & check cock valve status.
- Valve fails to Close:** Confirm pilot setting, check cock valve status, clean control filter & detect for clogged ports or fittings, check if any debris trapped in the main valve, confirm diaphragm is not leaking.
- Valve fails to Regulate:** Confirm pilot setting, release air trapped in the control chamber & check cock valve status.

Preventative Maintenance

- System operating conditions that effect on the valve should be checked periodically to determent the required preventative maintenance schedule.
- Maintenance instructions:
 - Tools required:
 - Metric and imperial wrenches
 - Anti seize grease
 - Visual inspection to locate leaks and external damages
 - Functional inspection including: closing, opening and regulation.
 - Close upstream and downstream isolating valves (and external operating pressure when used).
 - Once the valve is fully isolated vent pressure by loosening a plug or a fitting.
 - Open the stud nuts and remove the actuator as one unit from the valve body. Disassemble necessary control tubs.
 - It is highly recommended to stock a reserve actuator assembly for each size. This allows minimum system field work and system down time.
 - Disassemble the actuator and examine its parts carefully for signs of wear, corrosion, or any other abnormal conditions.
 - Replace worn parts and all the Elastomers. Lubricate the bolts and studs threads with Anti seize grease.

Spare parts

Bermad has a convenient and easy to use ordering guide for valve spare-parts and control system components. For solenoid valves refer to model and S/N on solenoid tags.

Pub # : IOMEW73Q-40

By: YE 1/08

Rev: 01YE-1/08

File name: IOMEW73Q-40_01_08

appliceng@bermad.com • www.bermad.com

The information contained in this document is subject to change without notice.

BERMAD shall not be liable for any errors contained herein. All Rights Reserved. © Copyright by BERMAD Control Valves.