

## Closing Speed Control Device

### Model: CSCD

The BERMAD Closing Speed Control Device (CSCD) is a valve control accessory used to adjust the closing speed of BERMAD valves.

The CSCD controls the Main Valve Closing Speed by enabling the adjustment and setting of the water flow rate that is introduced to the BERMAD valve's control chamber upon a closing command. This allows the operator to either decrease or increase the closing speed of the BERMAD main valve.

#### Features

- Field adjustable
- Angled flow, less clogging
- Corrosion Resistant materials as standard
- Tamper proof protective cap
- Compact Design, suitable for deluge valve control trim

#### Typical Applications

- Adjustment of main valve closing speed
- Reduction of main valve back-pressure peaks
- Surge prevention

#### Technical Data

**Pressure Rating:** Maximum: 25 bar/365 psi

**Connections:** Inlet & Outlet ports: ½" NPT (F)

**Temp Rating:** Max. 80°C / 180°F

#### Materials

Body	Control Stem	Protective Cap	Seals
St Steel 316 CF8M	AISI 316	Polycarbonate	NBR
Ni al bronze ASTM B148	Monel 400	Polycarbonate	NBR
Brass ASTM B135M	AISI 316	Polycarbonate	NBR



Stainless Steel



Nickel Aluminum Bronze

(for illustration only)

# BERMAD Fire Protection

Model: CSCD

## Accessories

### Operation

Open the protective cap (1) and loosen the locking nut (3).

Turning the adjusting screw (2) clockwise decreases the flow, lengthening the main valve closing time. Turning the adjusting screw counter-clockwise increases the flow, shortening the closing time of the main valve.

When the desired flow rate has been established, re-tighten the locking nut and replace the tamper proof protective cap.

**Caution:** A CSCD supplied installed on a valve trim is factory adjusted for optimum performance. Any further adjustment may impair the functionality of the main valve.

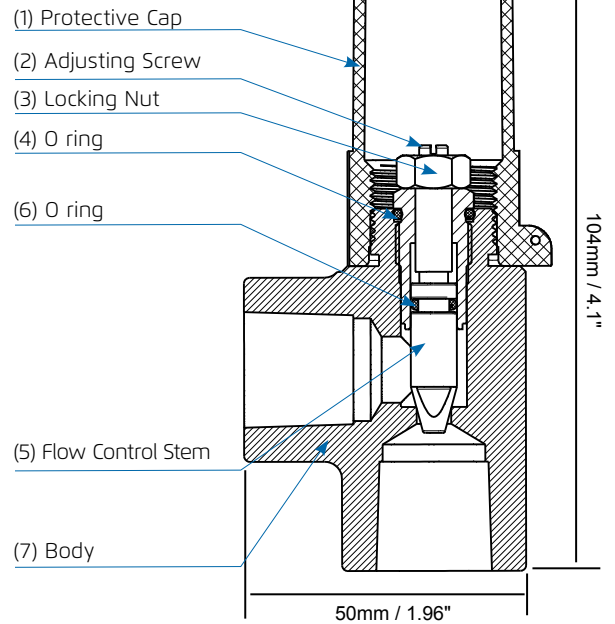

### Flow Coefficient (Kv) Vs. Opening Turns:

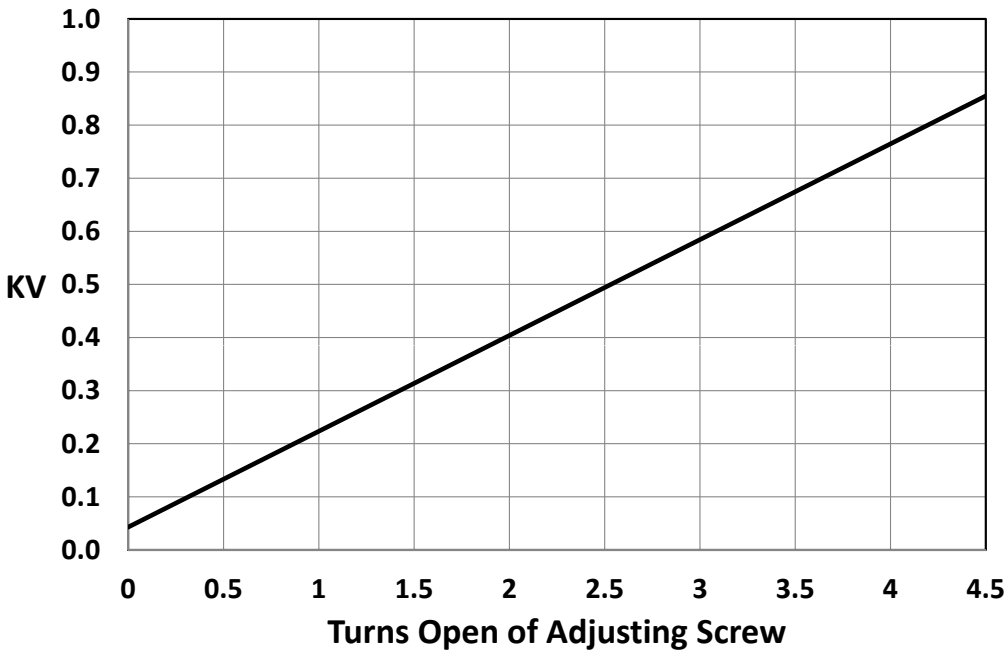

info@bermad.com • www.bermad.com

© Copyright 2007-2012 Bermad CS Ltd. All Rights Reserved. The information contained in this document is subject to change without notice. BERMAD shall not be liable for any errors contained herein. Rev.1 November 2016