

EasyLock™ Manual Reset (EMR)

The BERMAD EasyLock Manual Reset is an automatic Latching device that holds the BERMAD Deluge valve in its open position when the valve has been activated by a releasing device.

The EasyLock blocks the Deluge priming line, preventing Water from entering the valve control chamber and the releasing devices, latching the Deluge valve open. The EasyLock allows the deluge valve to close only upon a local reset, by manually pushing the Reset Knob.

The EasyLock consists of an integrated spring-loaded check valve. A Safety Ball Drip vents any accidental leak to ensure that the Deluge valve remains latched.



(for illustration only)

Features

- Automatically Operated by Line Pressure
- Integral Spring Loaded Check valve
- Safe Design: Elastomeric Moving Parts

Materials

Standard Materials

- Body: Nickel Plated Brass
- Stem: Stainless Steel 316
- Elastomeric Ball: FPM (Viton®)
- Springs: Stainless Steel 302

Stainless Steel Construction

- Body: Stainless Steel 316
- Stem: Stainless Steel 316
- Elastomeric Ball: FPM (Viton®)
- Springs: Stainless Steel 316

NAB Construction

- Body: Ni-Al-Bronze ASTM B148 C95500
- Stem: Monel 400
- Elastomeric Ball: FPM (Viton®)
- Spring: Stainless Steel 316 (dry), Inconel (internal)

Hydraulic Data

- Pressure Rating: 25 bar (365 psi)
- Working Temperature: Water up to 80°C (180°F)
- Flow Factor: Kv 0.46 (Cv 0.54)

Connections

- Inlet: ½" NPT male
- Outlets: ½" NPT female, 3 ports

Set (Stand-by)

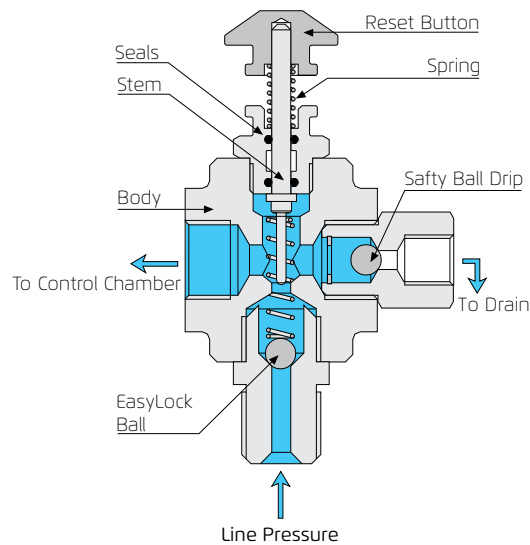

Operation (Latched)

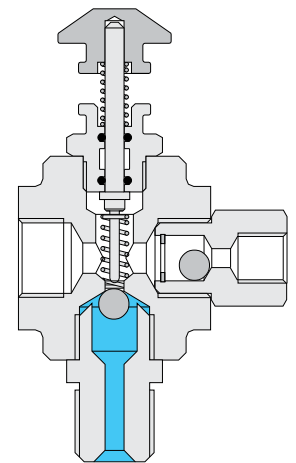

Approvals ⁽¹⁾

- UL Listed
- FM-Approved
- VdS Approved

Care and Maintenance

The BERMAD EasyLock is maintenance free, however a Y Control Strainer with a minimum of 500 micron filter, should be installed upstream of the device in order to prevent residuals from entering the sealing area. The filter element should be cleaned after the first valve operation/start-up and at least quarterly.

Notes:

⁽¹⁾ Approved when installed on BERMAD Deluge Valve with specific trim model