

Exd Pressure Switch

Model PS-HP/RV

The PS-HP/RV is an adjustable Pressure Switch for use with BERMAD Deluge and control valves, to indicate a pre-determined pressure level.

This Pressure Switch offers reliability, repeatability and durability in a compact design. It is suited for operation under the harsh conditions of Zone 1, II 2 G/D Ex d IIC T6 certified for hazardous locations and SIL 2 safety related systems.

At the heart of the PS-HP/RV is a snap action Diaphragm assembly, which transfers motion to one SPDT (Single-Pole Double-Throw) micro-switch.

Suitable for use with water, air or nitrogen pressure sensing in harsh or hazardous environments as in chemical plants, refineries, gas and petroleum installations offshore and marine vessels.

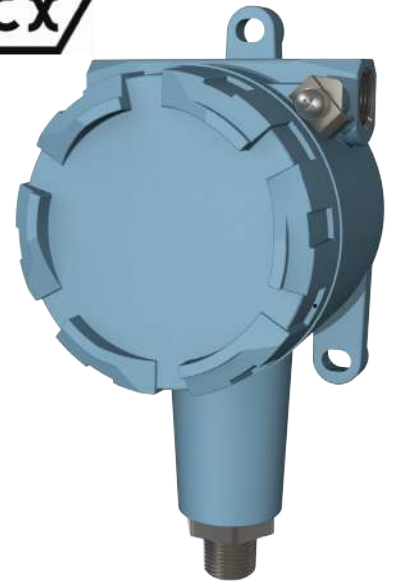

(for illustration only)

Features

- Solid, Single Piece Construction
- Aluminum Epoxy Coated Enclosure - Model PS-HP
- Stainless Steel Enclosure - Model PS-RV
- Pre-Wired Integral Terminal Box
- Safety Vented Design
- Functional Safety Certified as per IEC 61508-2 for use in SIL 2 safety systems
- Convenient Field Adjustable Set-points Against a Reference Scale
- One SPDT (Single-Pole Double-Throw) micro-switch
- Welded Diaphragm
- IP66/NEMA 4x suitable for harsh environments
- NACE MR 01-75 compliant with PS-RVM22SDE02F model

Approvals

- ATEX directive 2014/34/EU II2DG Ex d IIC T6
- CE LVD- Low Voltage Directive 2014/35/EU
- Pressure Equipment Directive (PED) 97/23/EU
- IECEx Certified

Materials

- Wetted parts: Stainless Steel 316 or Monel 400
- Housing: Aluminum Epoxy Coated or Stainless Steel 316
- Diaphragm: Stainless Steel 316 or Monel 400

End Connections

- Pressure (sensor): ½" NPT (M)
- Electric Cable Entry Port: ½" NPT (F)

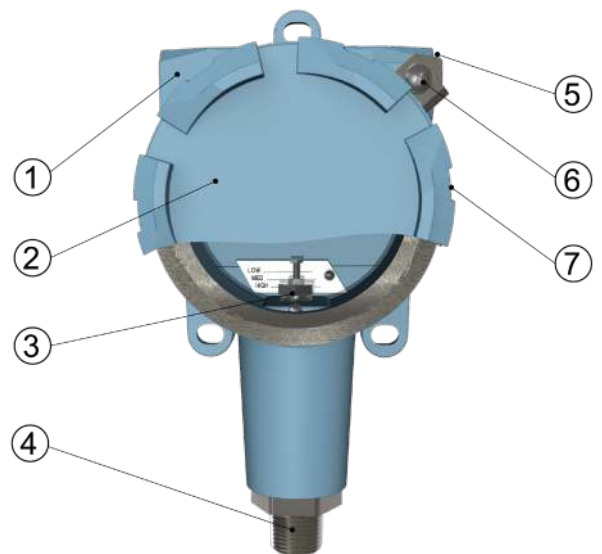

Major Parts

- [1] Switch Housing
- [2] Terminal Box Cover
- [3] Adjustment Screw
- [4] Pressure Connection (sensor)
- [5] Electric Port Connection
- [6] Grounding Screw
- [7] Terminal Box Fixing Screw (HEX 1.5mm)

BERMAD Fire Protection

PS-HP/RV

Indicating Devices

Pressure Setting & Range

- Factory Set: 2.5 bar high, 2.2 bar low
- Adjustable range: 1.0 to 6.0 bar (15 to 85 psi)
- Dead band: 0.23 bar low (3.3 psi)
- Set point repeatability: $\pm 1\%$ of adjustable range
- Max. Working Pressure: 27 bar (390 psi)

Enclosures Class

- ATEX ZONE 1 Classification II 2 G/D Ex d IIC T6 Certified
- IECEx FLAMEPROOF IEC60079-0/1/31
- NEMA 4x / IP66 Weatherproof

Electrical Ratings

- PS-HP: 15A@125/250/480 VAC & 2A@30 VDC
- PS-RV: 5A@110/250 VAC & 2A@30 VDC
- Silver contacts

Ambient Temperature

- Storage and operation: -30°C to $+60^{\circ}\text{C}$ (-22°F to $+140^{\circ}\text{F}$)

Weight

- Aluminum Epoxy Coated Housing: 1.7kg / 3.7lbs
- S.S. 316 Housing: 1.5kg / 3.3lbs

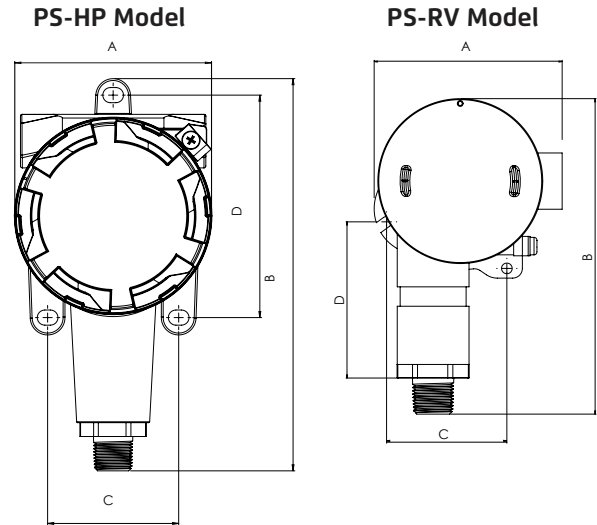

Dim	PS-HP		PS-RV	
	mm	inch	mm	inch
A	107	4.21	97	3.82
B	213	8.39	145	5.71
C	70	2.76	62	2.44
D	120	4.72	78	3.07
Depth	98	3.86	64	2.52

Model Selection Table

Model	Wetted Parts	Enclosure	Sensor
PS-HPG	SS316	Epoxy Coated Aluminum	one SPDT
PS-HPT	Monel 400	Epoxy Coated Aluminum	one SPDT
PS-RVS	SS316	SS316	one SPDT
PS-RVT	Monel 400	SS316	one SPDT

Electrical Wiring:

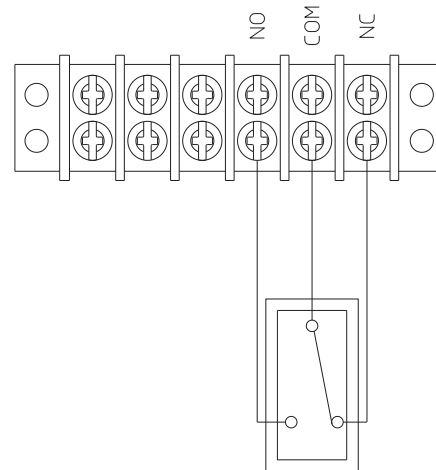

Switch Termination:

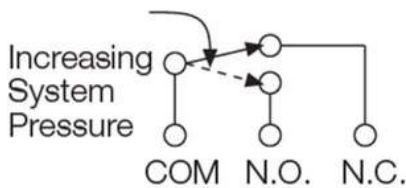

Typical Waterflow Alarm

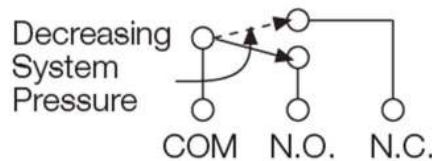

Typical Low Pressure Supervision



info@bermad.com • www.bermad.com

© Copyright 2007-2012 Bermad CS Ltd. All Rights Reserved. The information contained in this document is subject to change without notice. BERMAD shall not be liable for any errors contained herein. March 2017