

IR-400 Basic Valve

The basic Model IR-400 diaphragm actuated hydraulically operated valve is at the leading edge of control valve design. It combines simple and reliable construction with superior performance, while at the same time being virtually free of the typical limitations associated with other single chambered valves. These automatic water control valves are designed for vertical or horizontal installation and are available in diameter sizes of 2-16"; DN50- DN400, in a wide range of materials and end connections.

The design of the IR-400 valve body includes a full bore seat with unobstructed flow path, free of any in-line ribs, supporting cage, or shafts.

The unique hydro-dynamic globe design provides high flow capabilities with minimum head loss. The cover is removable via four (4) fastening bolts (up to 10") for quick in-line inspection and service. The internal design of the IR-400 valve is based on innovative technology using advanced rubber-based materials to achieve a solid, one piece elastomeric assembly including a flexible fabric reinforced diaphragm, vulcanized with a rugged radial seal disk. The diaphragm is carefully balanced and peripherally supported to avoid distortion and to protect the elastomer, resulting in long-life and controlled actuation even under harsh conditions. One diaphragm and spring fully meet the valve's operating pressure range requirements. The diaphragm assembly can be easily removed from the valve body with no need for disassembling the valve from the line.

The Model IR-400 Basic Valve uses valve differential pressure to power the diaphragm assembly open or closed. The lower side of the diaphragm, which serves to cushion the closing of the valve, is exposed to downstream pressure through a dynamic peripheral passageway that its width responds to differential pressure and flow along the downstream side of the valve. The pressure in the control chamber varies, usually resulting from the combined action of a regulating pilot and a fixed orifice. This varying pressure modulates the valve to open or close.



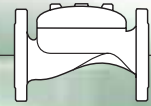

On-Off Modes

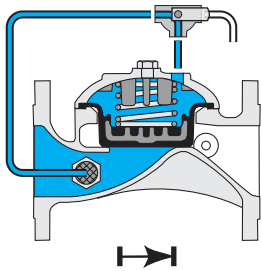

Closed Position

Line pressure applied to the control chamber of the valve creates a hydraulic force that moves the valve to the closed position and provides drip tight sealing.

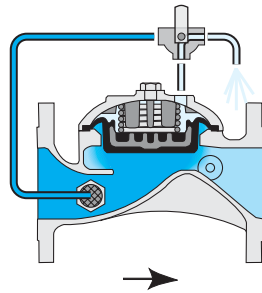

Open Position

Discharging the pressure from the control chamber to atmosphere or some other lower pressure zone, causes the line pressure acting on the plug to open the valve.

2-Way Modulating Modes

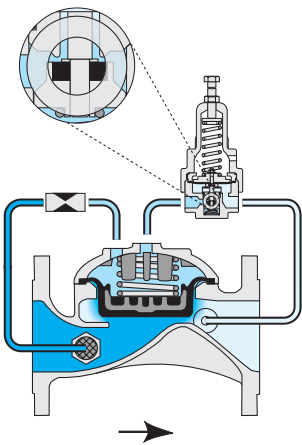

Modulating Closed

The restriction continuously allows line pressure into the control chamber. The pilot controls outflow from the control chamber. Throttling when it senses a pressure rise, it causes pressure to accumulate in the control chamber, thereby forcing the valve to modulate closed.

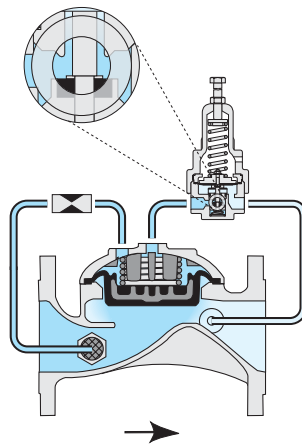

Modulating Open

The pilot modulates open when it senses a pressure drop releasing more flow from the control chamber than the restriction can allow in. This causes the accumulated pressure in the control chamber to drop and the valve modulates open.

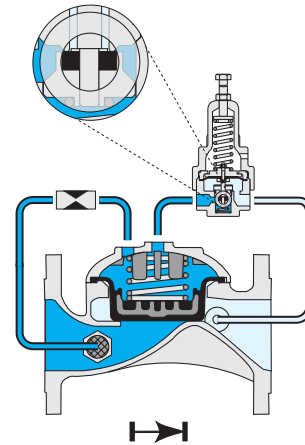

Zero Flow Position

When demand drops to zero, downstream pressure begins to rise as the flow enters a closed line. The pilot closes initiating a valve's irreversible closing process, eventually causing it to seal drip tight.

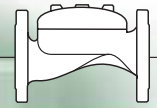

3-Way Control Modes

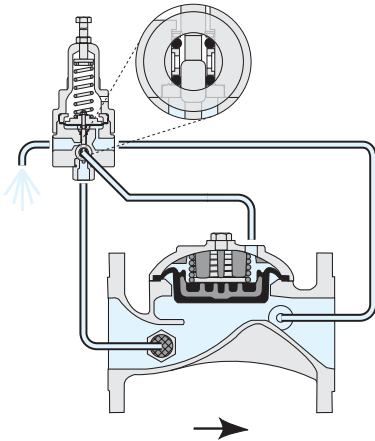

Fully Open Position

When upstream pressure drops, the pilot blocks the pressure port and opens the drain port, venting the control chamber to the atmosphere. This fully opens the valve, minimizing head loss.

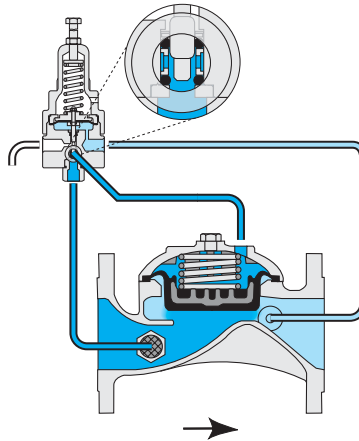

Modulating Closed

The pilot switches upon pressure rise, blocking the drain port and opening the pressure port. This pressurizes the control chamber, forcing the valve to modulate closed.

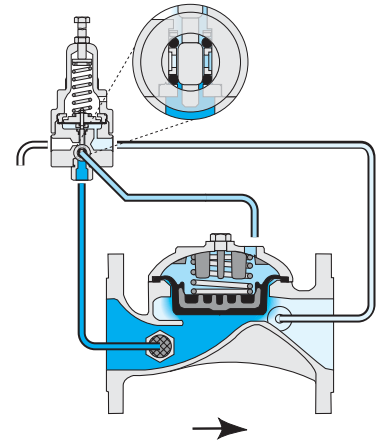

Locked Position

When sensed pressure is equal to setting, the pilot shaft moves and blocks both the drain port and the pressure port. This locks the pressure in the control chamber, freezing the valve in its last position until conditions change.

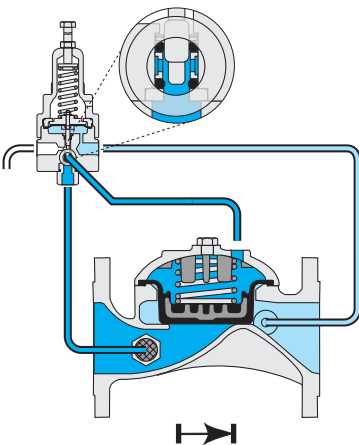

Zero Flow Position

When demand drops to zero, downstream pressure begins to rise as the flow enters a closed line. The pilot switches and pressurizes the control chamber initiating a valve's irreversible closing process, eventually causing it to seal drip tight.

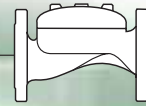

[1] **Fastening Bolts**

Only four bolts (up to 10"; DN250 valve) fasten valve cover to body, ensuring quick in-line inspection and service.

[2] **Valve Cover**

Locates, centralizes and fastens diaphragm and spring ensuring smooth and accurate performance. Simple construction enables quick in-line inspection and service.

[3] **Auxiliary Closing Spring**

One single spring fully meets valve requirements for operating pressure range, ensuring low opening pressure and secured closing.

[4] **Diaphragm Assembly**

One piece elastomeric assembly that includes a peripherally supported flexible diaphragm, vulcanized with a rugged radial seal disk.

- No need for special types of diaphragms to meet different operating conditions.
- Progressive dynamic guidance, resulting in exceptionally stable action and restrained closing.
- Valve opens and closes drip tight even with very low pressure supply.
- Perfectly balanced diaphragm with no distortion caused by uneven hydraulic forces on shut-off or during regulation.
- Exceptionally stable and chatter-free action during shut-off and pressure regulation.

[5] **Body Threads**

No need for nuts, simplifying valve disassembling and assembling for maintenance.

[6] **Wide Body Valve**

Hydro-dynamically designed for efficient flow with minimal pressure loss and excellent resistance to cavitation.

[6.1] Diaphragm Supporting & Guiding

[6.2] Diaphragm Balancing Chamber

[6.3] Valve Seat: Full bore, valve port area clear of obstructions; no ribs or stem guides. Flow entrance is vertical to seal disk.

[6.4] End Connections: Conforms to pressure ratings and standards of: ISO, ANSI, JIS, BS, and others.

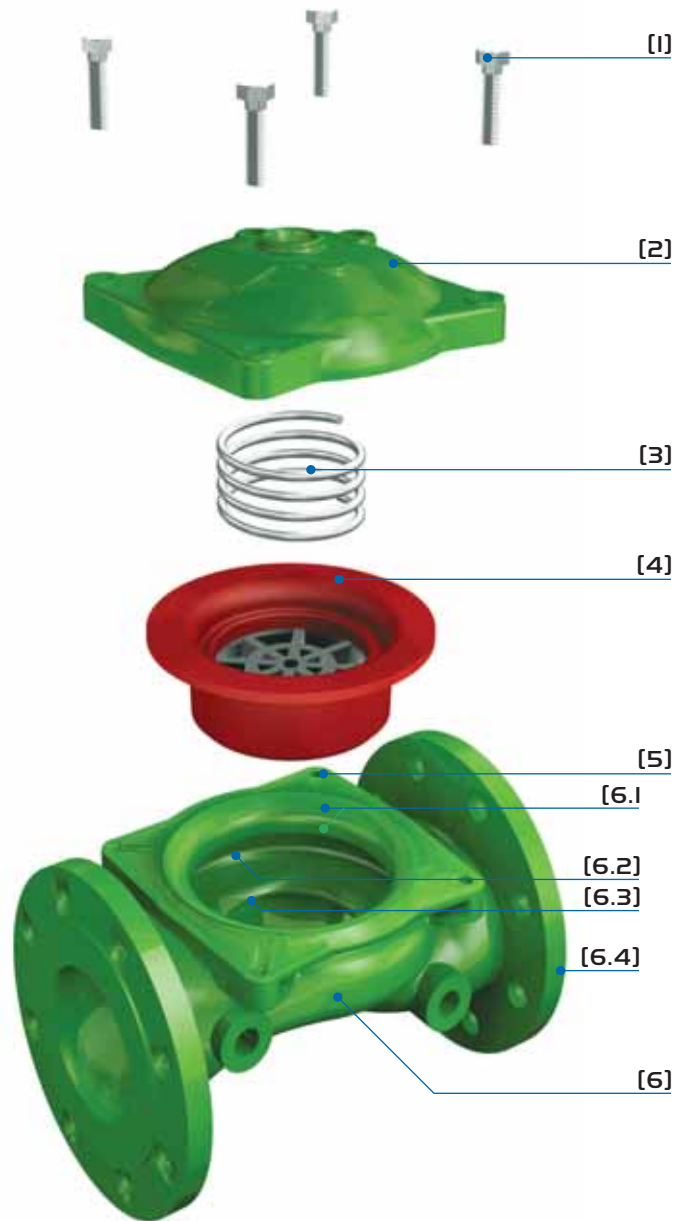

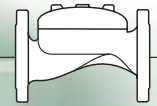

Construction Materials

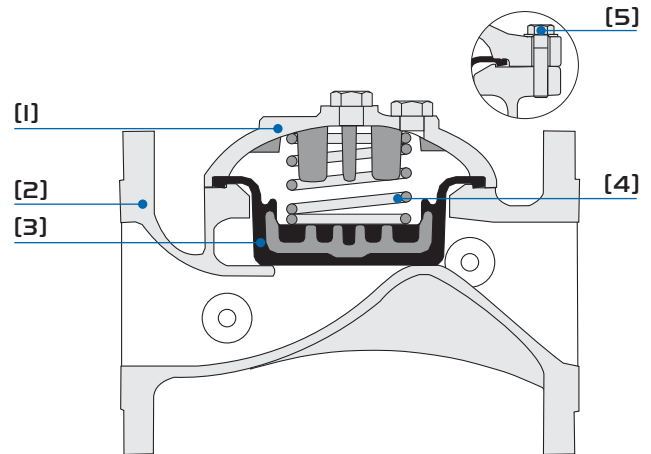

| Description | GR-400 | | IR-400 | | |
|------------------------|-------------------------------------|-------------------------------------|-------------------------------------|--------------|-------------------------------------|
| | DN20-50 | DN40-150 | DN200 | DN250-400 | DN50-100 |
| Pattern | Globe | Globe | Globe | Globe | Angle |
| Cover [1] | Brass | Cast Iron | Cast Iron | Ductile Iron | Cast Iron |
| Valve Body [2] | Brass | Cast Iron ⁽¹⁾ | Cast Iron ⁽¹⁾ | Ductile Iron | Cast Iron |
| Diaphragm Assembly [3] | NR with Plastic VRSD ⁽²⁾ | NR with Plastic VRSD ⁽²⁾ | NR with Plastic VRSD ⁽²⁾ | | NR with Plastic VRSD ⁽²⁾ |
| Spring [4] | St. St. 302 | | Stainless Steel 302 302 | | |
| External Bolts [5] | St. St. 304 | | Zinc-Cobalt Plated Steel | | |
| Coating | Un-Coated | | Polyester Green RAL 6017 | | |
| Pressure Rating | PN10 | | PN16 | | |

(1) DN100 & 150 grooved valves are constructed of Ductile Iron
 (2) Vulcanized Radial Seal Disk

Technical Specifications

Available Patterns, Size & End Connections

| Connections | GR-400 | | | | IR-400 | | | |
|-------------|--------|------|------|------|--------|-------|-------|-------|
| | DN20 | DN25 | DN40 | DN50 | DN40 | DN50 | DN65 | DN80R |
| Threaded | G | G | G | G | G | G & A | G & A | G & A |
| Flanged | | | | | | G & A | G | G |
| Grooved | | | | | | G | | |

| Connections | IR-400 | | | | | | | |
|-------------|--------|-------|-------|-------|-------|-------|-------|-------|
| | DN80 | DN100 | DN150 | DN200 | DN250 | DN300 | DN350 | DN400 |
| Threaded | G & A | | | | | | | |
| Flanged | G & A | G & A | G | G | G | G | G | G |
| Grooved | G & A | G & A | G | | | | | |

G = Globe, A = Angle

Connections Standard:

Flanged: ISO 7005-2 (PN10 & 16)
 Threaded: Rp ISO 7/1 (BSP.P) or NPT
 Grooved: ANSI C606

Operating Pressure Ranges:

IR-400: 0.5-16 bar
 For lower pressure requirements, consult factory
 GR-400: 0.5-10 bar

Temperature: Water up to 60°C

Standard Materials:

- Castings & Forgings:
 - Cast Iron to EN 1561
 - Ductile Iron to EN 1563
 - Brass
 - Plasti: Polyamid 6+30% GF
- Elastomers: NR to EN 681-1
- Coatings: Electrostatic Powder Coating Polyester



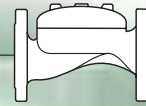

Globe Pattern

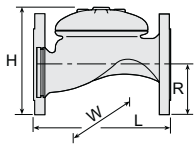

| Size | Flanged | | | | | | | | | | |
|-------------|---------|------|-------|------|-------|-------|-------|-------|-------|-------|-------|
| | DN50 | DN65 | DN80R | DN80 | DN100 | DN150 | DN200 | DN250 | DN300 | DN350 | DN400 |
| L (mm) | 205 | 205 | 210 | 250 | 320 | 415 | 500 | 605 | 725 | 742 | 742 |
| H (mm) | 155 | 178 | 200 | 210 | 242 | 345 | 430 | 460 | 635 | 655 | 965 |
| W (mm) | 155 | 178 | 200 | 200 | 223 | 306 | 365 | 405 | 580 | 587 | 600 |
| R (mm) | 78 | 89 | 100 | 100 | 112 | 140 | 170 | 202 | 242 | 260 | 300 |
| Weight (kg) | 9 | 10.5 | 12.1 | 19 | 28 | 68 | 125 | 140 | 290 | 358 | 377 |

| Size | Threaded | | | | | Grooved | | | |
|-------------|----------|------|------|-------|------|---------|------|-------|-------|
| | DN40 | DN50 | DN65 | DN80R | DN80 | DN50 | DN80 | DN100 | DN150 |
| L (mm) | 153 | 180 | 210 | 210 | 255 | 205 | 250 | 320 | 415 |
| H (mm) | 87 | 114 | 132 | 140 | 165 | 108 | 155 | 191 | 302 |
| W (mm) | 98 | 119 | 129 | 129 | 170 | 119 | 170 | 204 | 306 |
| R (mm) | 29 | 39 | 45 | 53 | 55 | 31 | 46 | 61 | 85 |
| Weight (kg) | 2 | 4 | 5.7 | 5.8 | 13 | 5 | 10.6 | 16.2 | 49 |

Angle Pattern

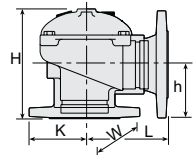

| Size | Threaded | | | | Grooved | | Flanged | | |
|-------------|----------|------|-------|------|---------|-------|---------|------|-------|
| | DN50 | DN65 | DN80R | DN80 | DN80 | DN100 | DN50 | DN80 | DN100 |
| L (mm) | 86 | 110 | 110 | 110 | 120 | 160 | 121 | 153 | 160 |
| H (mm) | 136 | 180 | 178 | 184 | 194 | 223 | 160 | 205 | 223 |
| W (mm) | 119 | 131 | 131 | 170 | 170 | 204 | 155 | 200 | 223 |
| h (mm) | 61 | 93 | 91 | 80 | 90 | 112 | 83 | 101 | 112 |
| K (mm) | 56 | 66 | 66 | 55 | 45 | 58 | 78 | 100 | 112 |
| Weight (kg) | 4.4 | 5.8 | 7 | 11 | 10 | 16 | 9 | 17 | 26 |

Globe Pattern GR-400

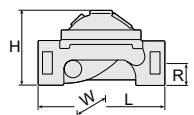

| Size | DN20 | DN25 | DN40 | DN50 |
|-------------|------|------|------|------|
| L (mm) | 112 | 115 | 150 | 180 |
| H (mm) | 68 | 70 | 89 | 103 |
| W (mm) | 22 | 23 | 32 | 39 |
| R (mm) | 72 | 72 | 94 | 118 |
| Weight (kg) | 0.95 | 0.95 | 1.5 | 4 |

Control Chamber Displacement Volume (liter)

| DN50 | DN65 | DN80 | DN100 | DN150 | DN200 | DN250 | DN300-400 |
|-------|-------|-------|-------|-------|-------|-------|-----------|
| 0.113 | 0.179 | 0.291 | 0.668 | 1.973 | 3.858 | 3.858 | 13.75 |

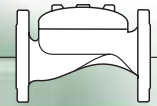

SI Metric

Globe Pattern

2-Way circuit "Added Head Loss"
(for "V" below 2 m/s): 0.3 bar

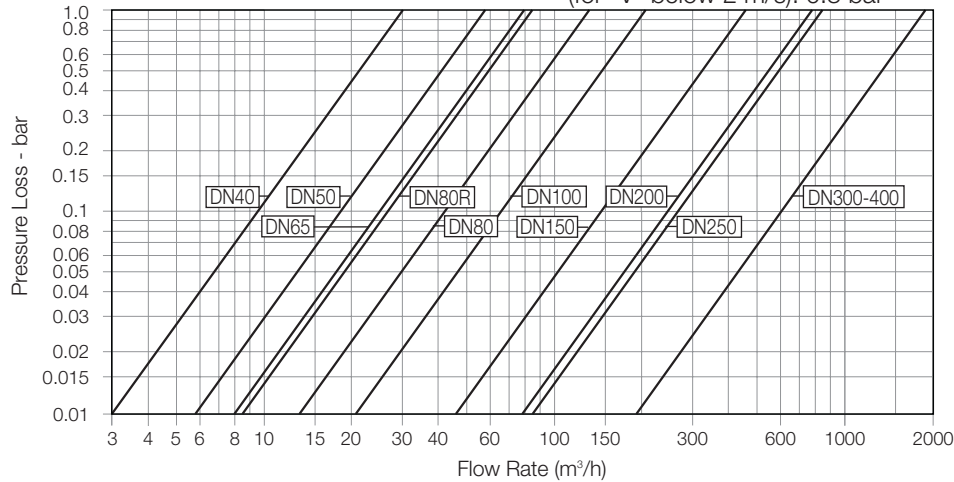

Angle Pattern

2-Way circuit "Added Head Loss"
(for "V" below 2 m/s): 0.3 bar

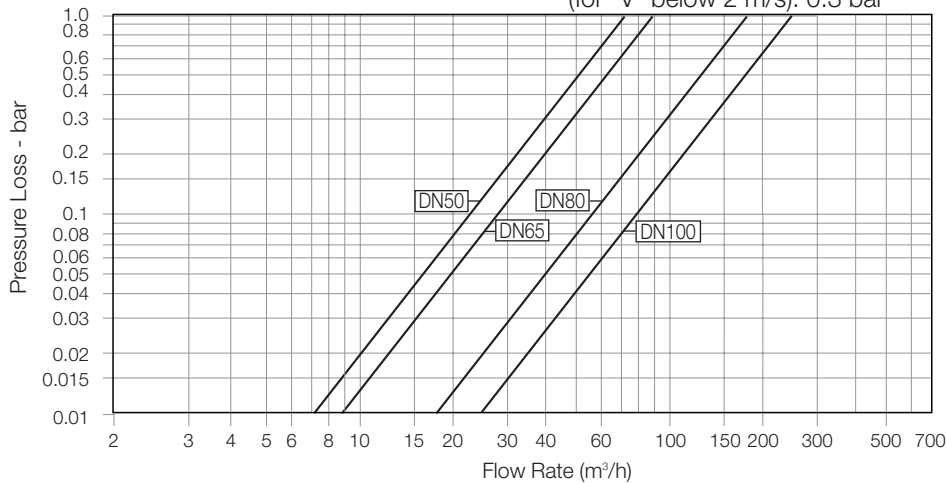

Globe Pattern GR-400

2-Way circuit "Added Head Loss"
(for "V" below 2 m/s): 0.3 bar

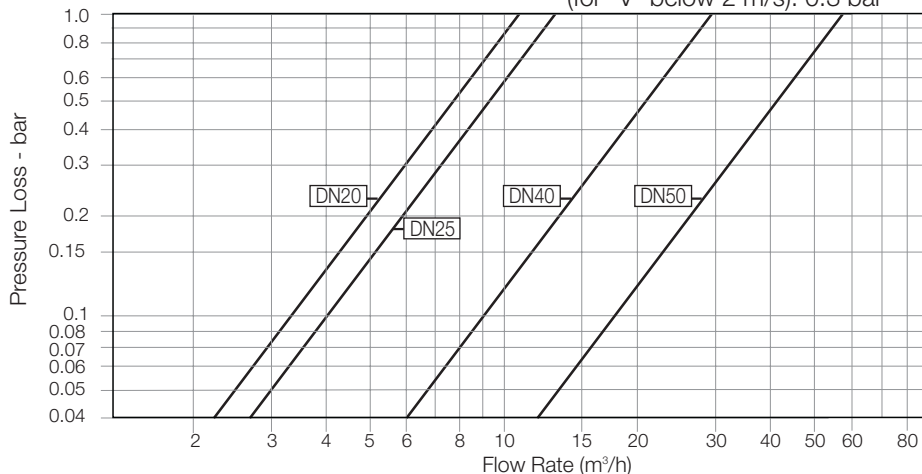

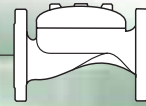

SI Metric

| | | Size | DN50 | DN65 | DN80 | DN100 | DN150 | DN200 | DN250 | DN300-400 |
|------------------|--|---------|------|------|------|-------|-------|-------|-------|-----------|
| Globe Pattern | | Kv | 57 | 78 | 136 | 204 | 458 | 781 | 829 | 1,932 |
| | | K | 3.2 | 4.2 | 2.9 | 4.0 | 4.0 | 4.4 | 3.9 | 3.6 |
| | | Leq - m | 9.1 | 12.1 | 13.7 | 14 | 27.4 | 45.8 | 108 | 57 |

Valve flow coefficient, Kv or Cv

$$Kv(Cv) = Q \sqrt{\frac{Gf}{\Delta P}}$$

Where:

Kv = Valve flow coefficient (flow in m³/h at 1bar Diff. Press.)

Cv = Valve flow coefficient (flow in gpm at Diff. Press. 1psi)

Q = Flow rate (m³/h ; gpm)

ΔP = Differential pressure (bar ; psi)

Gf = Liquid specific gravity (Water = 1.0)

$$Cv = 1.155 Kv$$

Equivalent Pipe Length, Leq

$$Leq = Lk \cdot D$$

Where:

Leq = Equivalent nominal pipe length (m ; feet)

Lk = Equivalent length coefficient for turbulent flow in clean commercial steel pipe (SCH 40)

D = Nominal pipe diameter (m ; feet)

Note:

The Leq values given are for general consideration only.

Flow resistance or Head loss coefficient,

$$K = \Delta H \frac{2g}{V^2}$$

Where:

K = Flow resistance or Head loss coefficient (dimensionless)

ΔH = Head loss (m ; feet)

V = Nominal size flow velocity (m/sec ; feet/sec.)

g = Acceleration of gravity (9.81 m/sec² ; 32.18 feet/sec²)

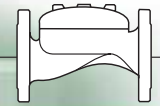

Construction Materials

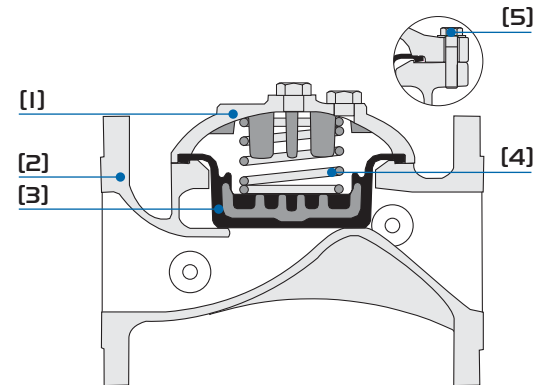

| Description | GR-400 | | GR-400 | | | |
|------------------------|-------------------------------------|-------------------------------------|---------------------------------------|--------------|-------------------------------------|--|
| | 3/4-3" | 1 1/2-6" | 8" | 10-16" | 2-4" | |
| Pattern | Globe | Globe | Globe | Globe | Angle | |
| Cover [1] | Brass | Cast Iron | Cast Iron | Ductile Iron | Cast Iron | |
| Valve Body [2] | Brass | Cast Iron ⁽¹⁾ | Cast Iron ⁽¹⁾ | Ductile Iron | Cast Iron | |
| Diaphragm Assembly [3] | NR with Plastic VRSD ⁽²⁾ | NR with Plastic VRSD ⁽²⁾ | NR with Cast Iron VRSD ⁽²⁾ | | NR with Plastic VRSD ⁽²⁾ | |
| Spring [4] | St. St. 302 | Stainless Steel 302 | | | | |
| External Bolts [5] | St. St. 304 | Zinc-Cobalt Plated Steel | | | | |
| Coating | Un-Coated | Polyester Green RAL 6017 | | | | |
| Pressure Rating | 150 psi | 230 psi | | | | |

(1) 4 & 6" grooved valves are constructed of Ductile Iron
 (2) Vulcanized Radial Seal Disk

Technical Specifications

Available Patterns, Size & End Connections

| Connections | GR-400 | | | | IR-400 | | | |
|-------------|--------|----|--------|----|--------|-------|--------|-------|
| | 3/4" | 1" | 1 1/2" | 2" | 1 1/2" | 2" | 2 1/2" | 3"R |
| Threaded | G | G | G | G | G | G & A | G & A | G & A |
| Flanged | | | | | | G & A | G | G |
| Grooved | | | | | | G | | |

| Connections | IR-400 | | | | | | | |
|-------------|--------|-------|----|----|-----|-----|-----|-----|
| | 3" | 4" | 6" | 8" | 10" | 12" | 14" | 16" |
| Threaded | G & A | | | | | | | |
| Flanged | G & A | G & A | G | G | G | G | G | G |
| Grooved | G & A | G & A | G | | | | | |

G = Globe, A = Angle

Connections Standard:

Flanged:

- ANSI B16.42 (Cast Iron)
- ANSI B16.42 (Ductile Iron)

Threaded: NPT or Rp ISO 7/1 (BSP.P)

Grooved: ANSI C606

Operating Pressure Ranges:

IR-400: 7-232 psi

For lower pressure requirements, consult factory

GR-400: 7-150 psi

Temperature: Water up to 140°F

Standard Materials:

- Castings & Forgings:
 - Cast Iron to ASTM A-126 Class B
 - Ductile Iron to ASTM A-536
 - Brass
 - Plastic: Polyamid 6+30% GF
- Elastomers: NR to ASTM-D-2000
- Coatings: Electrostatic Powder Coating Polyester



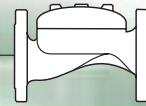

Globe Pattern

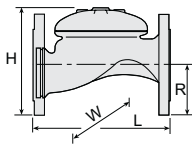

| Size | Flanged | | | | | | | | | | |
|-------------|--------------------------------|--------------------------------|---------------------------------|---------------------------------|--------------------------------|---------------------------------|----------------------------------|----------------------------------|---------------------------------|----------------------------------|----------------------------------|
| | 2" | 2 1/2" | 3"R | 3" | 4" | 6" | 8" | 10" | 12" | 14" | 16" |
| L (inch) | 8 ¹ / ₁₆ | 8 ¹ / ₁₆ | 8 ¹ / ₄ | 9 ¹³ / ₁₆ | 12 ⁵ / ₈ | 16 ⁵ / ₁₆ | 19 ¹¹ / ₁₆ | 23 ¹³ / ₁₆ | 28 ⁹ / ₁₆ | 29 ¹ / ₄ | 29 ¹ / ₄ |
| H (inch) | 6 ¹ / ₈ | 7 | 7 ⁷ / ₈ | 8 ¹ / ₄ | 9 ¹ / ₂ | 13 ⁹ / ₁₆ | 16 ¹⁵ / ₁₆ | 18 ¹ / ₈ | 25 | 25 ¹³ / ₁₆ | 38 |
| W (inch) | 6 ¹ / ₈ | 7 | 7 ⁷ / ₈ | 7 ⁷ / ₈ | 8 ³ / ₄ | 12 | 14 ³ / ₈ | 15 ¹⁵ / ₁₆ | 22 ⁷ / ₈ | 23 ¹ / ₈ | 23 ⁵ / ₈ |
| R (inch) | 3 ¹ / ₁₆ | 3 ¹ / ₂ | 3 ¹⁵ / ₁₆ | 3 ¹⁵ / ₁₆ | 4 ¹ / ₂ | 5 ¹ / ₂ | 6 ¹¹ / ₁₆ | 7 ¹⁵ / ₁₆ | 9 ¹ / ₂ | 10 ¹ / ₄ | 11 ¹³ / ₁₆ |
| Weight (lb) | 19.8 | 23.1 | 41.9 | 41.9 | 61.7 | 149.9 | 275.6 | 308.6 | 639.3 | 789.2 | 831.1 |

| Size | Threaded | | | | | Grooved | | | |
|-------------|-------------------------------|---------------------------------|---------------------------------|--------------------------------|---------------------------------|---------------------------------|---------------------------------|--------------------------------|---------------------------------|
| | 1 1/2" | 2" | 2 1/2" | 3"R | 3" | 2" | 3" | 4" | 6" |
| L (inch) | 6 | 7 ¹ / ₁₆ | 8 ¹ / ₄ | 8 ¹ / ₄ | 10 | 8 ¹ / ₁₆ | 9 ¹³ / ₁₆ | 12 ⁵ / ₈ | 16 ⁵ / ₁₆ |
| H (inch) | 3 ³ / ₈ | 4 ¹⁶ / ₁₆ | 5 ³ / ₁₆ | 5 ¹ / ₂ | 6 ¹ / ₂ | 4 ¹ / ₄ | 6 ¹ / ₁₆ | 7 ¹ / ₂ | 15 ⁷ / ₈ |
| W (inch) | 3 ⁷ / ₈ | 4 ¹¹ / ₁₆ | 5 ¹ / ₁₆ | 5 ¹ / ₁₆ | 6 ¹¹ / ₁₆ | 4 ¹¹ / ₁₆ | 6 ¹¹ / ₁₆ | 8 | 12 ¹ / ₁₆ |
| R (inch) | 1 ¹ / ₈ | 1 ¹ / ₂ | 1 ¹³ / ₁₆ | 2 ¹ / ₁₆ | 2 ³ / ₁₆ | 1 ³ / ₁₆ | 1 ⁶ / ₈ | 2 ³ / ₈ | 3 ³ / ₈ |
| Weight (lb) | 4.4 | 8.8 | 12.6 | 12.8 | 28.7 | 11.0 | 23.4 | 35.7 | 108.0 |

Angle Pattern

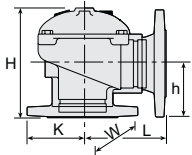

| Size | Threaded | | | | Grooved | | Flanged | | |
|-------------|---------------------------------|---------------------------------|--------------------------------|---------------------------------|---------------------------------|--------------------------------|--------------------------------|---------------------------------|--------------------------------|
| | 2" | 2 1/2" | 3"R | 3" | 3" | 4" | 2" | 3" | 4" |
| L (inch) | 3 ³ / ₈ | 4 ⁵ / ₁₆ | 4 ⁵ / ₁₆ | 4 ³ / ₈ | 4 ³ / ₄ | 6 ⁵ / ₁₆ | 4 ³ / ₄ | 6 | 6 ¹ / ₄ |
| H (inch) | 5 ³ / ₈ | 7 ¹ / ₁₆ | 7 | 7 ¹ / ₄ | 7 ⁵ / ₈ | 8 ³ / ₄ | 6 ⁵ / ₁₆ | 8 ¹ / ₁₆ | 8 ³ / ₄ |
| W (inch) | 4 ¹¹ / ₁₆ | 5 ³ / ₁₆ | 5 ³ / ₁₆ | 6 ¹¹ / ₁₆ | 6 ¹¹ / ₁₆ | 8 | 6 ¹ / ₈ | 7 ⁷ / ₈ | 8 ³ / ₄ |
| h (inch) | 2 ³ / ₈ | 3 ¹¹ / ₁₆ | 3 ⁹ / ₁₆ | 3 ¹ / ₈ | 3 ⁹ / ₁₆ | 4 ¹ / ₂ | 3 ¹ / ₄ | 4 | 4 ⁷ / ₁₆ |
| K (inch) | 2 ³ / ₁₆ | 2 ⁵ / ₈ | 2 ⁵ / ₈ | 2 ³ / ₁₆ | 1 ³ / ₄ | 2 ⁵ / ₁₆ | 3 ¹ / ₁₆ | 3 ¹⁵ / ₁₆ | 4 ⁷ / ₁₆ |
| Weight (lb) | 9.7 | 12.8 | 15.4 | 24.3 | 22.0 | 35.3 | 19.8 | 37.5 | 57.3 |

Globe Pattern GR-400

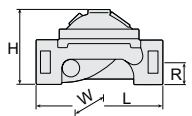

| Size | 3/4" | 1" | 1 1/2" | 2" |
|-------------|---------------------------------|---------------------------------|---------------------------------|--------------------------------|
| L (inch) | 4 ⁷ / ₁₆ | 4 ¹ / ₂ | 5 ⁷ / ₈ | 7 ¹ / ₈ |
| H (inch) | 2 ¹¹ / ₁₆ | 2 ³ / ₄ | 3 ¹ / ₂ | 4 ¹ / ₁₆ |
| W (inch) | 7/8 | 1 ⁵ / ₁₆ | 1 ¹ / ₄ | 1 ⁹ / ₁₆ |
| R (inch) | 2 ¹³ / ₁₆ | 2 ¹³ / ₁₆ | 3 ¹¹ / ₁₆ | 4 ⁵ / ₈ |
| Weight (lb) | 2.1 | 2.1 | 3.3 | 8.8 |

Control Chamber Displacement Volume (gallons)

| 2" | 2 1/2" | 3" | 4" | 6" | 8 | 10" | 12-16" |
|------|--------|------|------|------|------|------|--------|
| 0.03 | 0.05 | 0.08 | 0.18 | 0.52 | 1.02 | 1.02 | 3.63 |



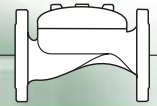

Globe Pattern

2-Way circuit "Added Head Loss"
(for "V" below 6.5 f/s): 4.5 psi

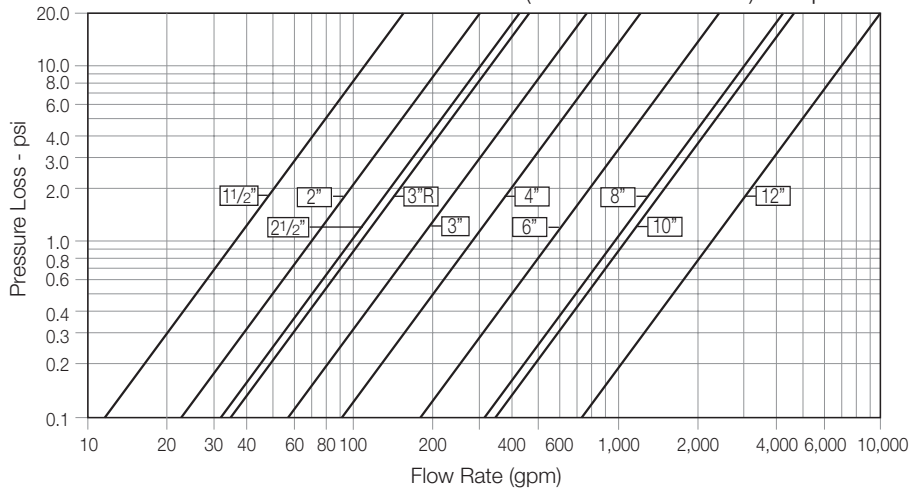

Angle Pattern

2-Way circuit "Added Head Loss"
(for "V" below 6.5 f/s): 4.5 psi

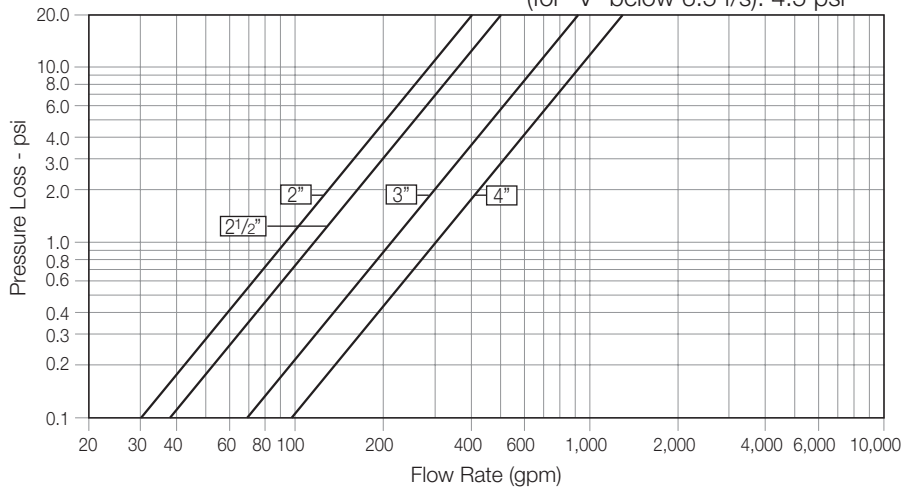

Globe Pattern GR-400

2-Way circuit "Added Head Loss"
(for "V" below 6.5 f/s): 4.5 psi

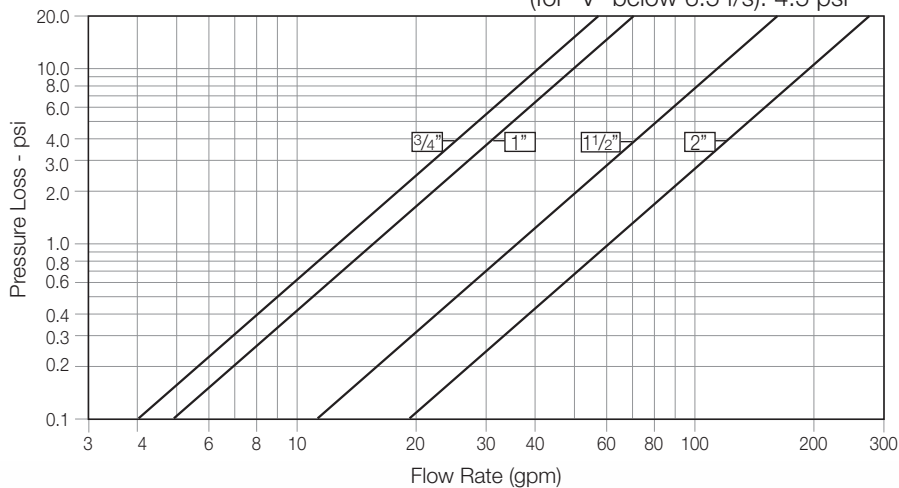

BERMAD Irrigation

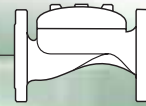

Flow Properties

400 Series

US English

| | | | 2" | 2 1/2" | 3" | 4" | 6" | 8" | 10" | 12-16" |
|------------------|--|----------|-----|--------|-----|-----|-----|-----|-----|--------|
| Globe Pattern | | Cv | 66 | 90 | 157 | 236 | 529 | 902 | 957 | 2,231 |
| | | K | 3.2 | 4.2 | 2.9 | 4.0 | 4.0 | 4.4 | 3.9 | 3.6 |
| | | Leq - ft | 30 | 40 | 45 | 46 | 90 | 150 | 354 | 187 |

Valve flow coefficient, Kv or Cv

$$Kv(Cv) = Q \sqrt{\frac{Gf}{\Delta P}}$$

Where:

Kv = Valve flow coefficient (flow in m³/h at 1bar Diff. Press.)

Cv = Valve flow coefficient (flow in gpm at Diff. Press. 1psi)

Q = Flow rate (m³/h ; gpm)

ΔP = Differential pressure (bar ; psi)

Gf = Liquid specific gravity (Water = 1.0)

$$Cv = 1.155 Kv$$

Equivalent Pipe Length, Leq

$$Leq = Lk \cdot D$$

Where:

Leq = Equivalent nominal pipe length (m ; feet)

Lk = Equivalent length coefficient for turbulent flow in clean commercial steel pipe (SCH 40)

D = Nominal pipe diameter (m ; feet)

Note:

The Leq values given are for general consideration only.

Flow resistance or Head loss coefficient,

$$K = \Delta H \frac{2g}{V^2}$$

Where:

K = Flow resistance or Head loss coefficient (dimensionless)

ΔH = Head loss (m ; feet)

V = Nominal size flow velocity (m/sec ; feet/sec.)

g = Acceleration of gravity (9.81 m/sec² ; 32.18 feet/sec²)