



URV (Universal Relay Valve)

Model URV-2-0

The BERMAD URV-2-0 is a Normally Open 2-Way Spring return, balanced poppet type, pressure operated, and diaphragm actuated pilot valve. The URV changes its position from open to close in response to pressure being supplied to its control chamber.

The URV pilot valve is used as a relay device designed for use with BERMAD Deluge and Remote Control Monitor Valves. Its function is to actuate the BERMAD main valve upon pressure release (pressure to close).

The URV's balanced-poppet design enables safe reliable operation with a low control pressure whilst using compact dimensions. The URV is specifically designed for Fire Safety systems in that it has no mechanical friction of the internal parts, greatly increasing reliability. This also makes it ideal for use with corrosive fluids such as firewater, brackish water or seawater.



Stainless Steel



Nickel Aluminium Bronze
(for Illustration Only)

Features and Benefits

- **Frictionless operation:** Isolating membrane increases safety and reliability, well suited for use with sea-water and corrosive fluids
- **Balanced Poppet Shaft:** Enables a low control/pilot pressure regardless of the line supply pressure
- **Heavy duty construction:** Suitable for the harsh conditions of chemical and offshore facilities
- **Corrosion resistant construction materials**

Technical Data

- **Pressure Rating:** 25 bar / 360 psi
- **Minimum Recommended Pilot Line Pressure:** 1.7 bar / 24.2 psi
- **Temperature Rating:** 80°C / 180°F
- **Flow Factor:** Kv 1.5 / Cv 1.7
- **Port Connections:** Line pressure ½" NPT Control ¼" NPT
- **Weight:** 1.1kg / 2.4 lbs

Standard Materials

- **Body:** Stainless Steel 316, CF8M
- **Wetted Parts:** Stainless Steel 316
- **Covers (dry parts):** Stainless Steel 316, CF8M
- **Elastomers:** NBR (Buna-N)
- **Bolts:** Stainless Steel 316
- **Spring:** Stainless Steel 316

*Optional materials: See Model codes and Material options on next page

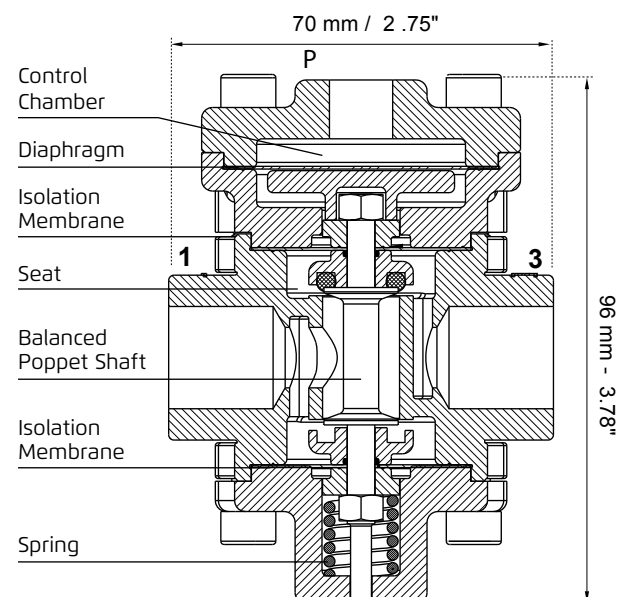



Operation

The URV-2-0 utilizes a control chamber and three operational ports.

Actuation or position change is achieved by applying a relatively low control pressure (air or water) to the Control Port (P)

Flow through the URV can be "Straight"
From port 1 to port 3 or "Angular" at 90°
From port 2 to port 3

(See connections table below)

Connections

Connecting supply pressure to port 1 enables a straight flow to the outlet port 3.

Connecting supply pressure to port 2 enables a 90° angle flow to the outlet port 3.

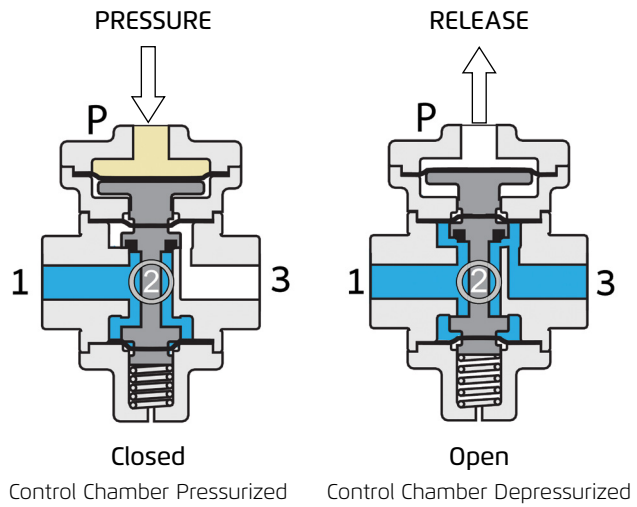

Configuration	Function	Port	Symbol
Straight Flow	Supply	1	
	Outlet	3	
	Control	P	
Angle Flow	Supply	2	
	Outlet	3	
	Control	P	

Control / Pilot Line Pressure Chart

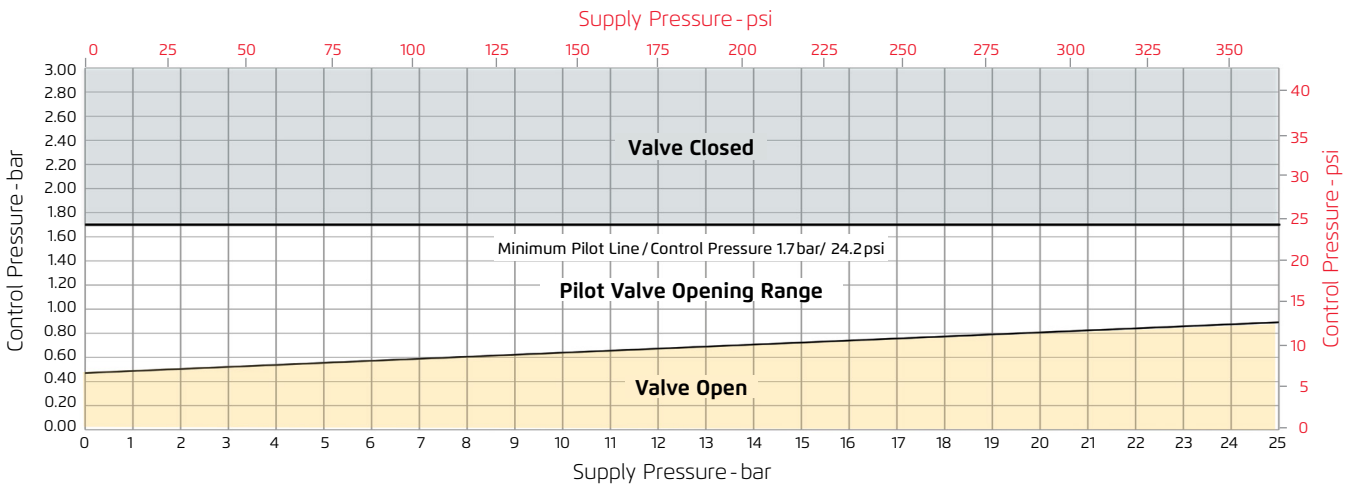

Model Codes and Material Options

Material Options		
Model Code	Body & Shaft (wetted)	Actuator / Covers (dry)
URV-2-0-N-N	Stainless Steel 316	Stainless Steel 316
URV-2-0-U-N	Ni.Aluminium Bronze (Monel shaft)	Stainless Steel 316
URV-2-0-U-U	Ni.Aluminium Bronze (Monel shaft)	Ni.Aluminium Bronze
URV-2-0-D-N	Super-Duplex	Stainless Steel 316
URV-2-0-T-N	Titanium	Stainless Steel 316

*For other material options contact BERMAD

