

IR-300 Basic Valve

The BERMAD basic diaphragm actuated Model IR-300/305 valve is a hydraulically operated globe valve in either the standard oblique (Y) or angle pattern design in diameter sizes of 1½-3"; DN40-DN80. Each valve comprises two major components: the body seat assembly and the actuator assembly.

The actuator assembly is unitized and is removable from the body as an integral unit. It consists of both an upper and a lower control chamber.

Each basic valve can easily be configured, on-site, either as a single chamber control valve (Model 305), or a double chamber control valve (Model 300). The shaft sub assembly, in both single and double chambered versions is center guided, providing an unobstructed seat area.

The Model 300 Basic double chambered valve operation is independent of valve differential pressure since the line pressure actually serves as the actuator differential pressure. This develops maximum power, ensuring immediate valve response. The upper control chamber is pressurized to close, and vented to open the valve. The lower control chamber is usually vented to the atmosphere, but can also be pressurized to power the valve open.

The main benefits of the double chambered valve are:

- Full-powered opening & closing
- Decreased pressure loss (no spring)
- Non-slam closing characteristic
- Isolated and protected diaphragm

The Model 305 Basic Valve uses valve differential pressure to power the actuator open or closed. The lower control chamber, which serves to cushion the closing of the valve, is exposed to the downstream pressure, through a fixed orifice connected to the downstream side of the valve. The pressure in the upper control chamber varies, resulting from the action of a solenoid or a regulating pilot. This varying pressure modulates the valve to open or close.



BERMAD Irrigation

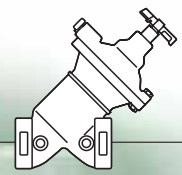

Principle of Operation

300 Series

On-Off Modes

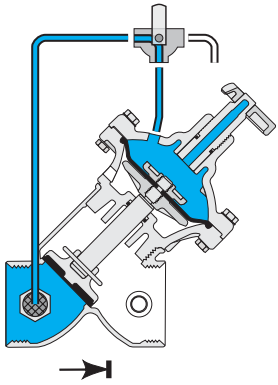

Closed Position

Line pressure applied to the control chamber of the valve creates a hydraulic force that moves the valve to the closed position and provides drip tight sealing.

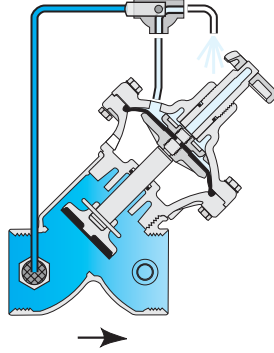

Open Position

Discharging the pressure from the control chamber to atmosphere or some other lower pressure zone, causes the line pressure acting on the seal disc to move the valve to the open position.

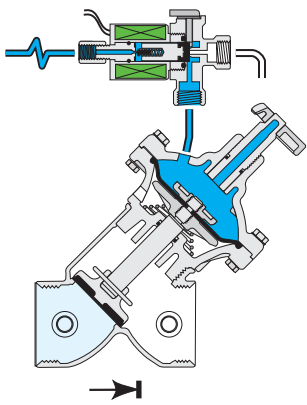

Lifting Spring & External Control

When line pressure is low while fully opening of the valve is required, line pressure is harnessed to powerfully open the valve. The external pressure applied through the opened solenoid to the upper control chamber, creates a hydraulic force that overcomes the lifting spring force, and thereby closes the valve. Closing the solenoid allows the lifting spring force to push the diaphragm assembly, thereby discharging the water from the upper control chamber, opening the valve.

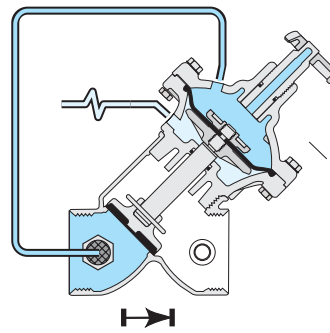
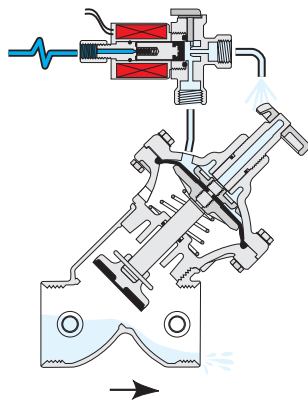

Normally Closed Valve with Hydraulic Power Opening

Line pressure is applied constantly to the Upper Control Chamber (UCC). When the Lower Control Chamber (LCC) is vented, it allows the line pressure in the UCC to push the diaphragm assembly, thereby discharging the water from the LCC, closing the valve. Pressurizing the LCC creates, together with the hydraulic force that acts on the plug, a superior force that overcomes the force in the UCC and opens the valve.

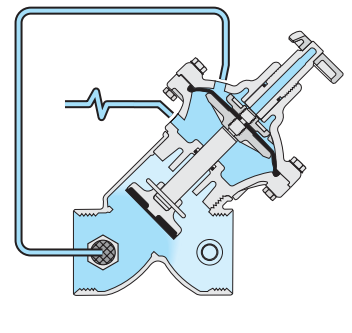

info@bermad.com • www.bermad.com

The information herein is subject to change without notice. BERMAD shall not be held liable for any errors. All rights reserved. © Copyright by BERMAD.

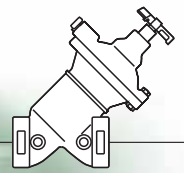

3-Way Control Modes

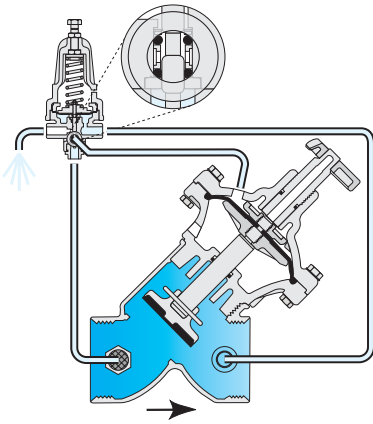

Fully Open Position

When upstream pressure drops, the pilot blocks the pressure port and opens the drain port, venting the control chamber to the atmosphere. This fully opens the valve, minimizing head loss.

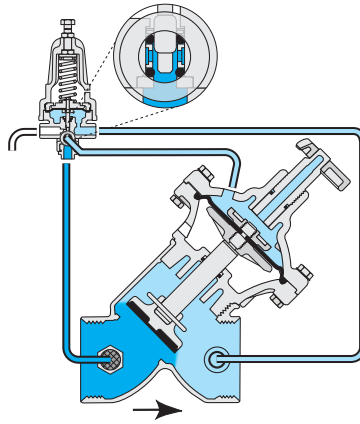

Modulating Closed

The pilot switches upon pressure rise, blocking the drain port and opening the pressure port. This pressurizes the control chamber, forcing the valve to modulate closed.

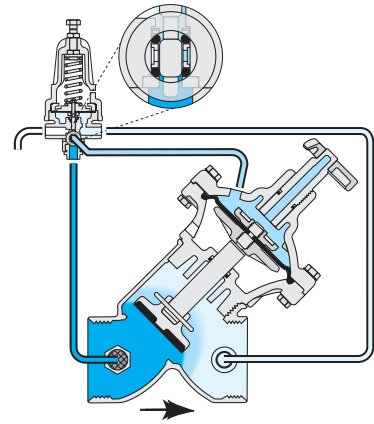

Locked Position

When sensed pressure is equal to setting, the pilot shaft moves and blocks both the drain port and the pressure port. This locks the pressure in the control chamber, freezing the valve in its last position until conditions change.

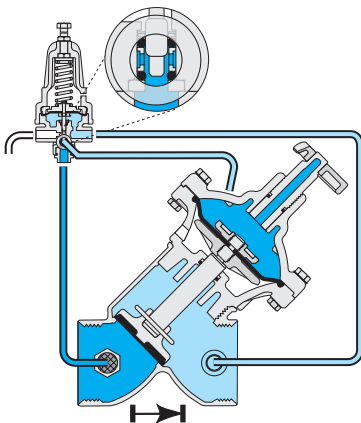

Zero Flow Position

When demand drops to zero, downstream pressure begins to rise as the flow enters a closed line. The pilot switches and pressurizes the control chamber initiating a valve's irreversible closing process, eventually causing it to seal drip tight.

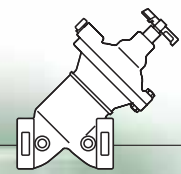

[1] Double Chambered Actuator

- Actuator assembly can be removed as one integral unit
- Simple on-site conversion to single chambered

[2] Cover Assembly

- [2.1] Optional cover type is capable of accepting a Flow Stem

[3] Diaphragm Assembly

The flexible nylon reinforced diaphragm is supported over the majority of its surface. Diaphragm load is limited to only the stretching forces applied to the active area.

[4] Inherent Separation Partition

The inherent separation provides complete central guiding for the valve moving assembly. The separation partition separates the lower control chamber from the flow in both the single chambered, and the double chambered configurations.

[5] Springs

Due to its superior hydraulic closing force, the double chambered actuator does not require an auxiliary closing spring, which is required for single chambered configurations.

An auxiliary opening spring can be applied for near zero-pressure applications with external control pressure.

- [5.1] Lifting Spring (for zero or near zero pressure applications)
- [5.2] Auxiliary Closing Spring (for single chambered valves only)

[6] Vulcanized Seal Disk

Self-aligning seal disk provides balanced, free movement and a resilient seal for perfect, drip tight sealing. The Seal disk is harnessed to the valve shaft by a stainless steel split pin.

Raised, full bore, clear of obstructions; no ribs or stem guides

[8] Valve Body ("Y" or Angle pattern)

Hydro-dynamically designed for efficient flow with minimal pressure loss. Semi-Straight flow increases capacity by 25% over standard globe valves.

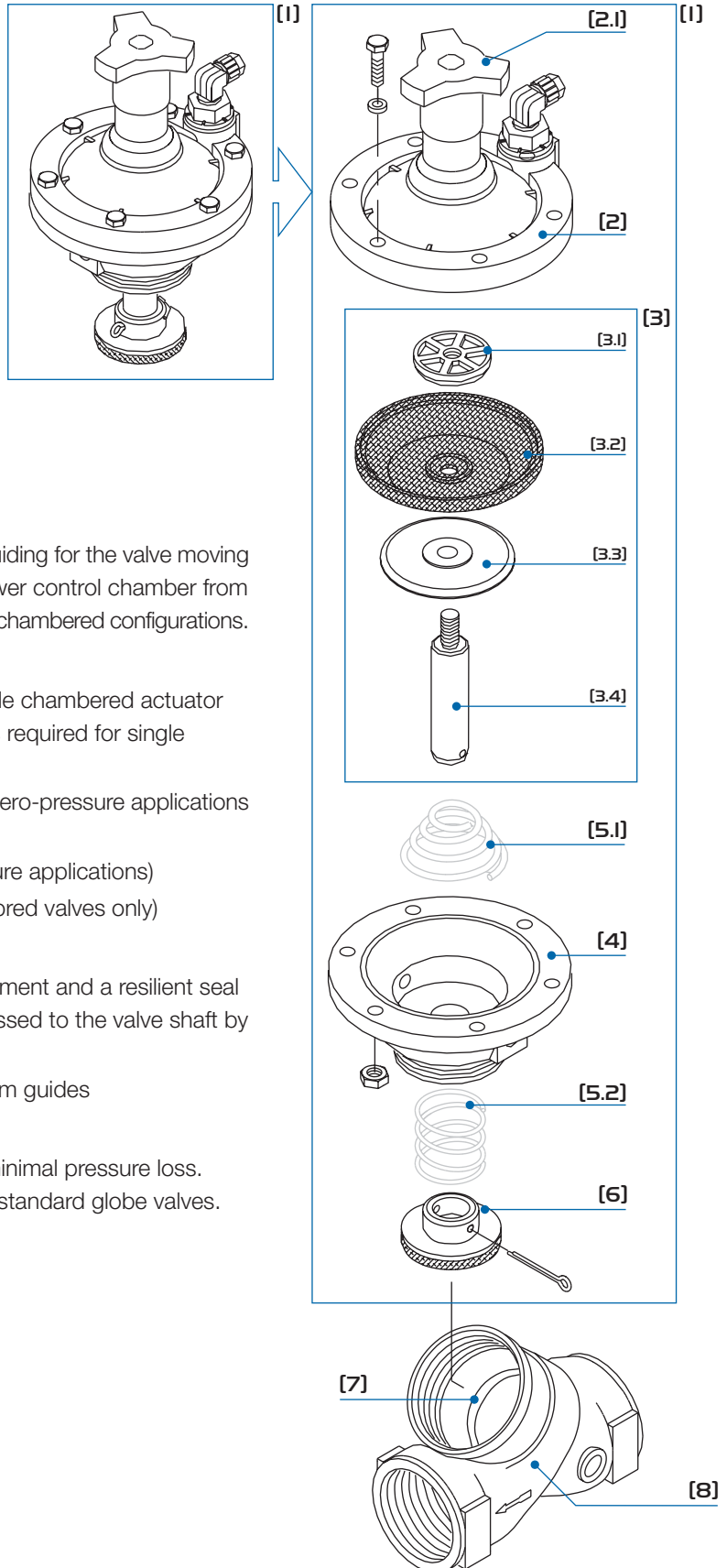

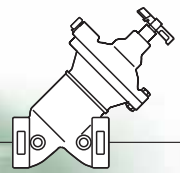

Dimensions & Weights

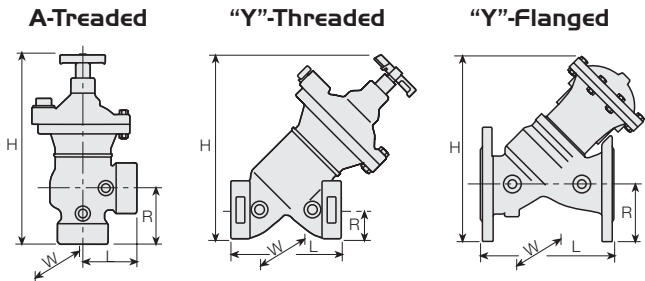

Connections Size	Threaded			Flanged	
	40	50	50 Angle	80	80
L (mm)	112	124	71	210	235
H (mm)	175	215	256	275	325
R (mm)	105	125	135	160	200
W (mm)	30	40	75	58	98
Weight (kg)	1.25	2.0	2.25	7.4	14.7
CCDV* (lit)	0.045	0.092	0.092	0.246	0.246

*Control Chamber Displacement Volume

Temperature Range:

Water up to 60°F

Standard Materials:

- Body: DN40 & 50 - Brass
DN80 - Polyester Coated Cast Iron
- Actuator: Plastic, Brass & Stainless Steel
- Diaphragm: Nylon Fabric Reinforced Natural Rubber
- Seals: NBR [Buna-N] & NR
- Spring: Stainless Steel
- Cover Bolts: Stainless Steel

Technical Specifications

Available Patterns & Sizes:

"Y": DN: 40, 50 & 80

Angle: DN50

End Connections:

Threaded: DN: 40, 50 & 80

Flanged: DN80

Pressure Rating: 10 bar

Operating Pressure Range: 0.7-10 bar

Flow Chart

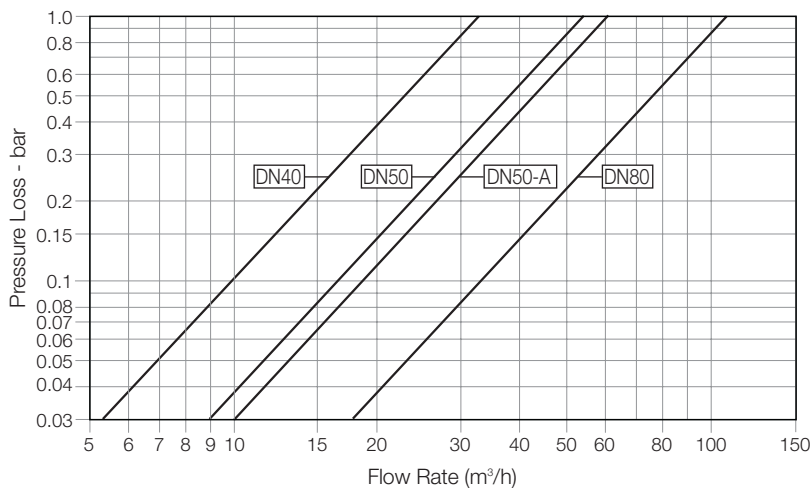

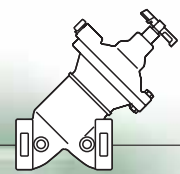

Dimensions & Weights

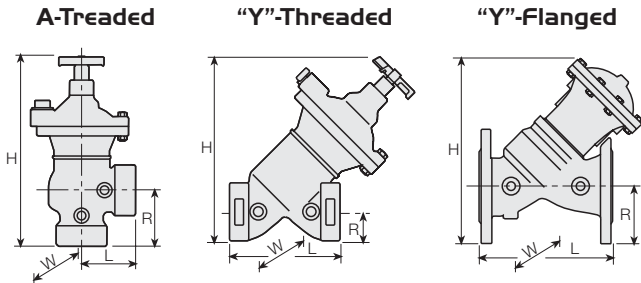

Pattern	Threaded			Flanged	
	Size	1 1/2"	2"	2" Angle	3"
L (mm)	47/16	47/8	2 13/16	8 1/4	9 1/4
H (mm)	6 7/8	8 7/16	10 1/16	10 13/16	12 13/16
R (mm)	4 1/8	4 15/16	5 5/16	6 5/16	7 7/8
W (mm)	1 3/16	1 9/16	2 15/16	2 5/16	3 7/8
Weight (lb)	2.75	4.4	5.0	16.3	32.4
CCDV* (gal)					

*Control Chamber Displacement Volume

Temperature Range:

Water up to 140°F

Standard Materials:

- Body: 1 1/2" & 2" - Brass
3" - Polyester Coated Cast Iron
- Actuator: Plastic, Brass & Stainless Steel
- Diaphragm: Nylon Fabric Reinforced Natural Rubber
- Seals: NBR [Buna-N] & NR
- Spring: Stainless Steel
- Cover Bolts: Stainless Steel

Technical Specifications

Available Patterns & Sizes:

"Y": 1 1/2", 2" & 3"

Angle: 2"

End Connections:

Threaded: 1 1/2", 2" & 3"

Flanged: 3"

Pressure Rating:

145 psi

Operating Pressure Range:

10-145 psi

Flow Chart

