

## Level Control Valve with 3-Way Altitude Pilot

(Sizes 1½-24"; DN40-600)

### Description

The Model 750-80-X Level Control Valve with 3-Way Altitude Pilot is a hydraulically operated, diaphragm actuated control valve that hydraulically shuts off at pre-set reservoir high level, and fully opens in response to an approximately one meter (three foot) level drop, as sensed by the 3-Way altitude pilot mounted on the main valve.

### Installation

1. Ensure enough space around the valve assembly for future maintenance and adjustments.
2. Prior to valve installation, flush the pipeline to insure flow of clean fluid through the valve.
3. For future maintenance, install Isolation gate valves upstream and downstream from Bermad control valve.
4. Install the valve in the pipeline with the valve flow direction arrow in the actual flow direction. Use the lifting ring provided on the main valve cover for installing the valve.
5. For best performance, it is recommended to install the valve horizontally and upright. For different valve positions – consult Bermad.
6. It is highly recommended to install a strainer Bermad model 70F upstream from the 780-X, to prevent debris from damaging valve operation.
7. Prepare a 1" female threaded "Hydrostatic level sensing port"; consist of a cock-valve and a filter, at a "still-point" at the bottom of the reservoir.  
**Note:** The drainage pipe might provide this "still-point", a location not influenced by flow velocity as in filling and outflow pipes.
8. Pull a ½" sensing tube, from the "level sensing port" at the bottom of the reservoir, to the valve. Install a ½" female thread adaptor at the valve-side end of the sensing tube. Ensure tube protection by a covered cable-canal. Apply a fixed effective tubes route.
9. Connect the control tube end, using ¾" copper or reinforced plastic tube, to the altitude pilot and to the "level sensing port", according to control drawing below.

### Commissioning & Calibration

1. Confirm that cock valves [1] is open (handle parallel to cock-valve body), and that cock valve [6] is directing the pilots to valve control chamber (according to the flow arrow on the handle)
2. Open fully the upstream and the downstream isolating valves & confirm that the supply pressure is typical.
3. Fill up the reservoir until the level reach its desired shut-off level.  
**Note:** To save the water & time involved with filling and emptying the reservoir, simulate upper & Low levels by temporary connecting a transparent plastic tube to the pilots sensing chambers. Locate the open-end of this tube at the reservoir roof, fill it with water to simulate the higher level and partially empty it to simulate the lower level.
4. Vent air from the valve's control loop & the pilot sensing chamber by loosening tube fittings at the highest points, allowing all air to bleed. Retighten the tube fittings eyebolts.
5. The Model 750-80-X is factory set according to the design upper level request. The set closing level is marked on the pilot's label.
6. Allow the 750-80-X to open by ensuring reservoir level is approximately 1 meter lower then the marked pilot setting, and fill-up the reservoir. Confirm the 750-80-X closes as level reaches the closing set level as marked on the pilot.
7. Simulate reservoir level drop as per the note at paragraph 3 above or allow the water level to drop by consuming from the reservoir or by draining it. Ensure the 750-80-X remains closed until water level drop approximately one meter (three foot) below the closing set level as marked on the pilot, switches at that point and opens fully.  
**Note:**
  - The 750-80-X opening process is involved with its control chamber drained to waste, through port [Z] of the pilot or (for 10"; DN250 valves and larger) port [1] of the 3W hydraulic relay valve [54B].
  - The opening level is not adjustable. It's a pilot fixed feature, which is activated approximately one-meter below the set shut-off level.
8. For changing the level setting, unlock the pilot locking nut and perform the below specified procedure:
  - 8.1. Turn cock valve [6] to "Close" position (flow arrow on the handle directing valve upstream to the valve control chamber).  
**Note:** The 750-80-X is now closed.
  - 8.2. Slowly turn the pilot adjusting screw Clock-Wise to the maximum spring compression.
  - 8.3. Simulate (or confirm – lower by consuming from the reservoir / raise by opening the 750-80-X) reservoir level to 30cm (1 foot) below the desired upper (closing) level.
  - 8.4. Disconnect the tube connected to the pilot port [C].
  - 8.5. Turn slowly the pilot adjusting screw Counter-Clock-Wise until water starts draining through its port [C]. Re-turn the pilot adjusting screw Clock-Wise until draining is stopped.
  - 8.6. Simulate (or raise) reservoir level to the desired upper (closing) level. The drain from pilot port [C] should restart.
  - 8.7. Re-connect the tube connected to pilot port [C] & reset cock valve [6] to "Open" position. Lock the pilot locking nuts.
9. To increase **opening speed** turn the pilot integral needle valve Counter-Clock-Wise.

## Control Drawing

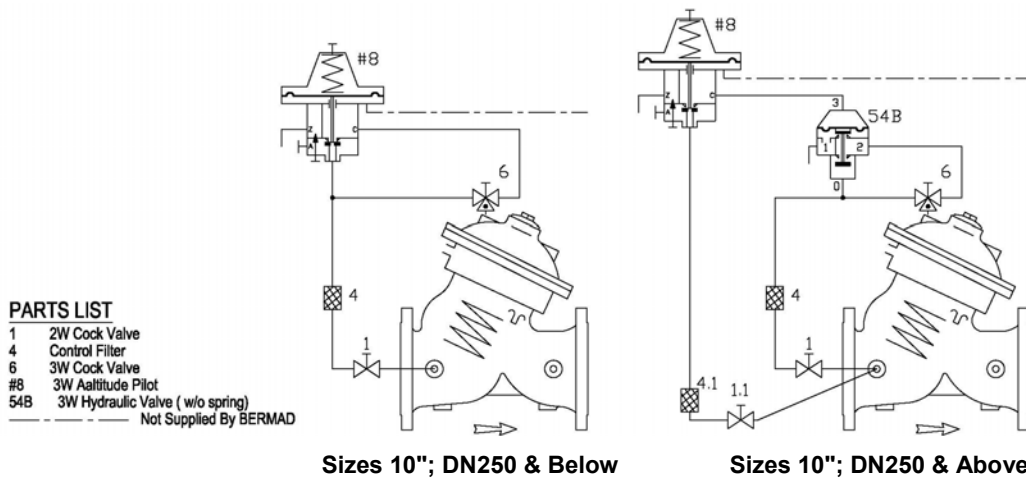

## Trouble-Shooting

- Valve fails to Open:** Check for sufficient inlet pressure, confirm pilot setting & reservoir level, check cock valve [6] status, check pilot needle valve opening rate, detect for clogged ports or fittings between valve & pilot.
- Valve fails to Close:** Confirm pilot setting & reservoir level, check cock valve [1] status, clean control filter & detect for clogged ports or fittings at control pressure branch, check if any debris trapped in the main valve, confirm diaphragm is not leaking.
- Valve fails to Regulate:** Check cock valves & needle valve status, release air trapped in the 750-80-X control chamber .

## Preventative Maintenance

- System operating conditions that effect on the valve should be checked periodically to determent the required preventative maintenance schedule.
- Maintenance instructions:
  - Tools required:
    - Metric and imperial wrenches
    - Anti seize grease
  - Visual inspection to locate leaks and external damages
  - Functional inspection including: closing, opening and regulation.
  - Close upstream and downstream isolating valves (and external operating pressure when used).
  - Once the valve is fully isolated vent pressure by loosening a plug or a fitting.
  - Open the stud nuts and remove the actuator as one unit from the valve body. Disassemble necessary control tubs.
  - It is highly recommended to stock a reserve actuator assembly for each size. This allows minimum system field work and system down time.
  - Disassemble the actuator and examine its parts carefully for signs of wear, corrosion, or any other abnormal conditions.
  - Replace worn parts and all the Elastomers. Lubricate the bolts and studs threads with Anti seize grease.

## Spare parts

Bermad has a convenient and easy to use ordering guide for valve spare-parts and control system components. For solenoid valves refer to model and S/N on solenoid tags.

Pub # : IOMEW750-80-X

By: YE 1/08

Rev: 01YE-1/08

File name: IOMEW750-80-X\_01\_08

[appliceng@bermad.com](mailto:appliceng@bermad.com) • [www.bermad.com](http://www.bermad.com)

The information contained in this document is subject to change without notice.

BERMAD shall not be liable for any errors contained herein. All Rights Reserved. © Copyright by BERMAD Control Valves.