

FP 400E Engineering Data

Description

The BERMAD FP 400E valve is an elastomeric, rolling diaphragm globe valve, with a solid radial seal disc. These automatic water control valves are designed for vertical or horizontal installation and are available in diameter sizes from 1½" to 14" (DN40 to DN350).

The BERMAD FP 400E valves are used for water flow control in Deluge, Combination Pressure Control Deluge, Preaction or Water/Foam systems. They are available in a wide range of construction materials, making them suitable for a variety of industrial specifications.

The FP 400E Deluge Valve is line pressure driven and is held closed by system water pressure trapped in the control chamber. When the releasing system operates, pressure is released from the control chamber, and the seal disc opens to allow water to flow into the system.

The design of the FP 400E valve body includes a single, full bore seat with an unobstructed flow path, free of any in-line ribs, supporting cage, or shafts.

The unique hydro-dynamic globe design provides high flow capabilities with minimum head loss. The cover is removable via four fastening bolts (6 bolts for 12" and 14" valves) for quick in-line inspection and servicing.

The internal design of the FP 400E valve is based on innovative VRSD (vulcanized radial seal disk) technology. This technology uses advanced rubber-based materials to achieve a solid, one-piece, elastomeric assembly including a flexible fiber reinforced diaphragm, vulcanized with a rugged radial seal disk, and together providing resilient, long term, drip tight sealing. The elastomeric assembly is carefully balanced and peripherally supported to avoid tension and protect the elastomer, resulting in long life and a smooth controlled actuation, even under harsh conditions.

The elastomeric assembly can be easily removed from the valve body with no need for disassembling the valve from the line.

Accessories

The BERMAD FP 400E Deluge Valve are trimmed with the original components and accessories per specification and in accordance with valve functions and applications.

Where additional specifications and/or signaling devices are required for a specific application, refer to system data for the system used, and to the BERMAD data sheet and Installation, Operation & Maintenance for specific model required.



Main Features

- Single piece molded elastomeric moving part – No maintenance required
- In-line serviceable, field replaceable internal parts
- Full bore and obstacle free flowpath
- Available in corrosion resistant materials
- Quick resetting without opening the valve
- Compatible with electric/hydraulic/pneumatic release and pressure control trim systems

Approvals

- UL Listed to UL 260 from 5 to 250 psi (0.3 to 17.2 bar) Working Pressure, 1-½" through 10" (DN40 through DN250)
- ABS Approved for 300 psi (21 bar) maximum working pressure, 1-½" through 14" (DN40 through DN350)
- Lloyd's Register Type Approval for 300 psi (21 bar) maximum working pressure, 1-½" through 14" (DN40 through DN350)
- Fire Test Certified to ISO 6182 part 5, 1-½" through 12" (DN40 through DN300)

Notes:

1. The FP 400E valve shall be trimmed with specific components & accessories.
2. The FP 400E valve must be installed and maintained in compliance with the most recent BERMAD publications.

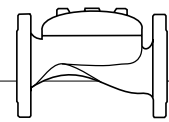

Construction Materials

The BERMAD FP 400E valves are available in a variety of materials to suit a wide range of application conditions. Providing the optimal resistance to corrosive media and harsh environments

To enable a higher corrosion resistance for ductile iron or cast steel valves, a UV protected high build fusion bonded epoxy coating is available as an option.

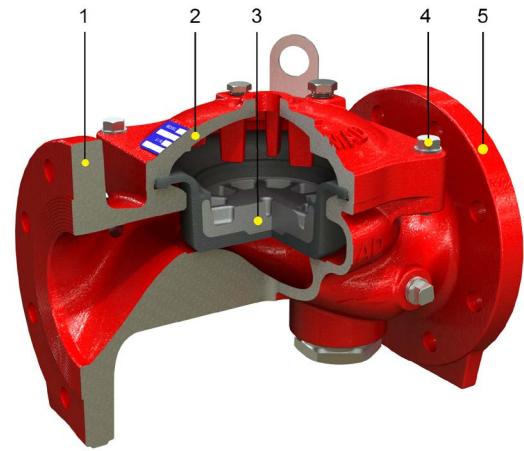

Standard Configurations

Item Number	Description	Code		
		FP-C-PR	FP-C-ER	FP-S-ER
1	Valve Body	Ductile Iron	Ductile Iron	Cast Steel
2	Cover	Ductile Iron	Ductile Iron	Cast Steel
3	Elastomeric Assembly	HTNR with VRSD*	HTNR with VRSD*	HTNR with VRSD*
4	External Bolts / Nuts	S.S. 316	S.S. 316	S.S. 316
5	Coating (external and internal)	Polyester	H.B. Epoxy	H.B. Epoxy

* VRSD - Vulcanized Radial Seal Disk

Specifications

Castings

- Ductile Iron to ASTM A536 65-45-12 (coated)
- Cast Steel ASTM A216 Grade WCB (coated)
- Nickel Aluminum Bronze ASTM B148 C95800
- Stainless Steel 316 ASTM A351 Grade CF8M
- Hastelloy C-276

Standard Bolting:

- Stainless Steel 316 to ASTM A276

Option: Internal Spring - S.S. 302 or Inconel

Elastomer

- HTNR, Polyamide fabric reinforced Polyisoprene, Temperature Rating up to 80°C
- NBR, Polyamide fabric reinforced Nitrile (Buna-N), Temperature Rating up to 80°C
- EPDM, Polyamide fabric reinforced Ethylene-Propylene, Temperature Rating up to 90°C

Coating

- Electrostatically Applied Polyester Powder Coating
- High Build, Fusion Bonded and UV Protected, Epoxy Coating
- Color: Fire Red to RAL 3002

Pressure Rating

Material	End Connection Standard Inlet & Outlet	Class & Type	Max. working Pressure In superscript: (3)	
			psi	bar
Ductile Iron	Flanged ANSI B16.42	#150RF	250	17.2
	Flanged ISO 7005-2	PN16	235	16
	Grooved ANSI C606	250	250	17.2
	Grooved BS EN 10255	250	250	17.2
Cast Steel	Threaded ISO-7-RP/NPT	250	250	17.2
	Flanged ANSI B16.5	#150RF	250	17.2
	Flanged ISO 7005-2	PN16	235	16
Stainless Steel	Flanged ANSI B16.5	#150RF	250	17.2
	Flanged ISO 7005-2	PN16	235	16
Ni-Al Bronze	Flanged ANSI B16.24	#150RF	250	17.2
	Flanged ISO 7005-2	PN16	235	16

Notes:

1. To attach a grooved valve to flanged line or vice versa, use a grooved-flange adapter suited to the designated conditions.
2. Factory pressure testing: Each valve is tested at 375 psi (26 bar)
3. Max working pressure to be in accordance with pressure temperature rating of the relevant standard
4. Standard flange facing: Raised Face (RF), Serrated Finish. Flat Face (FF) flanges available on request.

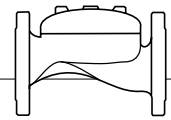

Flow Chart

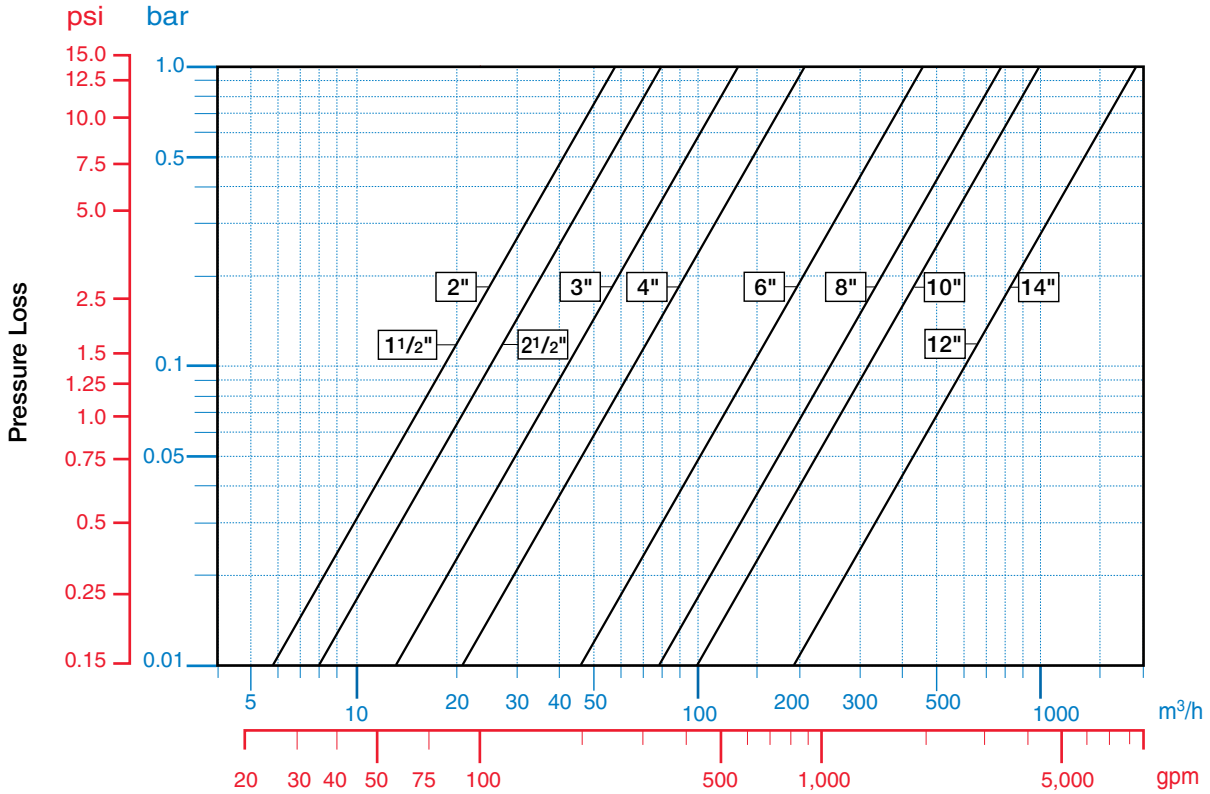

Flow Properties

DN	40	50	65	80	100	150	200	250	300	350
Inch	1 1/2"	2"	2 1/2"	3"	4"	6"	8"	10"	12"	14"
Kv	57	57	78	136	204	458	781	829	1,932	1,932
Cv	66	66	90	157	236	529	902	957	2,231	2,231
K	3.2	3.2	4.2	2.9	4.0	4.0	4.4	3.9	3.6	3.6
Leq-m	9.1	9.1	12.1	13.7	14	27.4	45.8	108	57	57
Leq-feet	30	30	40	45	46	90	150	354	187	187

Valve flow coefficient, Kv or Cv $Kv(Cv) = Q \sqrt{\frac{G_f}{\Delta P}}$

Where:
 Kv = Valve flow coefficient (flow in m³/h at 1bar Diff. Press.)
 Cv = Valve flow coefficient (flow in gpm at 1psi Diff. Press.)
 Q = Flow rate (m³/h; gpm)
 ΔP = Differential pressure (bar; psi)
 Gf = Liquid specific gravity (Water = 1.0)

Cv = 1.155 Kv

Flow resistance or Head loss coefficient, $K = \Delta H \frac{2g}{V^2}$

Where:
 K = Flow resistance or Head loss coefficient (dimensionless)
 ΔH = Head loss (m; feet)
 V = Nominal size flow velocity (m/sec; feet/sec.)
 g = Acceleration of gravity (9.81 m/sec²; 32.18 feet/sec²)

Equivalent Pipe Length, Leq $Leq = Lk \cdot D$

Where:
 Leq = Equivalent nominal pipe length (m; feet)
 Lk = Equivalent length coefficient for turbulent flow in clean commercial steel pipe (SCH 40)
 D = Nominal pipe diameter (m; feet)

Note:
 The Leq values given are for general consideration only. Actual Leq may vary somewhat with each of the valve sizes.



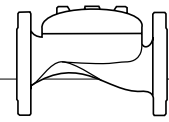

SI / Metric

Flanged

Size DN mm (inch)		40 (1½")	50 (2")	65 (2½")	80 (3")	100 (4")	150 (6")	200 (8")	250 (10")	300 (12")	350 (14")
ANSI #150, ISO PN 16	LF (mm)	205	205	205	257	320	415	500	605	725	741
	W (mm)	155	155	178	200	223	306	365	405	610	597
	H (mm)	74	74	86	110	130	205	256	256	373	373
	RF (mm)	64	76	92.5	100	116	140	172	203	242	267
	a ⁽¹⁾ (inch)	½	½	½	½	½	½	½	½	½	½
	b ⁽¹⁾ (inch)	¼	¼	¼	¼	¼	¼	¼	¼	¼	¼
	c ⁽¹⁾ (inch)	½	½	½	½	½	½	½	½	½	½
	d ⁽²⁾ (inch)	¾	¾	1.5	1.5	2	2	2	2	2	2
	Control Vol. ⁽³⁾ (ltr)	0.12	0.12	0.18	0.29	0.67	1.94	3.86	3.86	13.8	14
	Weight (Kg)	8	9	10.5	19	28	68	125	140	220	235

Grooved

Size DN mm (inch)		50 (2")	80 (3")	100 (4")	150 (6")	200 (8")
Grooved	LG (mm)	205	250	320	415	500
	W (mm)	120	175	200	306	365
	H (mm)	74	110	130	205	256
	RG ANSI C606 (mm)	30.2	44.5	57.2	84.2	110
	RG BS EN 10255 (mm)	30.2	44.5	57.2	82.6	110
	a ⁽¹⁾ (inch)	½	½	½	½	½
	b ⁽¹⁾ (inch)	¼	¼	¼	¼	¼
	c ⁽¹⁾ (inch)	½	½	½	½	½
	d ⁽²⁾ (inch)	¾	1½	2	2	2
	Control Vol. ⁽³⁾ (ltr)	0.12	0.29	0.67	1.94	3.86
Weight (Kg)	5	10.6	16.2	49	108	

Threaded

Size DN mm (inch)		40 (1½")	50 (2")	65 (2½")
ISO-7-Rp or NPT(F)	LT (mm)	180	180	210
	W (mm)	120	120	129
	H (mm)	74	74	87
	RT (mm)	30	37.5	40
	a ⁽¹⁾ (inch)	½	½	½
	b ⁽¹⁾ (inch)	¼	¼	¼
	c ⁽¹⁾ (inch)	½	½	½
	d ⁽²⁾ (inch)	¾	¾	1½
	Control Vol. ⁽³⁾ (ltr)	0.12	0.12	0.18
	Weight (Kg)	4	4	5.7

- (1) (a), (b), (c) are NPT Thread ports
 (2) (d) is BSPT threaded drain port
 (3) (Control Volume) is the Volume of Liquid expelled from the control chamber when valve opens

Flanged

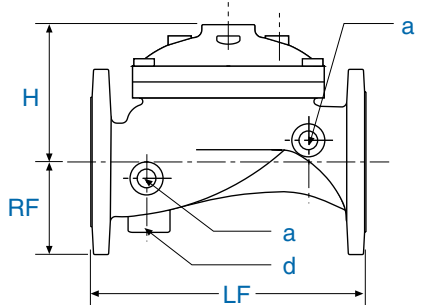

Grooved

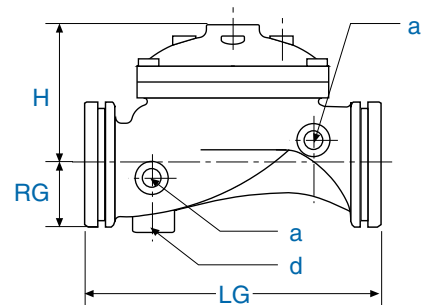

Threaded

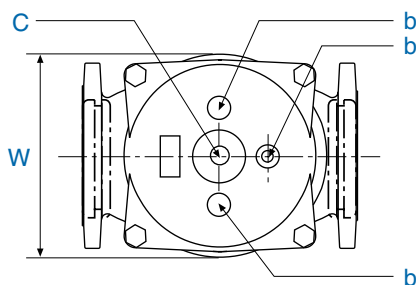
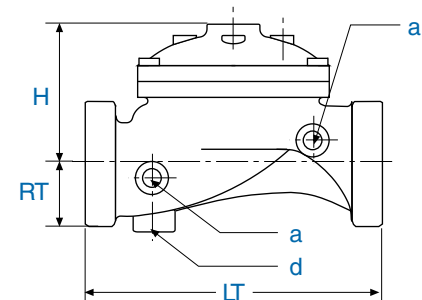

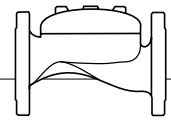

US Customary Units

Flanged

Size (inch)	1½	2	2½	3	4	6	8	10	12	14	
ANSI #150, ISO PN 16	LF (inch)	8 ¹ / ₈	8 ¹ / ₈	8 ¹ / ₈	10 ¹ / ₈	12 ⁵ / ₈	16 ³ / ₈	19 ⁵ / ₈	23 ¹³ / ₁₆	28 ⁴ / ₈	29 ¹ / ₈
	W (inch)	6 ¹ / ₈	6 ¹ / ₈	7	7 ⁷ / ₈	8 ⁶ / ₈	12	14 ³ / ₈	16	24	23 ⁴ / ₈
	H (inch)	2 ⁷ / ₈	2 ⁷ / ₈	3 ³ / ₈	4 ³ / ₈	5 ¹ / ₈	8 ¹ / ₈	10 ¹ / ₈	10 ¹ / ₈	14 ⁵ / ₈	14 ⁵ / ₈
	RF (inch)	2 ⁴ / ₈	3	3 ⁵ / ₈	3 ⁷ / ₈	4 ⁵ / ₈	5 ⁴ / ₈	6 ⁶ / ₈	8	9 ⁴ / ₈	10 ⁴ / ₈
	a ⁽¹⁾ (inch)	½	½	½	½	½	½	½	½	½	½
	b ⁽¹⁾ (inch)	¼	¼	¼	¼	¼	¼	¼	¼	¾	¾
	c ⁽¹⁾ (inch)	½	½	½	½	½	½	½	½	½	½
	d ⁽²⁾ (inch)	¾	¾	1.5	1.5	2	2	2	2	2	2
	Control Vol. ⁽³⁾ (Gal.)	0.03	0.03	0.05	0.08	0.18	0.51	1.02	1.02	3.65	3.70
	Weight (Lbs.)	18	20	23	42	62	150	276	309	485	518

Grooved

Size (inch)	2	3	4	6	8	
Grooved	LG (inch)	8 ¹ / ₁₆	9 ³ / ₁₆	12 ⁵ / ₈	16 ⁵ / ₁₆	19 ⁵ / ₈
	W (inch)	4¾	6 ⁷ / ₈	7 ⁷ / ₈	12 ¹ / ₁₆	14 ³ / ₈
	H (inch)	2 ¹⁵ / ₁₆	4 ⁵ / ₁₆	5 ¹ / ₈	12 ⁹ / ₁₆	10 ¹ / ₈
	RG ANSI C606 (inch)	1 ³ / ₁₆	1¾	2¼	35/16	4 ³ / ₈
	RG BS EN 10255 (inch)	1 ³ / ₁₆	1¾	2¼	3¼	4 ³ / ₈
	a ⁽¹⁾ (inch)	½	½	½	½	½
	b ⁽¹⁾ (inch)	¼	¼	¼	¼	¼
	c ⁽¹⁾ (inch)	½	½	½	½	½
	d ⁽²⁾ (inch)	¾	1½	2	2	2
	Control Vol. ⁽³⁾ (Gal.)	0.03	0.08	0.18	0.51	1.02
	Weight (Lbs.)	11	23	36	108	238

Threaded

Size (inch)	1½	2	2½	
ISO-7-Rp or NPT(F)	LT (inch)	7 ¹ / ₁₆	7 ¹ / ₁₆	8 ¹ / ₄
	W (inch)	4¾	4¾	5 ¹ / ₁₆
	H (inch)	2 ⁷ / ₈	2 ¹⁵ / ₁₆	3 ⁷ / ₁₆
	RT (inch)	1 ³ / ₆	1 ⁹ / ₁₆	1 ⁹ / ₁₆
	a ⁽¹⁾ (inch)	½	½	½
	b ⁽¹⁾ (inch)	¼	¼	¼
	c ⁽¹⁾ (inch)	½	½	½
	d ⁽²⁾ (inch)	¾	¾	1½
	Control Vol. ⁽³⁾ (Gal.)	0.03	0.03	0.05
	Weight (Lbs.)	9	9	13

(1) (a), (b), (c) are NPT Thread ports

(2) (d) is BSPT threaded drain port

(3) (Control Volume) is the Volume of Liquid expelled from control chamber when valve opens

Flanged

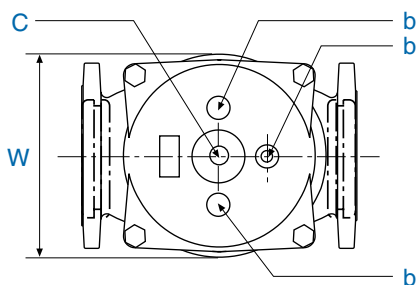
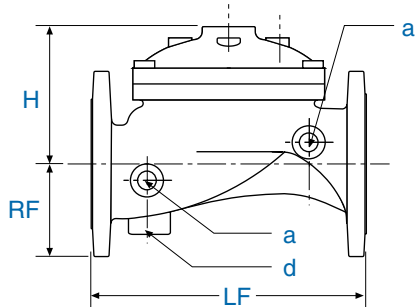

Grooved

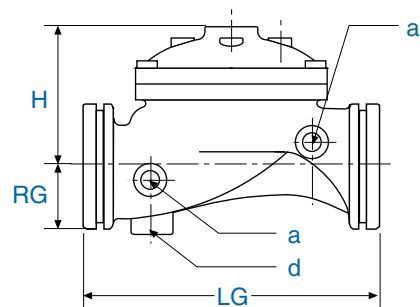

Threaded

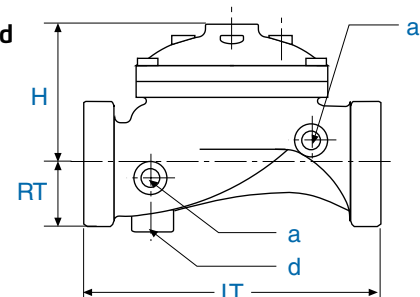

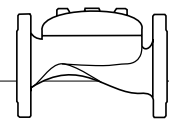

Installation

Proper operation of the FP 400E Deluge Valves depends upon their trim being installed in accordance with the appropriate trim configuration.

Notes:

- Wet pilot height should not exceed "Maximum Elevation Above Valve" (see data for specific model).
- Any deviation in trim size or arrangement may adversely affect the proper operation of the deluge valve.
- All the pilot system devices, must be UL Listed and compatible with the particular deluge system. Refer to current "UL Listed Fire Protection Equipment Directory".

Warning: The deluge valve and trim must be installed only in areas where they will not be subject to freezing temperatures.

Installation Instructions

1. Allow enough room around the valve assembly for any adjustments and future maintenance.
2. Before the valve is installed, flush the pipeline to remove any dirt, scale, debris, etc. Not flushing the line may result in the valve being rendered inoperable.
3. Install the valve in the pipeline so that the valve flow arrow appearing on the body casting is pointing in the desired direction. Ensure that the valve is positioned so that the cover can be easily removed for future maintenance.
4. Ensure that the Control Trim is mounted properly and all other components are positioned correctly as per illustration.
5. After installation in the main line, carefully inspect/correct any damaged accessories, piping, tubing, or fittings. Ensure that there are no leaks.
6. Install the components comprising the Deluge Trim Package in their proper positions in compliance with all instructions, drawings, and technical specifications describing the BERMAD Deluge Valve, according to the relevant illustration.
7. All additional accessories, although not packed together with the BERMAD Deluge Valve, must be installed as shown in the relevant P&ID and other illustrations.

Operation

Principle of Operation

The BERMAD FP 400E Deluge Valve (assembled with specific trim) is suitable for systems that include adequate detecting and piping systems with open nozzles. The deluge valve prevents water from entering system piping until required. The deluge valve is kept

closed by pressure applied to the control chamber through a restricted priming line.

In the SET position, the water pressure supplied through the priming line is trapped in the control chamber of the deluge valve by a check valve, and by the normally closed release device.

The pressure trapped in the control chamber of the deluge valve presses the valve seal disc down, thereby sealing the valve and keeping the system piping dry. Under Test or Fire conditions, when the pressure is released from the control chamber by the opening of the automatic releasing device or by manual release, the deluge valve opens and allows the inlet supply water to flow through the valve and into the system piping and alarm devices.

Warning: Whenever the handle of the Manual Emergency Release is pulled, pressure is released from the control chamber, the deluge valve will open, and water will flow into system piping and alarm devices.

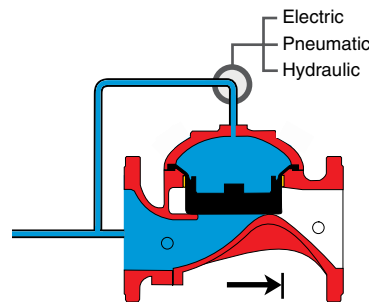

Valve Closed (Set Position)

Line pressure applied to the control chamber of the valve creates a superior force that moves the valve to the closed position and provides drip tight sealing.

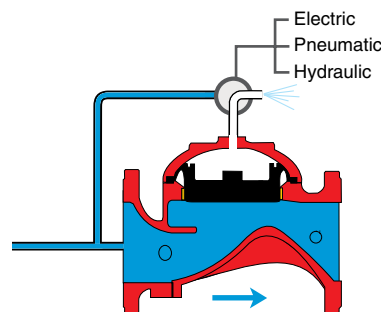

Valve Open (Operating Conditions)

Releasing the pressure from the control chamber to atmosphere or some other lower pressure zone causes the line pressure acting on the seal disc to move the valve to the open position.

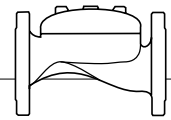

Placing in Service/Resetting

The deluge valve and the control trim shall be placed in service with accordance to the most recent IOM procedures for the specific model.

After all relevant instructions are performed, slowly open the supply-isolating valve and check that no water flows into the system.

The system is now operational and in stand-by mode.

Maintenance

Bermad Deluge Valves require no lubrication, no packing tightening, and require minimum maintenance.

Removing the System from Service

Warning: When taking a deluge system out of service, a fire patrol should be established in the system area. If automatic fire alarm signaling equipment is utilized, the proper authority should be notified that the system is being removed from service. The insuring body and owner's representative should also be notified when the system is being taken out of service.

Inspection and Testing

1. **Warning:** Do not turn the water supply off to make repairs without placing a roving fire patrol in the area covered by the system. The patrol should continue until the system is back in service.
2. Prior to turning off any valves or activating any alarms, notify local security guards and the central alarm station, if used, to avoid signaling a false alarm.
3. The deluge valve and the control trim shall be maintained with accordance to the most recent IOM procedures for the specific model. A periodic test schedule should be established also with accordance to the site conditions and owner regulations.
4. Take all additional measures as required by NFPA-25 "standard for the inspection, testing, and maintenance of water-based fire protection systems".
5. The system should be checked weekly for "Normal Conditions".
6. Clean the priming strainer prior to any resetting of the deluge valve.
7. The deluge valve must be activated at full flow at least annually. Take all necessary precautions to drain water and prevent damage in the area protected by the system.
8. After about five years of operation, replacement of the diaphragm assembly is recommended. Remove the cover, clean the valve body from sediments, clean the control tubing entry holes, and install a new diaphragm assembly in place.

Removal Instructions

1. Shut off the main supply-isolating valve.
2. Close the priming line valve to the deluge valve control chamber.
3. Open all drain valves.
4. Release the water pressure from the control chamber of the deluge valve by pulling the manual emergency release.
5. Place "Fire Protection System Out of Service" signs in the area protected by the system.

Spare Parts

1. The Diaphragm Assembly is the only spare part needed for the main deluge valve, see "Exploded View" in the following page.
2. It is not recommended to store spare rubber parts for long periods (rubber in improper storage conditions can harden and crack).
3. Contact your Bermad representative and order new rubber parts when required.

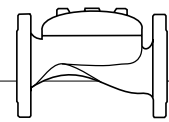

Exploded View

