

Fire Pump Control and Check Valve

Model 42T-20

The BERMAD model 42T-20 is an elastomeric, hydraulically operated, self actuated automatic pressure control valve with a check valve feature. This valve is designed for advanced fire protection systems in accordance with the NFPA-13 and NFPA-20 guidelines.

The 42T-20 is used for controlling the flow and pressure at the pump discharge, performing also as a non return check valve.

The 42T-20 prevents pump water surge pressure spikes, typically caused by the accelerated water flow during fire pump start-up.

In addition this valve will significantly reduce pump start negative suction pressure, preventing pump cavitation damage.

Due to exceptional reliability, safe actuation and low head loss, the 42T-20 is highly suited for fire pump discharge pressure control applications.

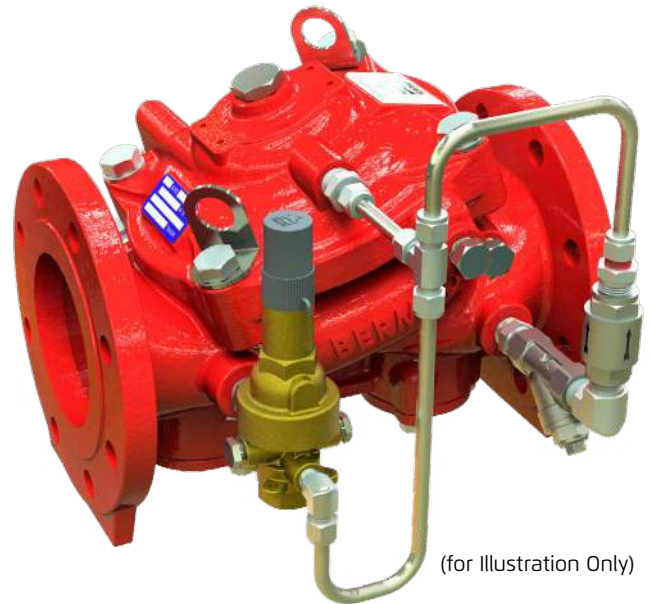

Benefits and Features

- **Safety and reliability**
 - Time-proven, simple, safe actuation
 - Single piece, rugged, elastomeric VRSD technology
 - Obstacle-free, uninterrupted flow path
 - stem-less guide with no mechanical moving parts
- **High performance**
 - Straight-through flow with Minimal pressure / energy loss
 - Cost effective
 - Fast, smooth response to pressure changes
 - Certified for 20/25 bar (300/365 psi)
- **Designed for advanced fire protection systems**
 - Meets the requirements of the NFPA 13 and the NFPA-20 standards
 - Face-to-face length standardized to ISO 5752, EN 558-1
- **Quick and easy maintenance**
 - In-line serviceable
 - No mechanical moving parts
 - Quick cover removal without detaching control trim

Typical Applications

- Pump discharge control
- Fire Pump surge prevention
- Sprinkler feed systems
- Branch pressure regulating and check valve
- Foam Systems

Approvals



UL-Listed
Special System Water Control
Valves, Pressure Reducing (VLMT)
Sizes 1½" - 16"



FM Approved
Pressure Reducing Valves
Sizes 1½" -10"



Det Norske Veritas
(Type Approval)



ABS
American Bureau of Shipping
Type Approval



Lloyd's Register
Type Approval

Additional Features

- Sea water compatibility
- Large control filter for dirty water supply
- High Build epoxy coating
- Stainless steel seat ring
- Valve linear position indicator/switch



BERMAD Fire Protection

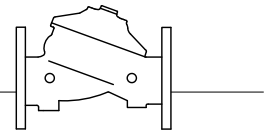

400Y Series

Model FP 400Y - 42T-20

Operation

(for illustration only)

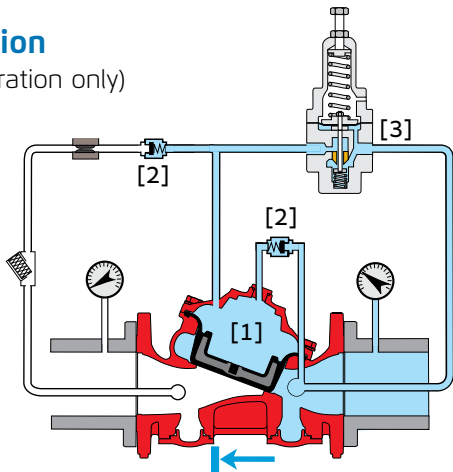

Valve Closed - The BERMAD 42T-20 control valve is kept shut tight when the main pump is idle by way of the jockey or maintenance pump pressure held in the valve's control chamber [1] by the check valves [2]. Under the same principle the 42T-20 acts as a system non-return valve, preventing water from flowing back to the main pump after pump shut down.

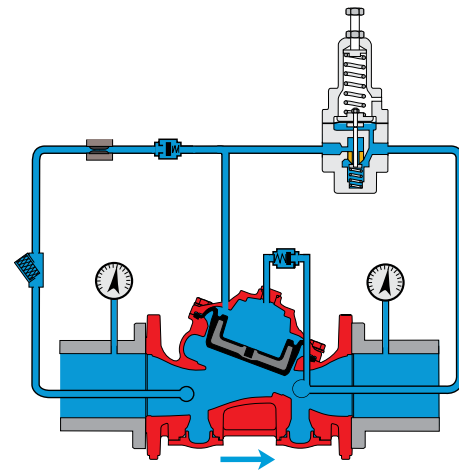

Valve Open - At pump start up the energy of the initial surge from the pump start will be arrested by the closed valve, preventing downstream pressure spikes and water surge in the system piping. The valve will continue to open in a controlled manner as pressure is released from the valve control chamber through the pilot valve [3] (see graph below).

In the graph opposite the red line shows the spike in system pressure at pump start. The blue line shows the system pressure at pump start after installation of the BERMAD 42T-20 with no spike in system pressure.

System pressure at Pump Start
With and without 42T-20 Pump Control Valve

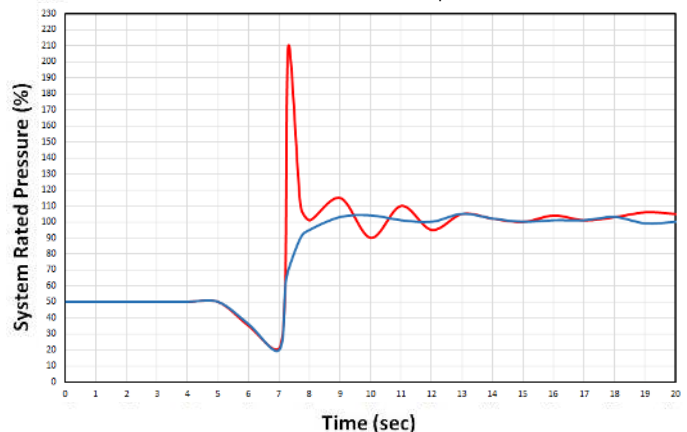

The 42T-20 acts as a surge protection valve and a system non return valve. In addition, if required the 42T-20 pilot [4] can be adjusted to control the outlet pressure ensuring a stable and precise pre-set downstream pressure regardless of flow or pressure fluctuations.

System P&ID

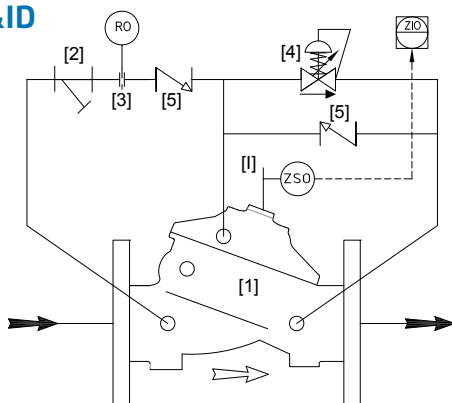

Components

- 1. BERMAD 400Y valve
- 2. Y Control filter
- 3. Restriction orifice
- 4. Pilot valve
- 5. Check valve

Optional System Items*

- I Visual indicator
- ZSO Limit switch

* See also factory fitted items under the *Valve Code Designations* on the last page



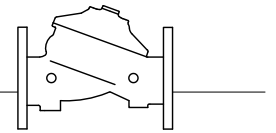

System Installation

A typical installation of the BERMAD model 42T-20 is where the valve is installed downstream of the fire pump discharge isolation valve.

The jockey pump discharge pipe shall be connected downstream of the BERMAD 42T-20 control valve.

The 42T-20 is especially suited for this fire pump function, having an exceptionally high flow capacity and low pressure loss, owing to the unobstructed internal elastomeric construction and straight through flow path.

When the 42T-20 is fully open, it presents the least possible pressure loss delivering the maximum volume of firewater to the extinguishing devices.

The BERMAD 400Y 42T-20 has the high operational reliability inherent with elastomeric valves not having any bearings or shafts that might stick if the valve is to be dormant for long periods, as is often the case with fire protection systems. In addition the peripherally supported VRSD diaphragm (Vulcanized Radial Seal Disk) ensures many years of trouble-free high pressure performance.

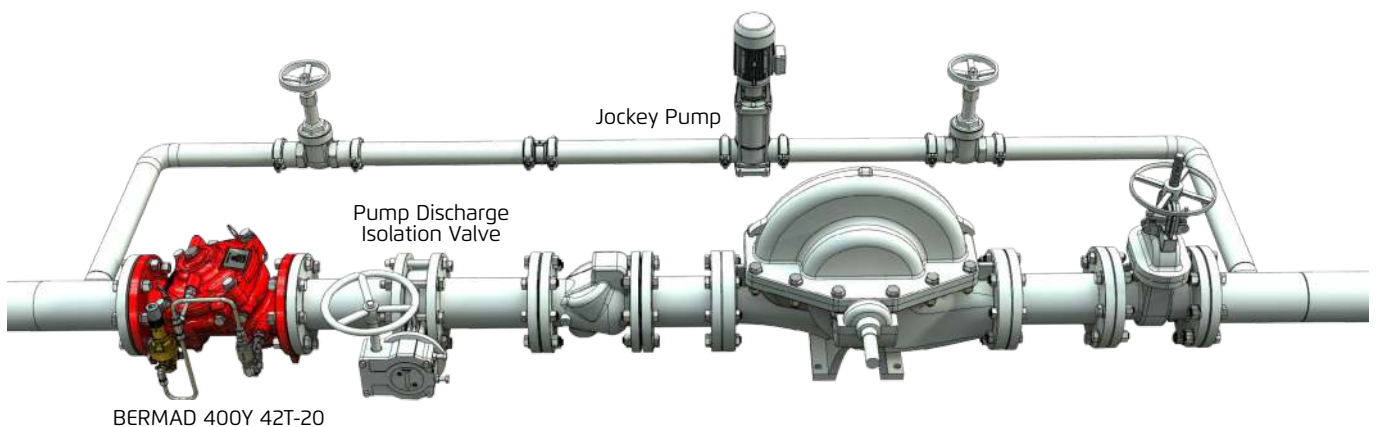

BERMAD 400Y 42T-20

(for illustration Only)

Engineer Specifications

The Fire Pump Control Valve shall be suitable to control the flow and pressure at the pump discharge, performing also as a non return check valve.

The Control Valve shall be UL listed and FM Approved as a Pilot Operated Pressure Control Valve with a Check Valve feature for fire protection, meeting the NFPA-13 and NFPA-20 guidelines.

The valve shall be with a straight-through body design and shall have an unobstructed flow path, with no stem guide or supporting ribs.

Valve actuation shall be accomplished by a single-piece, rolling diaphragm bonded with a rugged radial seal disk that shall be the only moving part.

The cover and valve body shall be ductile iron to ASTM A536 GR 65-45-12 coated internally and externally with a high build corrosion resistant epoxy coating.

The valve pilot system shall include a Balanced Pressure Control Pilot Valve, Y-type strainer, spring return check valve, a restrictor and Stainless Steel 316 tubing and fittings.

Removing the valve cover for inspection or maintenance shall be inline and shall not require removal of the control trim.

The valve and its entire control trim shall be supplied pre-assembled and hydraulically tested by a factory certified to ISO 9000 and 9001 standards.

BERMAD Fire Protection

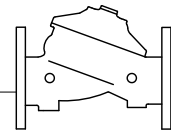

Model FP 400Y - 42T-20

400Y Series

Technical Data

Available Sizes (inch)

- Flanged - 1½, 2, 2½, 3, 4, 6, 8, 10, 12, 14 & 16"
- Grooved - 1½, 2, 2½, 3, 4, 6, 8"
- Threaded - 1½ & 2"

Pressure Rating

- ANSI#150 - 17.2 bar / 250 psi
- ANSI#300 - 1½, 2 & 2½" 28 bar / 400 psi (*)
3" to 10" 25 bar / 365 psi
12" to 16" 20 bar / 300 psi
- Grooved: 1½, 2 & 2½" - 28 bar / 400 psi (*), 3" to 8" 25 bar / 365 psi
- Threaded: 1½ & 2" - 28 bar / 400 psi (*)
- Setting range: 4 - 12 bar (60 - 175 psi)

* the 1½, 2 & 2½" valves are UL-Listed for 28 bar/400 psi, and FM Approved for 25 bar/365 psi

Elastomer

- HTNR - Fabric Reinforced High Temperature Compound - See engineering data

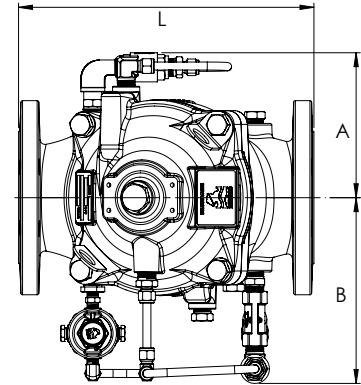
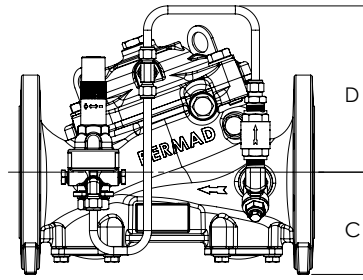

Valve Size	1½" DN40		2" DN50		2½" DN50		3" DN80		4" DN100		6" DN150		8" DN200		10" DN250		12" DN300		14" DN350		16" DN400	
	mm	in	mm	in	mm	in	mm	in	mm	in	mm	in	mm	in	mm	in	mm	in	mm	in	mm	in
L ⁽¹⁾	230	9.1	230	9.1	235	9.25	310	12.2	350	13.8	480	18.9	600	23.6	730	28.7	850	33.5	980	38.6	1100	43.3
L ⁽²⁾	230	9.1	238	9.4	241	9.37	326	12.8	368	14.5	506	19.9	626	24.6	730	28.7	888	35	980	38.6	1100	43.3
A	132	5.2	135	5.3	137	5.4	155	6.1	170	6.7	180	7	190	7.5	204	8	242	9.53	242	9.53	242	9.53
B	155	6.1	155	6.1	187	7.4	251	9.88	266	10.47	372	14.65	490	19.29	490	19.29	656	25.83	656	25.83	656	25.83
C	64	2.52	77	3.03	92	3.62	106	4.17	121	4.76	140	5.51	172	6.77	204	8.03	247	9.72	272	10.71	316	12.44
D	146	5.8	146	5.8	146	5.8	146	5.75	158	6.22	228	9	295	11.65	296	11.65	441	17.36	441	17.36	415	16.3
Kv / Cv ⁽⁴⁾	68 / 79		80 / 92		105 / 121		190 / 219		345 / 398		790 / 912		1160 / 1340		1355 / 1565		2370 / 2737		2850 / 3292		3254 / 3758	
Leq ⁽³⁾ : m/ft	2 / 7		4 / 14		9 / 31		7 / 23		9 / 30		15 / 49		27 / 89		62 / 203		52 / 171		59 / 194		88 / 289	
Kg/lb flanged#150/ISO16	17.9 / 39.4		19.3 / 42.5		23 / 50		34 / 74.8		44 / 95.8		87.3 / 192		150 / 331		180 / 397		323 / 712		356 / 784		403 / 886	

Notes: ⁽¹⁾ Refers to the length dimensions for Raised Face ANSI #150, ISO 16 Flanged, Threaded Grooved valves

⁽²⁾ Refers to the length dimensions for Raised Face ANSI #300 and ISO 25 Flanged valves

⁽³⁾ Leq (Equivalent Pipe Length) refers to a fully opened valve with turbulent flow in new steel pipe schedule 40, values given for general consideration only

⁽⁴⁾ Kv/Cv values given for a fully opened valve

⁽⁵⁾ Exact dimensions for the trim envelope may vary with specific component positioning

Valve Code Designations

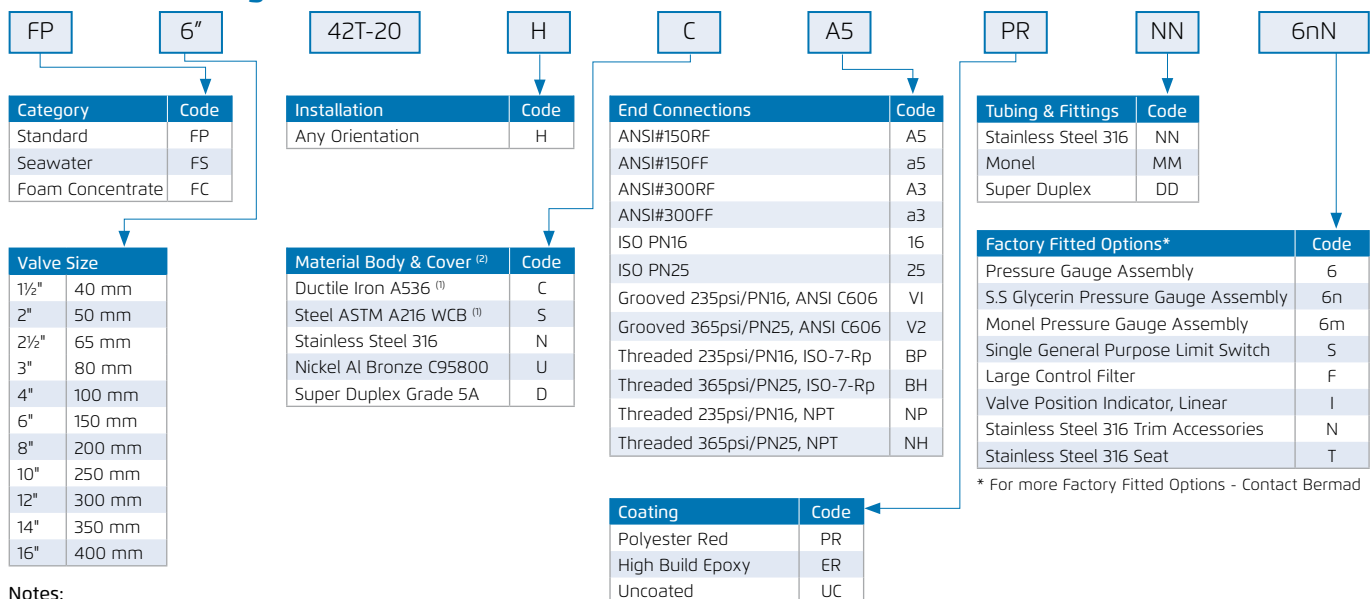

Notes: ⁽¹⁾ Coated internally & externally

⁽²⁾ Other materials available - see engineering data



www.bermad.com

The information contained herein may be changed by BERMAD without notice. BERMAD shall not be held liable for any errors. © Copyright 2010-2020 BERMAD CS Ltd. September 2020