



Pressure Relief Valve

Model 43T

The BERMAD model 43T is an elastomeric, pilot operated, pressure-relief valve. Designed specifically for advanced fire protection systems and the latest industry standards.

The 43T prevents damage from over-pressure in piping systems, maintaining a preset upstream pressure limit regardless of pressure peaks and fluctuating conditions.

Due to exceptional reliability and low head loss, it is ideal for relief of fire pump discharge. The 43T dependably relieves excess system pressure to sump or atmosphere, meeting all NFPA, UL, and FM requirements for fire pump service.

The 43T is also well-suited for maintaining foam concentrate discharge pressure for a balanced proportioning system.

As an option the 43T can be fitted with a valve position indicator that can include a limit switch suitable for Fire & Gas monitoring systems.

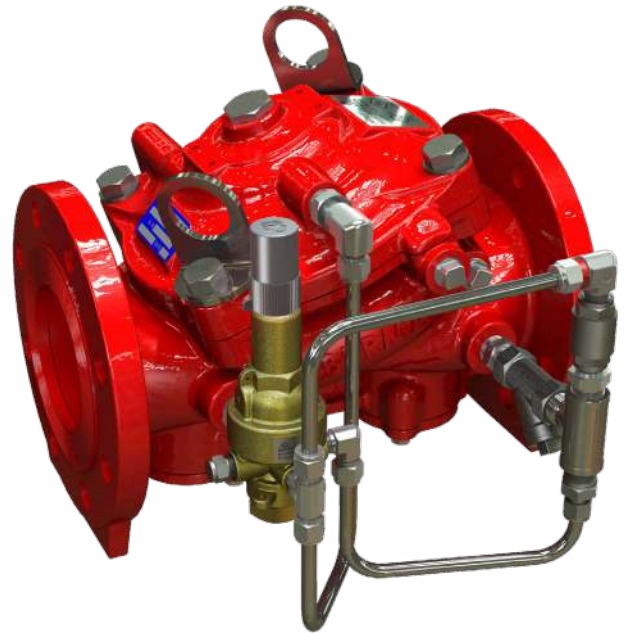

(for Illustration Only)

Benefits and Features

- **Safety and reliability**
 - Time-proven, simple, fail-safe actuation
 - Single piece, rugged, elastomeric diaphragm seal – VRSD technology
 - Obstacle-free, uninterrupted flow path
 - High discharge capacity
 - No mechanical moving parts
- **High performance**
 - Fast, smooth response to pressure fluctuations
 - High flow capacity
 - Approved for PN 25bar/365 psi
 - Straight-through-flow Y-type body
- **Specifically-designed for fire protection**
 - Face-to-face length standardized to ISO 5752, EN 558-1
 - Meets the requirements of the industry standards
- **Quick and easy maintenance**
 - In-line serviceable
 - Fast and easy cover removal

Typical Applications

- Fire pump pressure relief
- Foam concentrate recirculation
- Centralized thermal pressure relief
- Zonal safety relief

Approvals



UL-Listed
Fire Pump Relief Valves
Sizes 1½" -10"



FM Approved
Water Pressure Relief Valves
Sizes 1½" -10"



Det Norske Veritas
Type Approval



ABS
American Bureau of Shipping
Type Approval



Lloyd's Register
Type Approval

Additional Features

- Sea water compatibility
- Large control filter
- Position limit switches

BERMAD Fire Protection

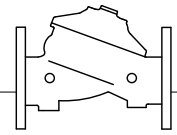

Model FP 400Y - 43T

400Y Series

Operation

(for Illustration Only)

8" valves and larger

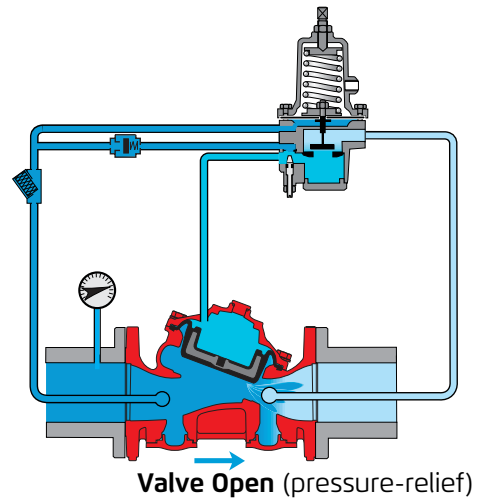
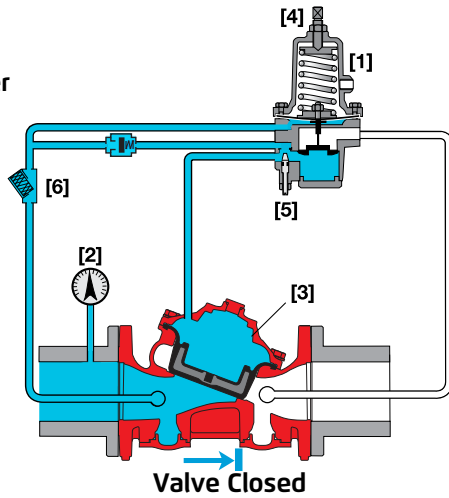

6" valves and smaller

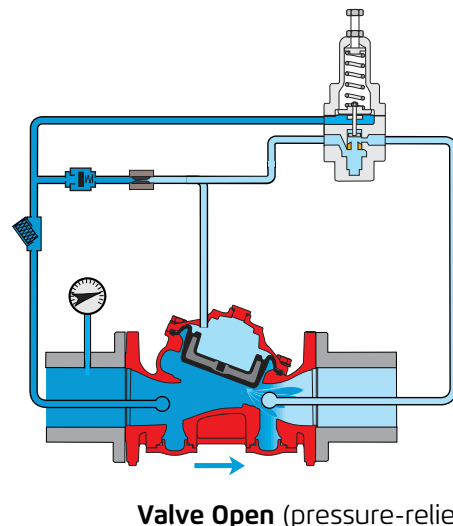
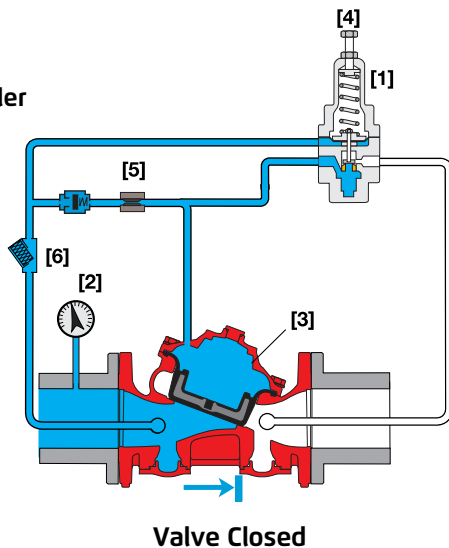

The BERMAD Model 43T pressure control valve remains closed as long as system pressure remains lower than the preset value. The preset pressure can be adjusted by way of the pilot adjusting screw [4]. When the pilot valve [1] senses upstream pressure [2] higher than the preset value it opens releasing water pressure from the main valve control chamber [3] thus causing the 43T to open and thereby relieving excess system pressure to a reservoir or sump, preventing system overpressure.

When inlet pressure falls, the pilot valve throttles, enabling pressure to accumulate in the control chamber. This causes the main valve to close further and sustain upstream pressure. An integral restrictor [5] controls the valve's closing speed. For valves 8" and larger, an adjustable needle valve is provided.

System P&ID

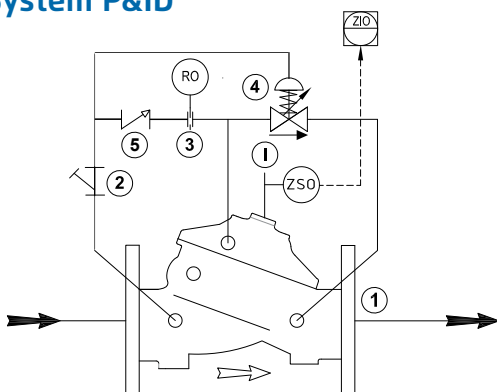

Components

- 1 BERMAD 400Y Water Control Valve
- 2 Y Strainer
- 3 Restriction Orifice
- 4 Pressure Relief Pilot Valve
- 5 Check Valve

Optional System Items

- ZS Limit Switch Assembly
- I Visual Indicator

See also Factory Fitted Options under the Valve Code Designations on the last page





System Installation

A typical installation of the BERMAD model 43T features a pilot valve for the automatic and accurate maintenance of a constant preset maximum upstream pressure, regardless of fluctuating demand. The fast opening 43T reliably relieves excess system pressure to sump or atmosphere, meeting NFPA, UL, and FM requirements for fire pump service. A unique actuator design ensures quick and smooth valve action.

Pressure reduction systems

- The fast response of the 43T preempts pressure reducing valve reaction preventing overpressure peak damage to sensitive equipment
- Backup/redundancy for reducing valve to ensure pressure zone rating at all times
- Thermal relief: Relieves overpressure caused by changes in temperature.

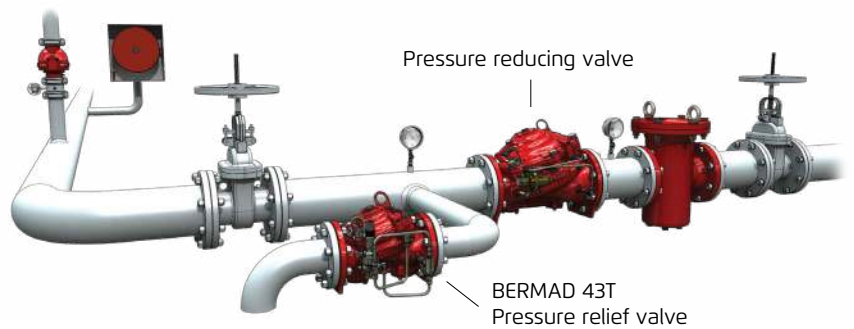

Recommended Relief Valve Sizing for pressure reducing systems

42T Pressure Reducing Valve Size in. (mm)	1½" (40)	2" (50)	2½" (65)	3" (80)	4" (100)	6" (150)	8" (200)	10" (250)	12" (300)	14" (350)	16" (400)
Recommended Relief valve size, in. (mm)	¾" (20)	¾" (20)	¾" (20)	¾" (20)	2" (50)	3" (80)	3" (80)	4" (100)	2 x 4" (2x100)	2 x 4" (2x100)	2 x 4" (2x100)

Fire pump relief

- Pressure relief for individual diesel fire pumps, in accordance with the NFPA 20 guidelines
- Suitable for a vertical turbine and horizontal fire pumps

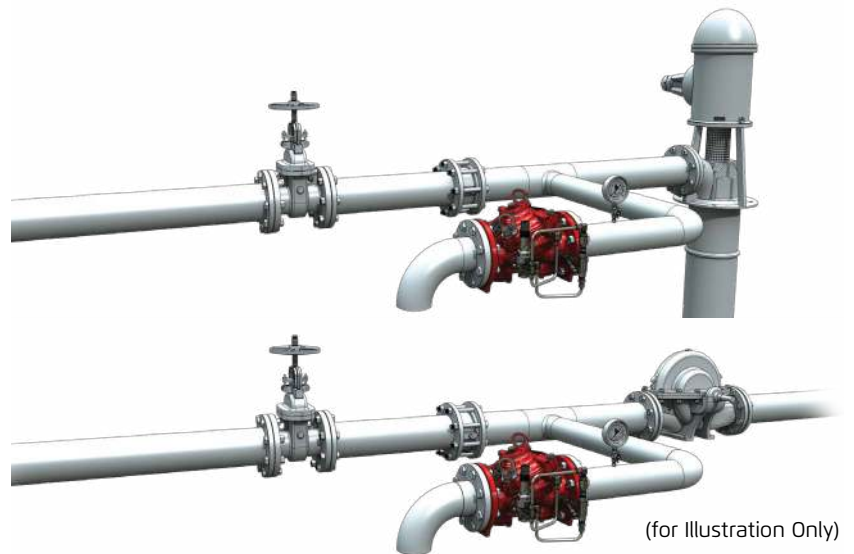

Engineering Specifications

The pressure relief valve shall maintain a constant, preset, maximum upstream pressure regardless of fluctuating demand, it shall be a UL-listed and FM-approved, 25 bar / 365 psi rated, line pressure driven and pilot operated, pressure control valve.

The valve shall be of the elastomeric-type with a straight-through Y-type body design. It shall have an unobstructed flow path, with no stem guide or supporting ribs.

Valve actuation shall be accomplished by a single-piece, rolling diaphragm bonded with a rugged radial seal disc.

The diaphragm assembly shall be the only moving part.

Removing the valve cover for inspection and maintenance shall be inline and shall not require removal of the control trim. The control trim shall be supplied pre-assembled and hydraulically tested by a factory certified to ISO 9000 and 9001 standards.

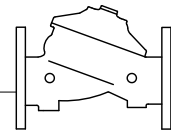

Technical Data

Available Sizes (inch)

- Flanged - 1½, 2, 3, 4, 6, 8, 10, 12, 14 & 16"
- Grooved - 1½, 2, 3, 4, 6 & 8"
- Threaded - 1½ & 2"

Pressure Rating

- ANSI#150 - 16 bar / 235 psi
- ANSI#300 - 1½" to 10" 25 bar / 365 psi
12" to 16" 20 bar / 300 psi
- Grooved/Threaded - Refer to code designations table below
- Pressure Settings: Class #150 / PN16: 4 – 16 bar (60 – 235 psi)
Class #300 / PN25: 7 – 25 bar (100 – 365 psi)

Maximum Differential for pump-relief valve or PSV:

25 bar/350 psi

Maximum Differential for PCV duty:

12 bar/175 psi

Pump relief sizing shall be in accordance with the NFPA 20 guidelines

Elastomer

- HTNR - Fabric Reinforced High Temperature Compound - See engineering data

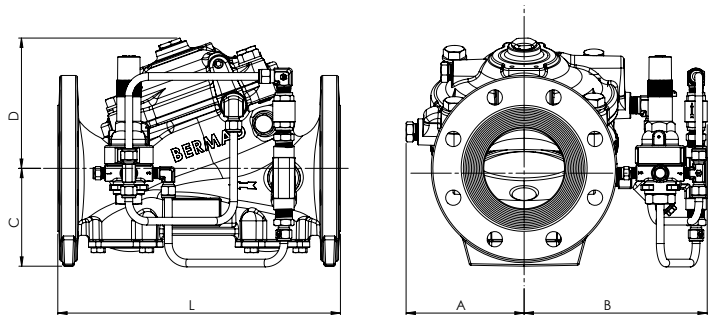

Valve Size	1½" DN40		2" DN50		2½" DN65		3" DN80		4" DN100		6" DN150		8" DN200		10" DN250		12" DN300		14" DN350		16" DN400		
	Unit	mm	in	mm	in	mm	in	mm	in	mm	in	mm	in	mm	in	mm	in	mm	in	mm	in	mm	in
L ⁽¹⁾		230	9.1	230	9.1	235	9.25	310	12.2	350	13.8	480	18.9	600	23.6	730	28.7	850	33.5	980	38.6	1100	43.3
L ⁽²⁾		230	9.1	238	9.4	241	9.37	326	12.8	368	14.5	506	19.9	626	24.6	730	28.7	888	35	980	38.6	1100	43.3
A		77.5	3	77.5	3	82	3.3	100	3.94	115	4.53	140	5.51	172	6.77	204	8	242	9.53	242	9.53	242	9.53
B		155	6.1	155	6.1	187	7.4	251	9.88	266	10.47	372	14.65	490	19.29	490	19.29	656	25.83	656	25.83	656	25.83
C		64	2.52	77	3.03	92	3.62	106	4.17	121	4.76	140	5.51	172	6.77	204	8.03	247	9.72	272	10.71	316	12.44
D		120	4.69	120	4.69	146	5.8	146	5.75	158	6.22	228	9	295	11.65	296	11.65	441	17.36	441	17.36	415	16.3
Kv / Cv ⁽⁴⁾		68 / 79		80 / 92		105 / 121		190 / 219		345 / 398		790 / 912		1160 / 1340		1355 / 1565		2370 / 2737		2850 / 3292		3254 / 3758	
Leq ⁽³⁾ : m/ft		2 / 7		4 / 14		9 / 31		7 / 23		9 / 30		15 / 49		27 / 89		62 / 203		52 / 171		59 / 194		88 / 289	
Kg/lb flanged#150/ISO16		17.9 / 39.4		19.3 / 42.5		23 / 50		34 / 74.8		44 / 95.8		87.3 / 192		150 / 331		180 / 397		323 / 712		356 / 784		403 / 886	

Notes: ⁽¹⁾ Refers to the length dimensions for Raised Face ANSI #150, ISO 16 Flanged, Threaded and Grooved valves

⁽²⁾ Refers to the length dimensions for Raised Face ANSI #300 and ISO 25 Flanged valves

⁽³⁾ Leq (Equivalent Pipe Length) refers to a fully opened valve with turbulent flow in new steel pipe schedule 40, values given for general consideration only

⁽⁴⁾ Kv/Cv values given for a fully opened valve

⁽⁵⁾ Exact dimensions for the trim envelope may vary with specific component positioning

Valve Code Designations

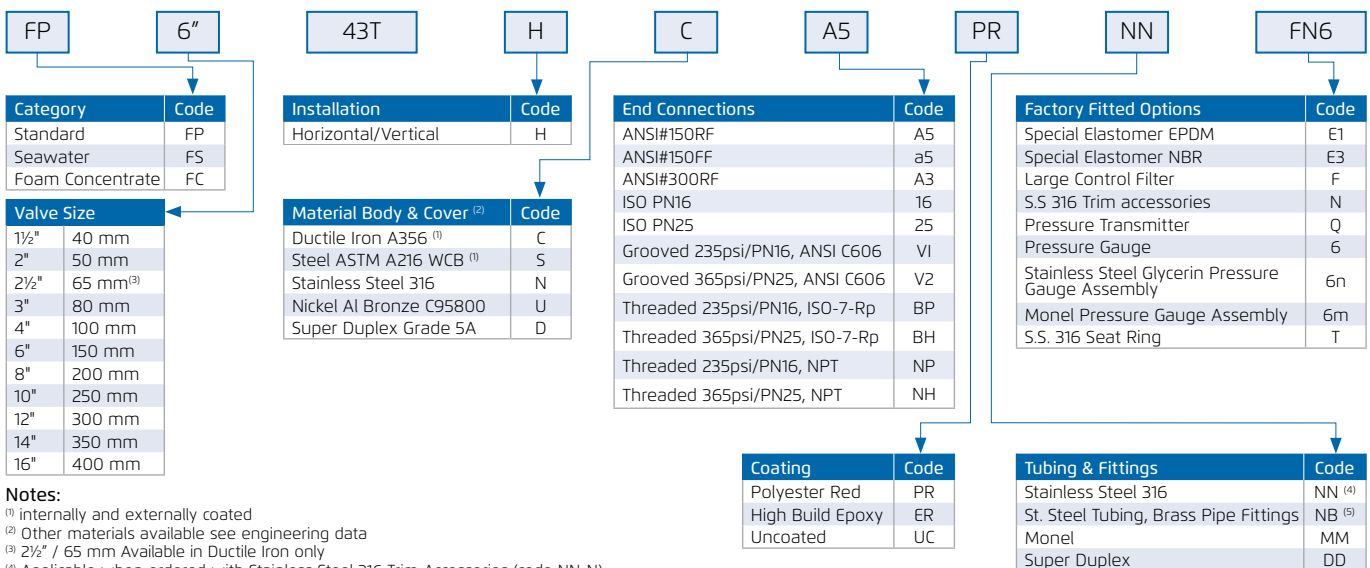

Notes:

⁽¹⁾ Internally and externally coated

⁽²⁾ Other materials available see engineering data

⁽³⁾ 2½" / 65 mm Available in Ductile Iron only

⁽⁴⁾ Applicable when ordered with Stainless Steel 316 Trim Accessories (code NN-N)

⁽⁵⁾ Manufacturers Standard: St. Steel 316 Tubing and Tube Fittings, Brass Pipe Fittings and Brass/Bronze Pilot Valve & Accessories

