

## Pressure Reducing Valve

**Model: BC-720-P** (Sizes 1.5"- 8"; DN40-200)

### Description

Hydraulically operated, diaphragm actuated pressure reducing control valve that reduces a high upstream pressure to a lower constant downstream pressure, regardless of fluctuating demand or varying upstream pressure.

### Installation

1. Ensure enough space around the valve assembly for future maintenance and adjustments
2. Prior to valve installation, flush the pipeline to ensure a flow of clean fluid through the valve.
3. After flushing ensure that the main strainer and the control loop filter are clean.
4. For future maintenance, install Isolation Valves upstream and downstream of the control valve
5. Install the valve in the pipeline with the valve flow direction arrow in the actual flow direction. When applicable use the lifting ring provided on the valve cover for installing the valve
6. For best performance, it is recommended to install the valve horizontally and upright. For different valve positions – consult Bermad
7. After installation carefully inspect/correct any damaged accessories, piping, tubing, or fittings.
8. Install a pressure gauge downstream of the valve or on the pilot.
9. It is highly recommended to install a Bermad strainer (model 70F) upstream of the control valve, to prevent debris from damaging the valve's operation
10. Install a pressure relief valve Bermad model 73Q for protection against momentary pressure peaks.

### Commissioning & Calibration

[Visit our YouTube page for a short commissioning instruction video of the BC-720-P](#)

1. Verify that you have typical upstream pressure.
2. Confirm that cock valves [1], [2] & [3] are open (handle parallel to cock-valve body), and open all service valves on the pressure gauges.
3. The pressure reducing valve pilot [2PB-L] will have been calibrated at the factory and the set pressure will be indicated on the pilot cover. If the pilot set pressure is not compatible with your requirements, then the pilots need to be reset.
4. If the pilot needs to be reset then loosen the pilots adjustment screw locking nut and release the adjustment screw turning it counter-clockwise until it is completely loose.
5. Slowly fully open the upstream isolating valve and partially the downstream isolating valve, to fill-up, in a slow and controlled manner the consumers line downstream from the pressure reducing system. Confirm that the supply pressure and the flow through the system are typical. If necessary create flow by opening a hydrant, or reduce the flow by adjusting the downstream isolating valve
  - 5.1. If the pilot adjustment screw has been loosened in preparation for resetting, the valve will close shortly after opening the upstream isolation valve. Ignore line 6 and continue from line 7.
6. Vent air from the valve's control loop by loosening cover tube fitting at the highest point, allowing all air to bleed. Retighten the tube fitting eyebolt. The BC-720-P pressure reducing valve is now operational and in service, don't forget to open fully all isolating valves on the main line.
7. If the set pressure is either different from the design or the requirements have been changed. The valve will need to be readjusted
  - 7.1. After the pilot adjustment screw has been released according to line 3.1, slowly turn the pilot adjusting screw clockwise to increase downstream pressure until the required pressure is reached.
  - 7.2. Allow the 720 main valve to react and the pressure to stabilize. When the correct pressure is confirmed retighten the adjustment screw locking nut.
  - 7.3. Vent air from the valve's control loop by loosening a cover tube fitting at the highest point, allowing all air to bleed. Retighten the tube fitting eyebolt.
8. Fully open the downstream isolation valve whilst verifying continued correct downstream pressure
9. The BC-720-P pressure reducing valve is now operational and in service
10. Relief Valves if fitted should be set 1 bar above system highest set-pressure

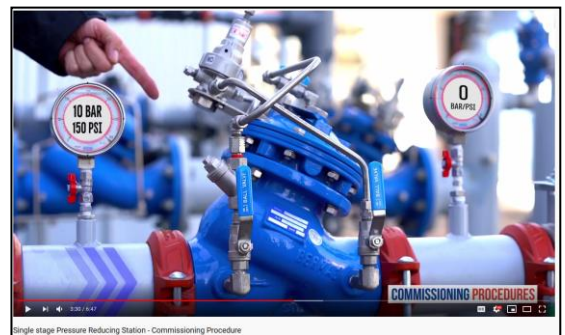

[www.bermad.com](http://www.bermad.com)

The information contained herein may be changed by Bermad without notice. Bermad shall not be held liable for any errors.  
© Copyright 2007-2017 Bermad CS Ltd.

**Trouble-Shooting**

11. **Valve fails to Open:** Check for sufficient inlet pressure & check cock valves status.
12. **Valve fails to Close:** Check cock valves status, clean control filter [4] & detect for clogged ports or fittings, check for debris trapped in the main valve, and confirm that the diaphragm is not leaking.
13. **Valve fails or Regulates Erratically:** Check cock valves status, release air trapped in the valves control chamber, clean filters, check for debris caught in the valve passage.

**Preventative Maintenance**

1. System operating conditions and water quality will affect the valve and should be checked periodically to determine the required interval for preventative maintenance. The schedule below assumes good conditions and should be considered a minimum requirement.
2. Maintenance instructions:
  - 2.1.1. Tools required:
    - 2.1.1.1. Metric and imperial wrenches
    - 2.1.1.2. Anti seize grease
  - 2.2. Weekly:
    - 2.2.1. Visual inspection to locate leaks and external damages
    - 2.2.2. Check pressure gauge read correct pressures
  - 2.3. Yearly:
    - 2.3.1. Close isolating valves and clean strainer and control loop filters.
    - 2.3.2. Perform a functional test including a closing test to verify valve sealing.
  - 2.4. 3 – 5 Yearly:
    - 2.4.1. Inspect the internal condition of the valve.
    - 2.4.2. Open the stud nuts and remove the actuator as one unit from the valve body. Disassemble necessary control tubes
  - 2.5. Disassemble the actuator and examine its parts carefully for signs of wear, corrosion, or any other abnormal conditions
  - 2.6. Replace worn parts and all the Elastomers. Lubricate the bolts and studs threads with Anti seize grease.
3. It is highly recommended to stock a reserve actuator assembly for each size. This allows minimal field work and system downtime

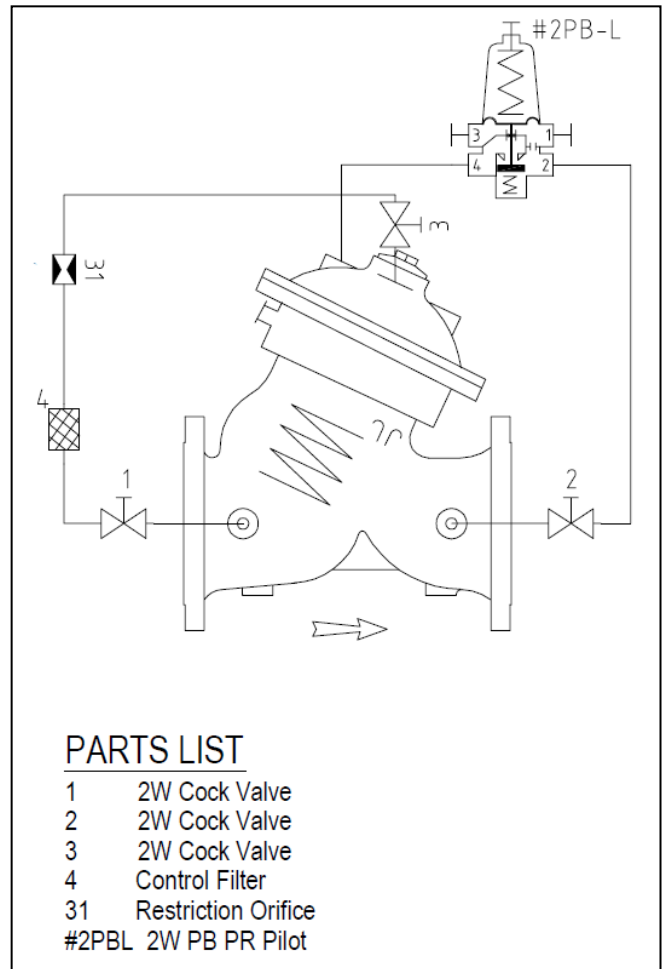

**Spare parts**

Bermad has a convenient and easy to use ordering guide for valve spare-parts and control system components at

<http://www.bermad.com/downloads>

For solenoid valves refer to model and S/N on solenoid tags.

Pub # : IOM_BC-720-P	By: NS 09/19	Rev:	File name: IOM_BC-720-P
----------------------	--------------	------	-------------------------



[www.bermad.com](http://www.bermad.com)

The information contained herein may be changed by Bermad without notice. Bermad shall not be held liable for any errors.  
© Copyright 2007-2017 Bermad CS Ltd.