

# HYDRAULIC VALVE, DOUBLE CHAMBER

## Model IR-100-DC-Z

The BERMAD Model IR-100-DC-Z Hydraulic Control Valve is a hydraulically operated, diaphragm actuated control valve that opens and shuts in response to a local or remote pressure command.

The valve comprises two major components: the body and the actuator assembly. The actuator assembly is removable from the body as an integral unit. It consists of both upper and lower control chambers, providing Isolated and protected diaphragm.

The double chambered valve operation is independent of valve differential pressure. This develops maximum power, ensuring immediate valve response combined with inherent soft closing

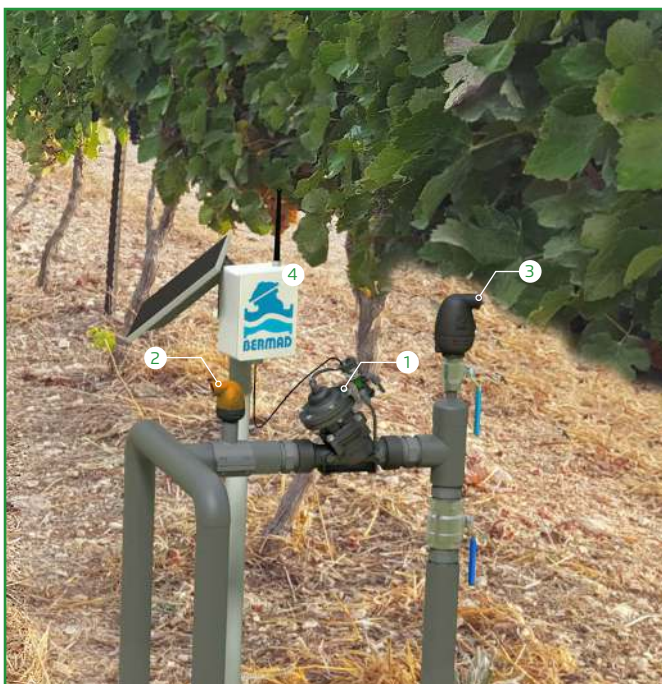

- [1] BERMAD Model IR-100-DC-Z Open upon to local manual command
- [2] BERMAD Kinetic Air Valve Model IR-K10
- [3] BERMAD Combination Air Valve Model IR-C10
- [4] BERMAD RF RTU Battery Operated with Solar Kit

### Features & Benefits

- Hydraulic Control Valve with On/Off feature.
  - Line Pressure Driven
  - Suitable also for remote and/or elevated systems
- Double chamber design
  - Full powered opening and closing
  - Non-slam closing characteristic
  - Protected diaphragm
- Engineered Plastic Valve with Industrial Grade Design
  - hYflow 'Y' Valve Body with "Look Through" Design
  - Ultra-high flow capacity - Low pressure loss User-Friendly Design
- User Friendly Design
  - Simple in-line inspection and service, Easy maintenance
  - Simple in-line conversion from single to double chamber

### Typical Applications

- Computerized Irrigation Systems
- Drip Systems
- Sprinklers & Micro-Sprinklers
- Greenhouses Irrigation
- Low Pressure Systems
- End-line Flushing (Distribution Line, Irrigation Machine) - "Flush-'n-Stop"
- Proportional Pressure Reducing
- Non-slam Closing (or moderate closing)
- Active Double Chambered (B) - full Powered Opening & Closing

### Operation:

Hydraulic Command ① is applied to the Control Chamber ② through the Manual Selector ③. This creates superior closing force that moves the Diaphragm Assembly ④ to a closed position. Discharging the pressure in the upper control chamber to atmosphere, causes the line pressure acting on the seal disk to move the valve to the open position.

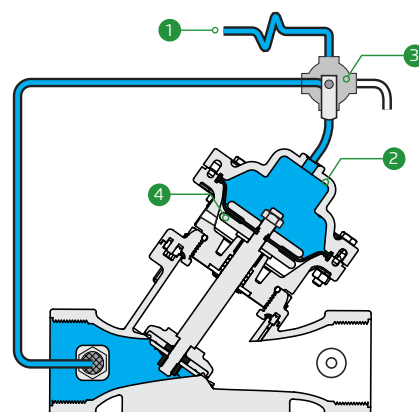

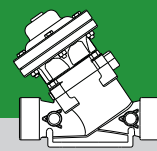

### IR-100-DC-Z

### Technical Data

**Pressure Rating:**

10 bar; 145 psi

**Operating Pressure Range:**

0.5-10 bar; 7-145 psi

**Materials:**

**Body, Cover and Plug:**  
Polyamid 6 & 30% GF

**Diaphragm:**  
NR, Nylon fabric reinforced

**Seals:** NR

**Spring:** Stainless Steel

**Cover Bolts:** Stainless Steel

**Actuator:**  
Composite Material &  
Stainless Steel

**Control Accessories:**

**Tubing and Fittings:**  
Polyethylene

### Technical Specifications

#### Y Pattern Valves Dimensions & Weights

For [BERMAD](#) angle, dual & T pattern,  
Please see our full engineering page.

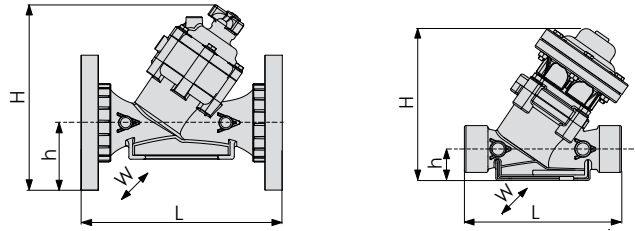

Size Inch; DN	1½"; 40	2"; 50	2"; 50	2"L; 50L	2½"; 50L	3"; 80	3"; 80		3"L; 80L		4"; 100		
End Connections	Rc (BSP.T), NPT	G (BSP.F)	Rc (BSP.T), NPT	Rc (BSP.T), NPT	G (BSP.F)	Rc (BSP.T), NPT	Universal Flanges		Rc 3 (BSP.T)	Universal Flanges		Universal Flanges	
							Metal	Plastic	3" NPT	Metal	Plastic	Metal	Plastic
L (mm)	200	200	230	230	230	298	308	308	298	308	308	350	350
H (mm)	194	196	196	220	220	232	277	277	356	395	395	407	407
h (mm)	40	40	40	43	43	55	100	100	60	100	100	112	112
W (mm)	126	126	126	135	135	135	200	200	210	210	210	224	224
CCDV (lit)	0.13	0.13	0.13	0.17	0.17	0.17	0.17	0.17	0.55	0.55	0.55	0.55	0.55
Weight (Kg)	1.7	1.7	1.7	2.2	2.2	2.3	5.1	3.2	5.95	7.35	6.45	9.45	7.55

CCDV = Control Chamber Displacement Volume • **BSP.T** = Internal Threaded • **BSP.F** = External Threaded

• Other End Connections are available on request. For dimensions and weights of adapters or valve with adapters please consult with customer service

### Flow Properties

Sizes	Inch DN	1½"	2"	2L"	2½"	3"	3"L	4"
		40	50	50L	65	80	80L	100
KV		50	50	100	100	100	200*	200*

### Valve Flow Coefficient

$$\Delta P = \left( \frac{Q}{Kv} \right)^2$$

$Kv = m^3/h @ \Delta P \text{ of } 1 \text{ bar}$   
 $Q = m^3/h$   
 $\Delta P = \text{bar}$

### Flow Chart

