

# SOLENOID CONTROL VALVE, DOUBLE CHAMBER

## IR-110-DC-3W-X

The BERMAD Model IR-110-DC-X Solenoid Controlled Valve is a double chambered, hydraulically operated, diaphragm actuated control valve that opens and closes drip-tight in response to an electric signal.

The valve comprises two major components: the body and the actuator assembly. The actuator assembly is removable from the body as an integral unit. It consists of both upper and lower control chambers, providing Isolated and protected diaphragm

The double chambered valve operation is independent of valve differential pressure. This develops maximum power, ensuring immediate valve response combined with inherent soft closing



**[1]** BERMAD Model IR-110-DC-3W-X Opens in response to electric signal

**[2]** BERMAD Kinetic Air Valve Model IR-K10

**[3]** BERMAD Combination Air Valve Model IR-C10

**[4]** BERMAD RF RTU Battery Operated with Solar Kit

### Operation:

Line Pressure **1** is applied to the Control Chamber **2**, through the opened 3-Way Solenoid **3**. This creates superior closing force that moves the Diaphragm Assembly **4** to a closed position. Energizing the Solenoid causes it to switch, discharging pressure from the control chamber and thereby opening the main Valve.

### Features & Benefits

- Hydraulic Control Valve with Solenoid Control.
  - Line Pressure Driven .
  - Electrically controlled On/Off.
  - Suitable also for remote and/or elevated systems
- Double chamber design
  - Full powered opening and closing.
  - Non-slam closing characteristic.
  - Protected diaphragm
- Engineered Plastic Valve with Industrial Grade Design
  - hYflow 'Y' Valve Body with "Look Through" Design.
  - Ultra-high flow capacity - Low pressure loss
- User-Friendly Design
  - Simple in-line inspection and service. Easy maintenance
  - Simple in-line conversion from single to double chamber

### Typical Applications

- Computerized Irrigation Systems
- Drip Systems
- Sprinklers & Micro-Sprinklers
- Greenhouses Irrigation
- Low Pressure Systems
- End-line Flushing (Distribution Line, Irrigation Machine) - "Flush-'n-Stop"
- Proportional Pressure Reducing
- Non-slam Closing (or moderate closing)
- Active Double Chambered (B) - full Powered Opening & Closing

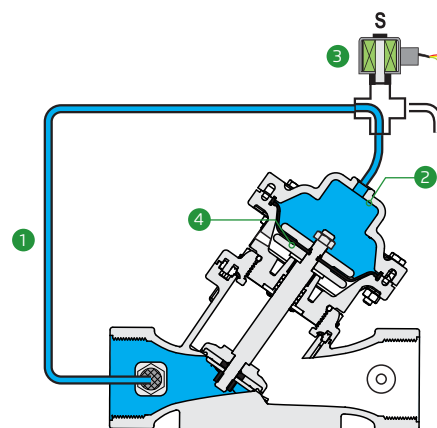

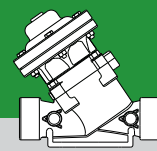

## IR-110-DC-3W-X

### Technical Data

**Pressure Rating:**  
10 bar; 145 psi

**Operating Pressure Range:**  
0.5-10 bar; 7-145 psi

### Materials:

**Body, Cover and Plug:**  
Polyamid 6 & 30% GF

**Diaphragm:**  
NR, Nylon fabric reinforced

**Seals:** NR

**Spring:** Stainless Steel

**Cover Bolts:** Stainless Steel

**Actuator:**  
Composite Material &  
Stainless Steel

### Control Accessories:

**Tubing and Fittings:**  
Polyethylene

### Solenoid Voltage Range:

**S-390 & S-400:**  
24 VAC, 24 VDC

**S-392 & S-402:**  
9-20 VDC, Latch

**S-982 & S-985:**  
12-50 VDC, Latch

**Other Voltages available**

### Technical Specifications

#### Y Pattern Valves Dimensions & Weights

For [BERMAD](#) angle, dual & T pattern,  
Please see our full engineering page.

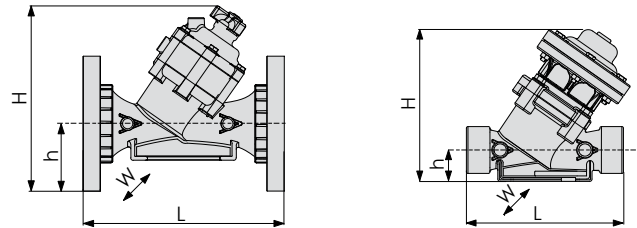

Size Inch; DN	1½"; 40	2"; 50	2"; 50	2"L; 50L	2½"; 50L	3"; 80	3"; 80		3"L; 80L		4"; 100		
End Connections	Rc (BSP.T), NPT	G (BSP.F)	Rc (BSP.T), NPT	Rc (BSP.T), NPT	G (BSP.F)	Rc (BSP.T), NPT	Universal Flanges		Rc 3 (BSP.T)	Universal Flanges		Universal Flanges	
							Metal	Plastic	3" NPT	Metal	Plastic	Metal	Plastic
L (mm)	200	200	230	230	230	298	308	308	338	343	343	364	364
H (mm)	194	196	196	220	220	232	277	277	356	395	395	407	407
h (mm)	40	40	40	43	43	55	100	100	60	100	100	112	112
W (mm)	126	126	126	135	135	135	200	200	210	210	210	224	224
CCDV (lit)	0.13	0.13	0.13	0.17	0.17	0.17	0.17	0.17	0.55	0.55	0.55	0.55	0.55
Weight (Kg)	1.7	1.7	1.7	2.2	2.2	2.3	5.1	3.2	5.95	7.35	6.45	9.45	7.55

CCDV = Control Chamber Displacement Volume • BSP.T = Internal Threaded • BSP.F = External Threaded

• Other End Connections are available on request. For dimensions and weights of adapters or valve with adapters please consult with customer service

### Flow Properties

Sizes	Inch DN	1½"	2"	2L"	2½"	3"	3"L	4"
		40	50	50L	65	80	80L	100
KV		50	50	100	100	100	168	168

### Valve Flow Coefficient

$$\Delta P = \left( \frac{Q}{Kv} \right)^2$$

$Kv = m^3/h @ \Delta P \text{ of } 1 \text{ bar}$   
 $Q = m^3/h$   
 $\Delta P = \text{bar}$

### Flow Chart

