



# PRESSURE REDUCING VALVE

## Model IR-120-3W-XZ

The BERMAD Pressure Reducing Valve is a hydraulically operated, diaphragm actuated control valve that reduces higher upstream pressure to lower constant downstream pressure and opens fully upon line pressure drop.



**[1]** BERMAD Model IR-120-XZ establishes reduced pressure zone, protecting laterals and distribution line.

**[2]** Kinetic Air Valve

**[3]** Combination Air Valve

### Features and Benefits

- Line pressure driven Hydraulic Level Control
  - Protects downstream systems
  - Opens fully upon line pressure drop
- Engineered Plastic Valve with Industrial Grade Design
  - Adaptable on-site to a wide range of end connection sizes and types
  - Articulated flange connections isolate valve from line bending and pressure stresses
  - Highly durable, chemical & cavitation resistant
- hYflow 'Y' Valve Body with "Look Through" Design
  - Ultra-high flow capacity at Low pressure loss
- Unitized Flexible Super Travel Diaphragm with a Guided Plug
  - Accurate and stable regulation with smooth closing
  - Requires low actuation pressure
  - Prevents diaphragm erosion and distortion
  - Simple In-Line Inspection and Service

### Typical Applications

- Computerized Irrigation Systems
- Pressure Reducing Stations
- Systems Subject to Varying Supply Pressure
- Distribution Centers
- Energy Saving Irrigation Systems

### Operation:

The Pressure Reducing Pilot **1** commands the main Valve to throttle closed should Downstream Pressure **P2** rise above pilot setting, and to open fully when it drops below pilot setting. The Manual Selector **2** enables local manual closing.

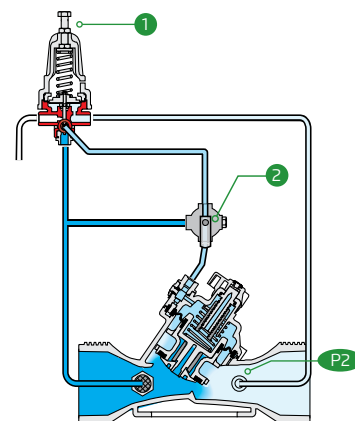



**IR-120-3W-XZ**

**Technical Data**

**Pressure Rating:**  
10 bar; 145 psi

**Operating Pressure Range:**  
0.5-10 bar; 7-145 psi

**Setting Range:**  
1-7 bar; 15-100 psi

Setting ranges vary according to specific pilot spring. Please consult factory

**Materials:**

**Body, Cover and Plug:**  
Glass-Filled Nylon

**Diaphragm:**  
NR, Nylon fabric reinforced

**Seals:** NR

**Spring:** Stainless Steel

**Cover Bolts:** Stainless Steel

**Control Accessories:**

**Tubing and Fittings:**  
Plastic

**Pilot Spring Range:**

Spring	Spring color	Setting Range
J	Green	0.2-1.7 bar
K	Gray	0.5-3.0 bar
N	Colorless	0.8-6.5 bar

**Technical Specifications**

**Y Pattern Valves Dimensions & Weights**

For [BERMAD](#) angle, dual & T pattern, Please see our full engineering page.

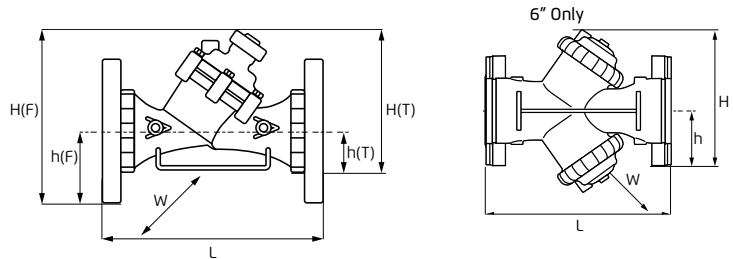

Sizes Inch ; DN	1½" ; 40	2" ; 50		2"L ; 50	2½" ; 65	Rc (BSP.T), NPT	3" ; 80	
End Connections	Rc (BSP.T), NPT	Rc (BSP.T), NPT	G (BSP.F)	Rc (BSP.T), NPT	G (BSP.F)	Rc (BSP.T), NPT	Universal Flanges	
							Metal	Plastic
L (mm)	200	230	230	230	230	298	308	308
H (F) (mm)	—	—	—	—	—	—	244	244
H (T) (mm)	173	173	173	187	187	199	—	—
h (F) (mm)	—	—	—	—	—	—	100	100
h (T) (mm)	40	40	40	43	43	55	—	—
W (mm)	97	97	97	135	135	135	200	200
CCDV (lit)	0.12	0.12	0.12	0.15	0.15	0.15	0.15	0.15
Weight (kg)	1.1	1.2	1.2	1.47	1.47	1.6	4.4	2.5

Sizes Inch ; DN	3"L ; 80L		4" ; 100		4"L ; 100L		Groove	6"R ; 150R	6" ; 150	6" ; 150	
End Connections	Rc (BSP.T), NPT	Universal Flanges		Universal Flanges		Universal Flanges		Universal Flanges	Groove	Universal Flanges	
		Metal	Plastic	Metal	Plastic	Metal	Plastic	Metal		Plastic	
L (mm)	298	308	308	350	350	442	442	400	470	480	504
H (F) (mm)	—	317	317	329	329	340	340	286	377	198	286
H (T) (mm)	278	—	—	—	—	—	—	—	—	—	—
h (F) (mm)	—	100	100	112	112	112	112	57	149	100	143
h (T) (mm)	60	—	—	—	—	—	—	—	—	—	—
W (mm)	168	200	200	224	224	226	226	226	287	475	475
CCDV (lit)	0.62	0.62	0.62	0.62	0.62	1.15	1.15	1.15	1.15	2 x 0.62	2 x 0.62
Weight (kg)	3	4.6	3.7	7.4	4.6	13.5	10	8	16.5	11	12.5

CCDV = Control Chamber Displacement Volume • **BSP.T** = Internal Threaded • **BSP.F** = External Threaded • Other End Connections are available on request. For dimensions and weights of adapters or valve with adapters please consult with customer service

**Flow Properties**

Sizes Inch DN	1½" 40	2" 50	2"L 50L	2½" 65
KV	50	50	100	100

Sizes Inch DN	3" 80	3"L 80L	4" 100	4"L 100L	6" R 150L	6" 150
KV	100	200	200	340	340	400

**Valve Flow Coefficient**

$$\Delta P = \left( \frac{Q}{Kv} \right)^2$$

$Kv = m^3/h @ \Delta P \text{ of } 1 \text{ bar}$   
 $Q = m^3/h$   
 $\Delta P = \text{bar}$

**Flow Chart**

