

PRESSURE REDUCING VALVE, DOUBLE CHAMBER

Model IR-120-DC-3W-XZ

The BERMAD Model IR-120-DC-3W-XZ Pressure Reducing Valve is a double chambered, hydraulically operated, diaphragm actuated control valve that reduces higher upstream pressure to lower constant downstream pressure and opens fully upon line pressure drop. The valve comprises two major components: The body and the actuator assembly. The actuator assembly consists of both an upper and a lower control chamber.

The double chambered valve operation is independent of valve differential pressure. This develops maximum power, ensuring immediate valve response combined with inherent soft closing.



- [1] BERMAD Model IR-120-DC-3W-XZ reduces the supply pressure to preset pressure, protecting the system
- [2] BERMAD Solenoid Control Valves Model IR-210
- [3] BERMAD Combination Air Valve Model IR-C10
- [4] BERMAD Kinetic Air Valve Model IR-K10
- [5] BERMAD RF RTU Battery Operated with Solar Kit

Features & Benefits

- Line pressure driven, Hydraulically Controlled
 - Protects downstream systems
 - Opens fully upon line pressure drop
- Double chamber
 - Full powered opening and closing
 - Decreased pressure loss
 - Low throttling noise
 - Non-slam closing characteristic
 - Protected diaphragm
- Engineered Plastic Valve with Industrial Grade Design
- hYflow 'Y' Valve Body with "Look Through" Design
 - Ultra-high flow capacity - Low pressure loss
- User-Friendly Design
 - Simple in-line inspection and service

Typical Applications

- Pressure Reducing Stations
- Systems Subject to Varying Supply Pressure
- Energy Saving Irrigation Systems

Operation:

The Pressure Reducing Pilot ① commands the main Valve to throttle closed should Downstream Pressure P_2 rise above pilot setting, and to open fully when it drops below pilot setting. The Manual Selector ② enables local manual closing.

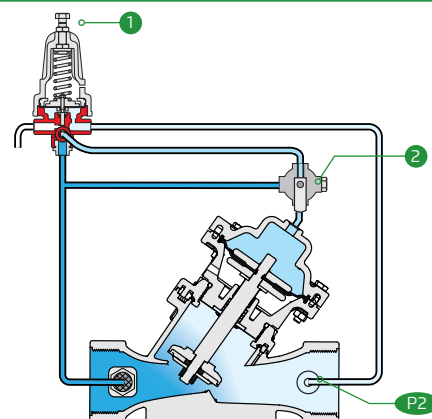

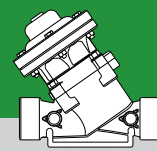

IR-120-DC-3W-XZ

Technical Data

Pressure Rating:

10 bar; 145 psi

Operating Pressure Range:

0.5-10 bar; 7-145 psi

Setting Range:

1-7 bar; 15-100 psi

Setting ranges vary according to specific pilot spring. Please consult factory

Materials:

Body, Cover and Plug:
Polyamid 6 & 30% GF

Diaphragm:
NR, Nylon fabric reinforced

Seals: NR

Spring: Stainless Steel

Cover Bolts: Stainless Steel

Actuator:
Composite Material & Stainless Steel

Control Accessories:

Tubing and Fittings:
Polyethylene

Pilot Spring Range:

Spring	Spring color	Setting Range
J	Green	0.2-1.7 bar
K	Gray	0.5-3.0 bar
N	Colorless	0.8-6.5 bar

Technical Specifications

Y Pattern Valves Dimensions & Weights

For [BERMAD](#) angle, dual & T pattern, Please see our full engineering page.

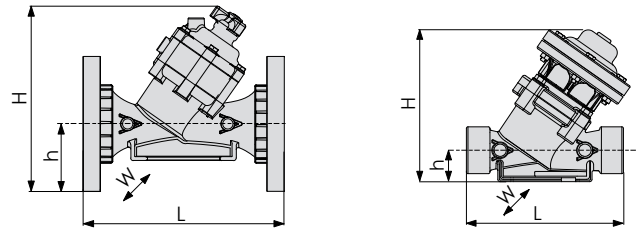

Size Inch; DN	1½"; 40	2"; 50	2"; 50	2"L; 50L	2½"; 50L	3"; 80	3"; 80	3"; 80	3"L; 80L	4"; 100			
End Connections	Rc (BSP.T), NPT	G (BSP.F)	Rc (BSP.T), NPT	Rc (BSP.T), NPT	G (BSP.F)	Rc (BSP.T), NPT	Universal Flanges		Rc 3 (BSP.T)	Universal Flanges			
							Metal	Plastic	3" NPT	Metal	Plastic	Metal	Plastic
L (mm)	200	200	230	230	230	298	308	308	298	308	308	350	350
H (mm)	194	196	196	220	220	232	277	277	356	395	395	407	407
h (mm)	40	40	40	43	43	55	100	100	60	100	100	112	112
W (mm)	126	126	126	135	135	135	200	200	210	210	210	224	224
CCDV (lit)	0.13	0.13	0.13	0.17	0.17	0.17	0.17	0.17	0.55	0.55	0.55	0.55	0.55
Weight (Kg)	1.7	1.7	1.7	2.2	2.2	2.3	5.1	3.2	5.95	7.35	6.45	9.45	7.55

CCDV = Control Chamber Displacement Volume • **BSP.T** = Internal Threaded • **BSP.F** = External Threaded

• Other End Connections are available on request. For dimensions and weights of adapters or valve with adapters please consult with customer service

Flow Properties

Sizes	Inch DN	1½"	2"	2L"	2½"	3"	3"L	4"
		40	50	50L	65	80	80L	100
KV		50	50	100	100	100	200*	200*

Valve Flow Coefficient

$$\Delta P = \left(\frac{Q}{Kv} \right)^2$$

$Kv = m^3/h @ \Delta P \text{ of } 1 \text{ bar}$
 $Q = m^3/h$
 $\Delta P = \text{bar}$

Flow Chart

