

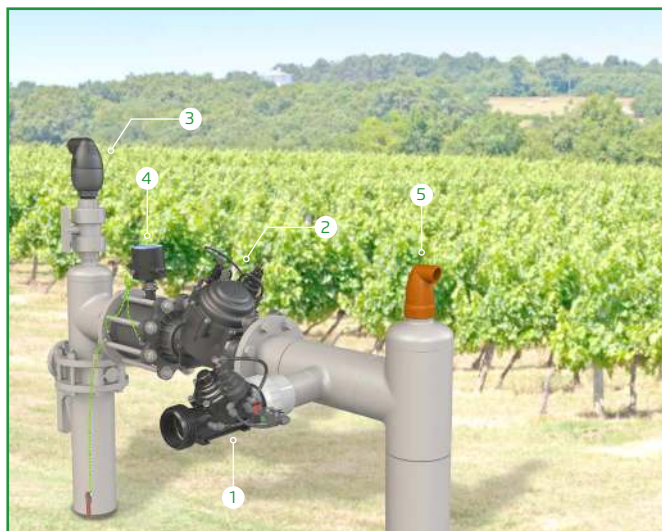

QUICK PRESSURE RELIEF VALVE

Model IR-13Q

The BERMAD Model IR-13Q is a hydraulically operated, diaphragm actuated control valve designed to relieve excessive line pressure when it rises above the preset maximum. It responds to rises in system pressure immediately, accurately and with high repeatability, by opening fully. The BERMAD Model IR-13Q provides smooth drip tight closing.



- [1] BERMAD Model IR-13Q protects system from pressure spikes
- [2] Pressure Reducing Valve
- [3] Combination Air Valve
- [4] Electromagnetic Water Meter
- [5] Kinetic Air Valve

Features and Benefits

- Hydraulic Control Valve
 - Line pressure driven
 - Short response time
 - Long term drip tight sealing
- Engineered Plastic Valve with Industrial Grade Design
 - Adaptable on-site to a wide range of end connection sizes and types
 - Highly durable, chemical & cavitation resistant
- hYflow 'Y' Valve Body with "Look Through" Design
 - Ultra-high flow capacity at Low pressure loss
- Unitized Flexible Super Travel Diaphragm with a Guided Plug
 - Accurate and stable regulation with smooth closing
 - Requires low actuation pressure
 - Prevents diaphragm erosion and distortion
 - Simple In-Line Inspection and Service

Typical Applications

- System Burst Protection
- Momentary Pressure Peak Elimination
- System Failure Visual Indication
- Filter Burst Protection

Operation:

The Pressure Relief Pilot ① commands the valve to open immediately should the upstream pressure **P1** abruptly rise above pilot setting, and to close smoothly when it falls below pilot setting, sealing drip tight. The Cock Valve ② enables manual operating test.

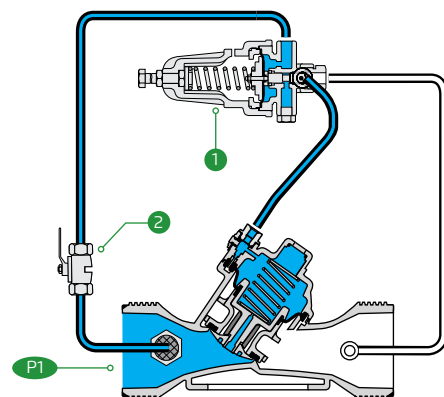



IR-13Q

Technical Data

Pressure Rating:
10 bar; 145 psi

Operating Pressure Range:
0.5-10 bar; 7-145 psi

Setting Range:
1-7 bar; 15-100 psi

Setting ranges vary according to specific pilot spring. Please consult factory

Materials:
Body, Cover and Plug:
Polyamid 6 & 30% GF

Diaphragm:
NR, Nylon fabric reinforced

Seals: NR

Spring: Stainless Steel

Cover Bolts: Stainless Steel

Control Accessories:

Tubing and Fittings:
Plastic

Pilot Spring Range:

Spring	Spring color	Setting Range
V	Blue & White	1-10 bar

Technical Specifications

Y Pattern Valves Dimensions & Weights

For [BERMAD](#) angle, dual & T pattern, Please see our full engineering page.

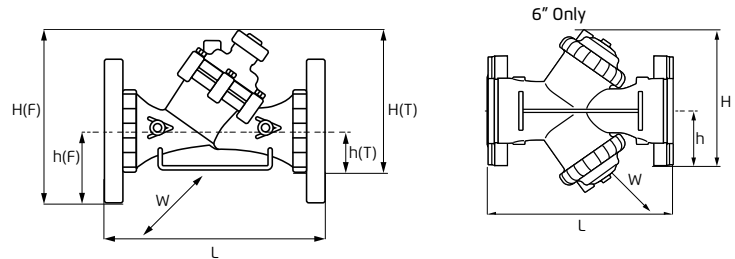

Sizes Inch ; DN	1½" ; 40	2" ; 50		2"L ; 50	2½" ; 65	Rc (BSP.T), NPT	3" ; 80	
End Connections	Rc (BSP.T), NPT	Rc (BSP.T), NPT	G (BSP.F)	Rc (BSP.T), NPT	G (BSP.F)	Rc (BSP.T), NPT	Universal Flanges	
							Metal	Plastic
L (mm)	200	230	230	230	230	298	308	308
H (F) (mm)	—	—	—	—	—	—	244	244
H (T) (mm)	173	173	173	187	187	199	—	—
h (F) (mm)	—	—	—	—	—	—	100	100
h (T) (mm)	40	40	40	43	43	55	—	—
W (mm)	97	97	97	135	135	135	200	200
CCDV (lit)	0.12	0.12	0.12	0.15	0.15	0.15	0.15	0.15
Weight (kg)	1.1	1.2	1.2	1.47	1.47	1.6	4.4	2.5

Sizes Inch ; DN	3"L ; 80L		4" ; 100		4"L ; 100L		6"R ; 150R	6" ; 150	6" ; 150		
End Connections	Rc (BSP.T), NPT	Universal Flanges		Universal Flanges		Universal Flanges		Groove	Universal Flanges		
		Metal	Plastic	Metal	Plastic	Metal	Plastic		Metal		
L (mm)	298	308	308	350	350	442	442	400	470	480	504
H (F) (mm)	—	317	317	329	329	340	340	286	377	198	286
H (T) (mm)	278	—	—	—	—	—	—	—	—	—	—
h (F) (mm)	—	100	100	112	112	112	112	57	149	100	143
h (T) (mm)	60	—	—	—	—	—	—	—	—	—	—
W (mm)	168	200	200	224	224	226	226	226	287	475	475
CCDV (lit)	0.62	0.62	0.62	0.62	0.62	1.15	1.15	1.15	1.15	2 x 0.62	2 x 0.62
Weight (kg)	3	4.6	3.7	7.4	4.6	13.5	10	8	16.5	11	12.5

CCDV = Control Chamber Displacement Volume • **BSP.T** = Internal Threaded • **BSP.F** = External Threaded • Other End Connections are available on request. For dimensions and weights of adapters or valve with adapters please consult with customer service

Flow Properties

Sizes Inch DN	1½" 40	2" 50	2"L 50L	2½" 65
KV	50	50	100	100

Sizes Inch DN	3" 80	3"L 80L	4" 100	4"L 100L	6" R 150L	6" 150
KV	100	200	200	340	340	400

Valve Flow Coefficient

$$\Delta P = \left(\frac{Q}{Kv} \right)^2$$

$Kv = m^3/h @ \Delta P \text{ of } 1 \text{ bar}$
 $Q = m^3/h$
 $\Delta P = \text{bar}$

Flow Chart

