

## Solenoid Controlled Valve

**Model: 1010** (Sizes 1.5" - 6"; DN40-150)

### Description

The BERMAD 1010 Solenoid Controlled Valve is a hydraulically operated diaphragm actuated control valve that either opens fully or shuts off in response to electric signals.

### Installation

1. Ensure enough space around the valve assembly for future maintenance and adjustments
2. Prior to valve installation, flush the pipeline to ensure a flow of clean fluid through the valve.
3. For future maintenance, install Isolation Valves upstream and downstream of the control valve
4. Install the valve in the pipeline with the valve flow direction arrows (visible around the side ports) in the actual flow direction.
5. For best performance, it is recommended to install the valve horizontally and upright.
6. After installation carefully inspect/correct any damaged accessories, piping, tubing, or fittings.
7. System power connections, control cabinet, controller, sensors & wiring must be carried out by authorized electrical engineer /electrician and comply with Electrical and Instrumentation Codes.
8. Cross-Check solenoid specifications with design requirements and solenoid/coil label.
9. Pull and connect a 3-wired cable (per each solenoid), from the control panel to the valve, for the solenoid actuation. Ensure approved cable protection. Confirm that the wires data meet solenoid specifications.  
Note: Energizing the solenoid coil when it is not fixed in its place, is dangerous and might burn the coil.
10. It is highly recommended to install a Bermad strainer (model 70F) upstream of the control valve, to prevent debris from damaging the valve's operation

### Commissioning & Calibration

1. Confirm that the supply pressure is typical.
2. Confirm that the In-line filter arrow [4A] direction is in the valve flow direction.
3. Open upstream and downstream isolating valves.
4. Allow the valve to open by using the solenoid manual override or by:  
Energizing the solenoid for a Normally Closed Valve, De-Energizing it for a Normally Open Valve & Latching it for a Last Position Valve.
5. Vent air from the valve control loop: During opening, use solenoid manual override to manually switch position, forcing the valve to close and then to open. At each position, vent air from the valve control loop by loosening tube fitting at the highest point, allowing the air to bleed. Retighten the fitting.
6. Confirm manual override has been disabled.
7. The Model 1010 has three modes of operation:
  - 7.1. Normally Closed Valve, with a Normally Open Solenoid. Energizing the solenoid will cause the valve to open.
  - 7.2. Normally Open Valve, with a Normally Closed Solenoid. Energizing the solenoid will cause the valve to Close.
  - 7.3. Last Position Valve, with a Latch Solenoid. Each electric command will cause the valve to alternate between fully open and closed.

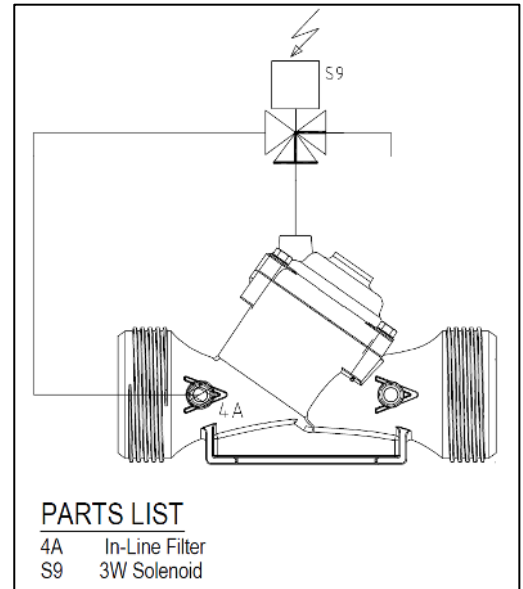

## Trouble-Shooting

1. **Valve fails to Open:** Check for sufficient inlet pressure, confirm solenoid is not jammed, confirm power supply to solenoid & confirm solenoid coil is not burned (N.C. valves).
2. **Valve fails to Close:** Confirm power supply to solenoid & confirm solenoid coil is not burned (N.O. valves), confirm solenoid is not jammed. Close both isolation valves, clean control filter [4A] & detect for clogged ports or fittings, check for debris trapped in the main valve, and confirm that the diaphragm is not leaking.

## Preventative Maintenance

1. System operating conditions and water quality will affect the valve and should be checked periodically to determine the required interval for preventative maintenance. The schedule below assumes good conditions and should be considered a minimum requirement.
2. Maintenance instructions:
  - 2.1. Tools required:
    - 2.1.1. Metric and imperial wrenches
    - 2.1.2. Anti seize grease
  - 2.2. Weekly:
    - 2.2.1. Visual inspection to locate leaks and external damages
  - 2.3. Yearly:
    - 2.3.1. Close isolating valves and clean line strainer and control loop In-line filter [4A].
    - 2.3.2. Perform a functional test including a closing test to verify valve sealing by De-Energizing the solenoid for a Normally Closed Valve, Energizing it for a Normally Open Valve & Latching it for a Last Position Valve.
  - 2.4. 3 – 5 Yearly:
    - 2.4.1. Inspect the internal condition of the valve:
      - 2.4.1.1. Close upstream and downstream isolating valves (and external operating pressure when used).
      - 2.4.1.2. Once the valve is fully isolated vent pressure by loosening a plug or a fitting.
      - 2.4.1.3. Unscrew cover fastening bolts and remove cover. Disassemble control tubs.
    - 2.4.2. Inspect the diaphragm and the sealing area on the valve body.
    - 2.4.3. Replace worn parts and all the Elastomers. Lubricate the bolts and screws threads with Anti seize grease.
  - 2.5. It is highly recommended to stock a reserve solenoid and an actuator assembly for each size. This allows minimum system field work and system down time
  - 2.6. Winterizing/freezing prevention: drain the valve & the valve accessories (pilot, solenoid) on time

## Spare parts

Bermad has a convenient and easy to use ordering guide for valve spare-parts and control system components at

<https://www.bermad.com/waterworks-downloads/>

For solenoid valves refer to model and S/N on solenoid tags.