

Pressure Reducing Valve

Model: 1020 (Sizes 1.5" - 6"; DN40-150)

Description

The BERMAD 1020 Pressure Reducing Valve is a hydraulically operated diaphragm actuated control valve that reduces higher upstream pressure to lower constant downstream pressure, regardless of varying demand or upstream pressure.

Installation

1. Ensure enough space around the valve assembly for future maintenance and adjustments
2. Prior to valve installation, flush the pipeline to ensure a flow of clean fluid through the valve.
3. Install Isolation Valves upstream and downstream of the control valve
4. Install the valve in the pipeline with the valve flow direction arrows (visible around the side port) in the actual flow direction.
5. For best performance, it is recommended to install the valve horizontally and upright.
6. After installation carefully inspect/correct any damaged accessories, piping, tubing, or fittings.
7. Install a pressure gauge downstream of the valve or on the pilot.
8. It is highly recommended to install a Bermad strainer (model 70F) upstream of the control valve, to prevent debris from damaging the valve's operation
9. Install a pressure relief valve Bermad model 103Q for protection against momentary pressure peaks.

Commissioning & Calibration

1. Confirm that the supply pressure is typical.
2. Confirm that the In-line filter arrow [4A] direction is in the valve flow direction.
3. The Pressure Reducing pilot [2PBL] has been calibrated at the factory and the set pressure is indicated on the pilot cover. If the pilot set pressure is not compatible with your requirements, then the pilot needs to be reset.
 - 3.1. If the pilot needs to be reset then loosen the pilot's adjustment screw locking nut and release the adjustment screw turning it counter-clockwise until it is completely loose.
4. Slowly fully open the upstream isolating valve and partially the downstream isolating valve, to fill-up, in a slow and controlled manner the consumers line downstream from the pressure reducing valve. Confirm that the supply pressure and the flow through the system are typical. If necessary create flow by opening a hydrant, or reduce the flow by adjusting the downstream isolating valve
 - 4.1. If the pilot adjustment screw has been loosened in preparation for resetting, the main valve will close shortly after opening the upstream isolation valve.
5. Vent air from the valve's control loop by loosening cover tube fitting at the highest point, allowing all air to bleed. Retighten the tube fitting.
6. Allow the pressure that appears in the downstream pressure gauge to stabilize, meeting the marked set pressure.
7. If the pilot has been reset according to line 3.1 or set pressure is either different from the design or the requirements have been changed. The valve will need to be readjusted:
 - 7.1. Unlock the pilots locking nut and slowly turn the pilot adjusting screw Clock-Wise to increase set pressure and Counter - Clock-Wise to decrease it. Allow the 1020 to react and the pressure to stabilize.
 - 7.2. After the pressure is stabilized and the correct pressure is confirmed, retighten the adjustment screw locking nut.
8. Open fully the downstream isolating valve. The 1020 pressure reducing valve is now operational and in service.
9. The Restriction [31] enables the 2-Way control & reduces valve closing speed.
10. Calibrating Pressure Reducing Systems that include parallel By-Pass Pressure Reducing Valves, require calibrating each of the PRV's separately, while the parallel PRV/s is/are closed. Calibration should refer to a shared pressure gauge, installed downstream from the system. For best & long term performance, set larger PRV to 0.5 bar/ 7 psi lower than smaller PRV.
11. Relief Valves if fitted should be set 1 bar / 15 psi above system highest set-pressure.

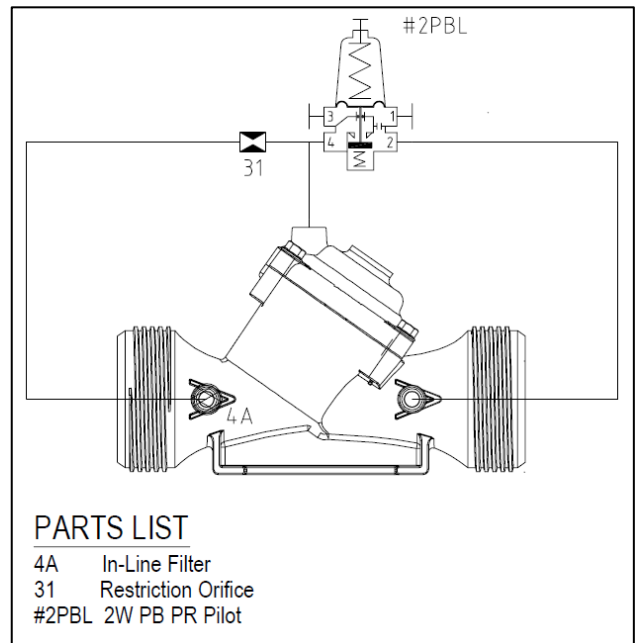

Trouble-Shooting

10. **Valve fails to Open:** Check for sufficient inlet pressure, create demand/flow.
11. **Valve fails to Close:** Close both isolation valves, clean control filter [4A] & detect for clogged ports or fittings, check for debris trapped in the main valve, and confirm that the diaphragm is not leaking.
12. **Valve fails or Regulates Erratically:** Release air trapped in the valves control chamber, clean control filter [4A], check for debris caught in the valve passage.

Preventative Maintenance

1. System operating conditions and water quality will affect the valve and should be checked periodically to determine the required interval for preventative maintenance. The schedule below assumes good conditions and should be considered a minimum requirement.
2. Maintenance instructions:
 - 2.1.1. Tools required:
 - 2.1.1.1. Metric and imperial wrenches
 - 2.1.1.2. Anti seize grease
 - 2.2. Weekly:
 - 2.2.1. Visual inspection to locate leaks and external damages
 - 2.2.2. Check pressure gauge read correct pressures
 - 2.3. Yearly:
 - 2.3.1. Close isolating valves and clean line strainer and control loop filter.
 - 2.3.2. Perform a functional test including a closing test to verify valve sealing.
 - 2.4. 3 – 5 Yearly:
 - 2.4.1. Inspect the internal condition of the valve:
 - 2.4.1.1. Close upstream and downstream isolating valves (and external operating pressure when used).
 - 2.4.1.2. Once the valve is fully isolated vent pressure by loosening a plug or a fitting.
 - 2.4.1.3. Unscrew cover fastening bolts and remove cover. Disassemble necessary control tubs.
 - 2.4.2. Inspect the diaphragm and the sealing area on the valve body.
 - 2.4.3. Replace worn parts and all the Elastomers. Lubricate the bolts and screws threads with Anti seize grease.
 - 2.5. It is highly recommended to stock a reserve parts assembly for each size. This allows minimum system field work. And system down time.
 - 2.6. Winterizing/freezing prevention: drain the valve & the valve accessories (pilot, solenoid) on time

Spare parts

Bermad has a convenient and easy to use ordering guide for valve spare-parts and control system components at

<https://www.bermad.com/waterworks-downloads/>

For solenoid valves refer to model and S/N on solenoid tags.

Pub # : IOM_WW-1020	By: NS 10/20	Rev:01	File name: IOM_WW-1020
---------------------	--------------	--------	------------------------



www.bermad.com

The information contained herein may be changed by Bermad without notice. Bermad shall not be held liable for any errors.
©Copyright 2010-2020 Bermad CS Ltd. Nov 2020