

Level Control Valve with Modulating Horizontal Float

Model: 1050-60 (Sizes 1.5"- 6"; DN40-150)

Description

The Model 1050-60 Level Control Valve with Modulating Horizontal Float is a hydraulically operated, diaphragm actuated, control valve that hydraulically controls reservoir filling to maintain constant water level, regardless of fluctuating demand.

Installation

1. Ensure enough space around the valve assembly for future maintenance and adjustments
2. Prior to valve installation, flush the pipeline to ensure a flow of clean fluid through the valve.
3. For future maintenance, install Isolation Valves upstream and downstream of the BERMAD control valve
4. Install the valve in the pipeline with the valve flow direction arrows (visible around the side ports) in the actual flow direction.
5. For best performance, it is recommended to install the valve horizontally and upright.
6. It is highly recommended to install a Bermad strainer (model 70F) upstream of the control valve, to prevent debris from damaging the valve's operation.
7. Install the float pilot assembly near the reservoir man-hole, at a still place or at an internal stilling tank.
8. Determine the desired float location at the reservoir desired level and up-to 20 cm / 8 inch above it.
9. Fix the float to the reservoir wall, or other stable element, ensuring the float will remain still in its original orientation.
10. Anchor the float arm position by tightening the arm base screws, using 7/16" spanners.
11. Thread-in the float ball on to the arm and lock it near the edge of the arm, using a 7/16" spanner. Tighten the lock nut.
12. Pull a control tube, from the valve to the float. ½" up to 15 m long, ¾" up to 30 m long.
Note: When the float is installed more than 5 meters above the valve – consult Bermad.
13. Connect the control tube ends, using ⅜" copper or reinforced plastic tube, to the valve and to the float, according to control drawing below, from cock valve [1] to float inlet port.
14. After installation carefully inspect/correct any damaged accessories, piping, tubing, or fittings.

Commissioning & Calibration

1. Confirm that the supply pressure is typical.
2. Confirm that the In-line filter arrow [4A] direction is in the valve flow direction.
3. Confirm that ball valve [1] is open (handle parallel to ball-valve body).
4. Adjust the water level by setting the float arm angle: Hold the float arm at its upper position & set the angle to 100 mm / 4 inch below desired upper level (but not higher than 150 mm / 6 inch below over-flow level).
5. Open upstream and downstream isolating valves. Allow the 1050-60 to open (ensuring the float ball is at its lower position) and fill-up the reservoir.
6. Vent air from the valve control loop: During filling the reservoir move the float arm manually to its upper position, forcing the valve to close, then to its lower position, forcing the valve to open. At each position, vent air from the valve control loop by loosening tube fitting at the highest point on the valve & at pilot float inlet port, allowing the air to bleed. Retighten the fittings eyebolts.
7. Calibrating reservoir level: Ensure that the 1050-60 closes as the water level reaches the set-level. If the 1050-60 has not closed, change the float arm angle down, to lower level setting or up to raise it, until the valve closes automatically at the desired upper-level. Allow the water level to drop by consuming from the reservoir or by draining it. This will cause the valve to open.
8. The needle valve [5] enables the 2-Way control and controls valve closing speed. It should be set between 1 to 2 turns open, according to valve size, float distance & elevation and the desired closing speed.
9. Ball valve [1] enables manual closing.

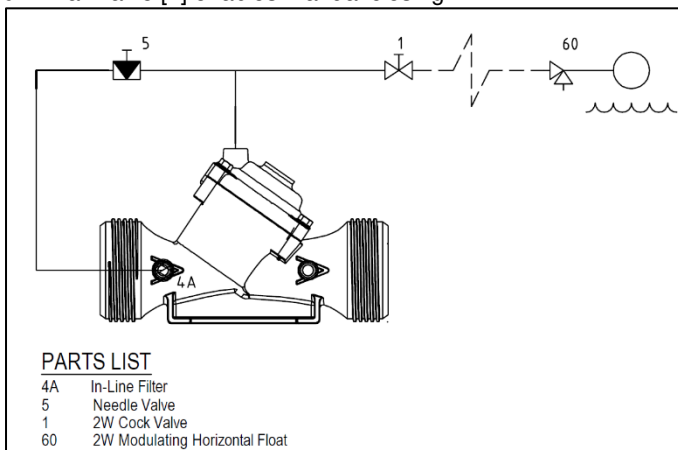

www.bermad.com

The information contained herein may be changed by Bermad without notice. Bermad shall not be held liable for any errors.
©Copyright 2010-2020 Bermad CS Ltd. Nov 2020

Trouble-Shooting

1. **Valve fails to Open:** Check for sufficient inlet pressure, create demand/flow, confirm float setting & check ball valve status, check needle valve opening rate, confirm control tube length, size & elevation, detect for clogged ports or fittings between valve & float.
2. **Valve fails to Close:** Confirm float setting, check ball valve status, needle valve opening rate, close both isolation valves, clean control filter [4A] & detect for clogged ports or fittings, check if any debris trapped in the main valve, confirm diaphragm is not leaking.
3. **Valve fails or Regulates:** Check ball valve status, release air trapped in the 1050-60 control chamber.

Preventative Maintenance

1. System operating conditions and water quality will affect the valve and should be checked periodically to determine the required interval for preventative maintenance. The schedule below assumes good conditions and should be considered a minimum requirement.
2. Maintenance instructions:
 - 2.1. Tools required:
 - 2.1.1. Metric and imperial wrenches
 - 2.1.2. Anti seize grease
 - 2.2. Weekly:
 - 2.2.1. Visual inspection to locate leaks and external damages
 - 2.2.2. Confirm float setting and water level
 - 2.3. Yearly:
 - 2.3.1. Close isolating valves and clean line strainer and control loop In-line filter [4A].
 - 2.3.2. Perform a functional test including a closing test to verify valve sealing.
 - 2.4. 3 – 5 Yearly:
 - 2.4.1. Inspect the internal condition of the valve:
 - 2.4.1.1. Close upstream and downstream isolating valves (and external operating pressure when used).
 - 2.4.1.2. Once the valve is fully isolated vent pressure by loosening a plug or a fitting.
 - 2.4.1.3. Unscrew cover fastening bolts and remove cover. Disassemble control tubs.
 - 2.4.2. Inspect the diaphragm and the sealing area on the valve body.
 - 2.4.3. Replace worn parts and all the Elastomers. Lubricate the bolts and screws threads with Anti seize grease.
 - 2.5. It is highly recommended to stock a reserve parts assembly for each size. This allows minimum system field work. And system down time.
 - 2.6. Winterizing/freezing prevention: drain the valve & the valve accessories (pilot, solenoid) on time

Spare parts

Bermad has a convenient and easy to use ordering guide for valve spare-parts and control system components at

<https://www.bermad.com/waterworks-downloads/>

For solenoid valves refer to model and S/N on solenoid tags.

Pub # : IOM_WW-1050-60	By: NS 05/20	Rev:01	File name: IOM_WW-1050-60
------------------------	--------------	--------	---------------------------



www.bermad.com

The information contained herein may be changed by Bermad without notice. Bermad shall not be held liable for any errors.
©Copyright 2010-2020 Bermad CS Ltd. Nov 2020