

LEVEL CONTROL VALVE

with Modulating Horizontal Float

Model 1050-60

Hydraulically operated, float controlled valve that controls reservoir filling and reservoir level. Reservoir filling is accomplished in response to hydraulically controlled modulating horizontal float that maintains a constant water level, regardless of fluctuating demand.

The BERMAD 1000 is at the leading edge of control valve design, providing a valve that is free of the typical limitations associated with standard control valves. A unitized flexible diaphragm & guided plug provide a significantly 'look through' passage resulting in accurate & stable regulation and high flow capacity.

The 1000 unique composite structure allows fast & simple maintenance by easy replacing of lightweight diaphragm assembly. It has a wide range of end connection types and sizes, including articulated flange connections isolating the valve from pipeline bending & pressure stresses.



Features and Benefits

- Easy set-up
 - Super light weight
 - Line pressure driven - no external power needed
 - Easy pressure setting - in site or pre-ordered
 - Adaptable on-site to a wide range of end connection
- Simple and durable design
 - Excellent cavitation resistance
 - Highly durable construction & material - No rust
 - Unitized actuator unit - open, replace, close
 - In-line serviceable - no need to remove from line
- All the benefits of a diaphragm actuated control valve
 - Wide flow range
 - Low flow stability
 - Drip tight sealing
 - Obstacle free flow pass
 - Easy addition of hydraulic features

Typical Applications

- Level Control for small to medium potable water tanks, pressure break tanks, treatment buffer etc'.
- Constant level control system where maintaining full water reserve is required

Typical Installation

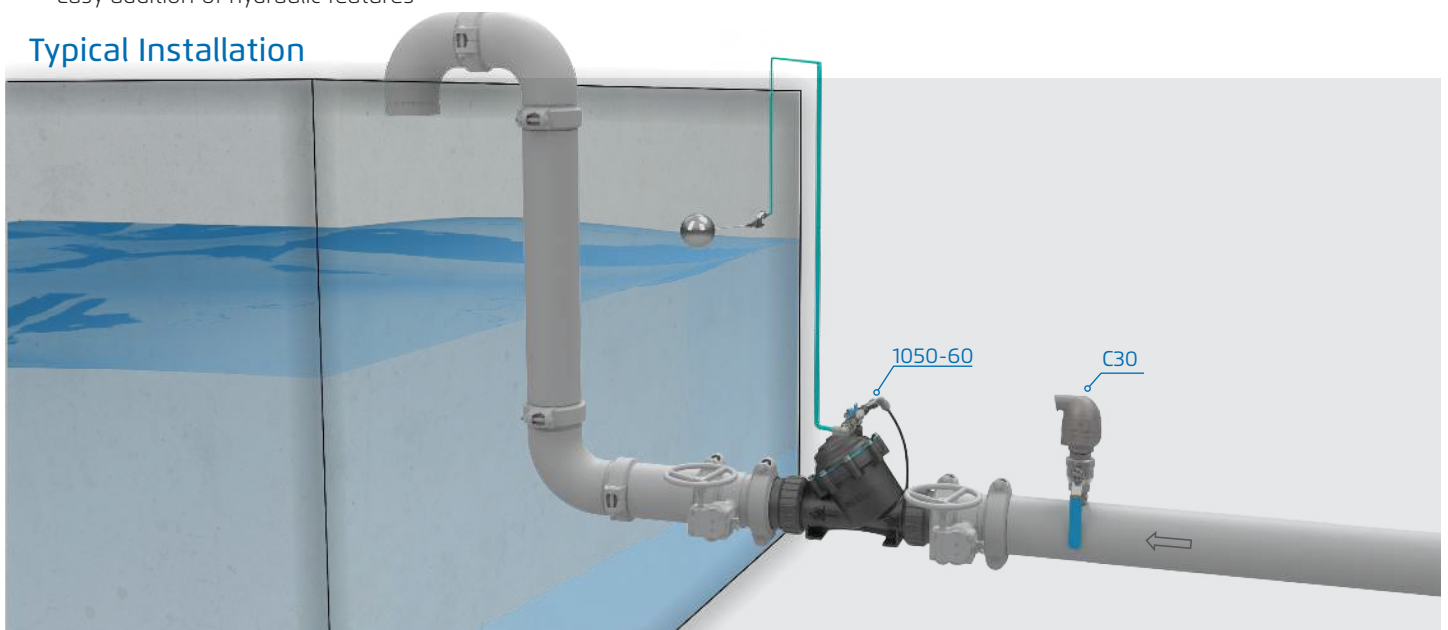

Advanced Composite Polymer Material

Strong, inert and light weight; bringing the next generation of materials to the water supply industry

Unitized Actuator Assembly

Allows fast and simple in-line maintenance

Reinforced Rolling Diaphragm

Durable and flexible operation

Unobstructed Flow

High capacity semi-straight flow for exceptionally low head loss

Internal Threads or Adaptors

Flexible option for Threaded, Groove or Flange connection

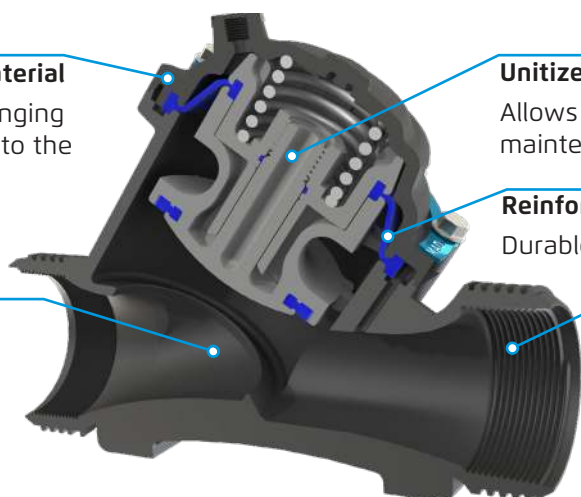

Technical Specifications

End Connections:
Threaded - Female NPT or BSPT:

- 1½"EN, 2"ES/EN, 3"ES/EN

Grooved - According to ANSI C606-81:

- Adaptors on Threaded Body: 2"ES/EN, 3"ES/EN, 4"ES

Flanged - ISO-7005-2 (PN10/PN16), ANSI #125/ANSI #150, JIS K-10:

- Universal Adaptors on Threaded Body: 3"ES/EN, 4"ES

Pressure Rating:

- 1½"EN-4"ES: 250 psi; PN16

Valve Pattern:

- Y (Oblique)
- Angle - consult factory for available sizes

Temperature: For Cold Water Applications

Consult BERMAD For hot water applications.

Main Valve Materials:
Body, Cover and Actuator assembly:

Reinforced Polyamide

Cover Bolts: Stainless Steel 304

Spring: Stainless Steel 302 (Optional 316)

Diaphragm: EPDM

Seals: EPDM

Trim:

Accessories: Stainless Steel / Bronze & Brass / Polyamide

Tubing: Polypropylene

Fittings: Stainless Steel / Brass / Acetal

Notes

- Recommended continuous flow velocity: 0.3-20 ft/sec; 0.1-6.0 m/sec
- Minimum operating pressure: 10 psi / 0.7 bar. For lower pressure requirements consult factory

How To Order

Please Specify the requested valve in the following sequence:

WW	2"	1050-60	EN	P2	Y	Q	VN	UC	460	PA	HR	
Segment	Model	End Connection	Body Threads	Code	Voltage	Code	Additional Attributes (Multiple Options Permitted)		Code			
WW BC	1050-60	Threaded	BSPT Female	BP	24VAC/50Hz	4A	St.St. 316 All Control Accessories		N			
Size	Code	Type	Code		24VAC/60Hz	46	3-Way Control		X			
Design	EN	ES	High Flow	EN	24VDC	4D	Trim Isolation Ball Valves		h			
1½", DN40	1½"	-	Normal Flow	ES	220VAC/50-60Hz	2A	Pressure Gauge		6			
2", DN50	2"	2"			220VDC	2D	Horizontal Installation, Left Side Circuit (Standard)		HL			
3", DN80	3"	3"			110VAC/50-60Hz	5A	Horizontal Installation, Right Side Circuit		HR			
4", DN100	4"	4"			110VDC	5D						
					12VDC	1D						
Standard Configurations:	Main Valve Compliance	Code	Orientation	Code	Construction Material	Code	Coating	Code	Main Valve Position (When Solenoid De-energized)	Code	Tubings & Fittings	Code
	Potable Water	P2	Y Oblique	Y	Nylon Glass Reinforced	Q	Uncoated	UC	Normally Closed	C	Polypropylene Tubing and Acetal Fittings	PA
									Normally Open	O		
									Last Position	P		
									Latch Solenoid	S		



For detailed Engineering & Specification data, IOM and CAD Drawings, visit the Model Page on the [BERMAD](http://www.bermad.com) website.

www.bermad.com

The information contained herein may be changed by BERMAD without notice. BERMAD shall not be held liable for any errors.
© Copyright 2010-2020 BERMAD CS Ltd.