

## **Burst Control Valve Excessive Flow**

(Sizes 1½-14"; DN40-350)

### **Description**

The Model 790-M Burst Control Valve is a hydraulically operated, diaphragm actuated control valve that upon sensing flow in excess of the burst flow setting shuts off and locks drip tight, until it is manually reset. As long as flow is lower than the burst flow setting, the valve remains fully open, minimizing head loss.

### **Installation**

1. Ensure enough space around the valve assembly for future maintenance and adjustments.
2. Prior to valve installation, flush the pipeline to insure flow of clean fluid through the valve.
3. For future maintenance, install Isolation gate valves upstream and downstream from Bermad control valve.
4. Install the valve in the pipeline with the valve flow direction arrow in the actual flow direction. Use the lifting rings provided on the main valve cover for installing the valve.
5. For best performance, it is recommended to install the valve horizontally and upright. For different valve positions – consult Bermad.
6. After installation carefully inspect/correct any damaged accessories, piping, tubing, or fittings.
7. It is highly recommended to install a strainer Bermad model 70F upstream from the 790-M, to prevent debris from damaging valve operation.
8. It is recommended to install a water meter on the pipe line to enable accurate adjustment.

### **Commissioning, Resetting & Calibration**

1. Confirm that cock valves [1], [3] are open (handle parallel to cock valve body) and that 3-way cock valve [6] has its handle in the horizontal position.
2. Open fully the upstream isolating valve and slowly fully open the downstream isolating valve, to fill-up, in a controlled manner, the consumers line downstream from the 790-M.
3. Vent air from the valve's control loop by loosening cover tube fitting & pilot sensing chambers at the highest point, allowing all air to bleed. Retighten the tube fitting eyebolt.
4. The Model 790-M is factory set according to the design burst flow request. The set burst flow is marked on the pilot's label.
5. Confirm that the supply pressure and the flow through the system, inspected in the system Water-meter, are typical. If necessary, increase flow by opening a hydrant to reach the system's maximum operating flow.
6. Close cock valve [3]. Valve is now ready to close during burst excessive flow.
7. If the set burst flow is either different from the design or the requirements have been changed, then refer to "Calibration" - (step 9 of Commissioning, Resetting & Calibration).
8. Resetting after valve shut off
  - 8.1. Check the reasons and/or fix the pipeline.
  - 8.2. Open cock valve [3] to vent the trapped pressure from the upper control-chamber.
  - 8.3. Repeat steps 5 & 6 of Commissioning, Resetting & Calibration.
9. Calibration
  - 9.1. Position 3-way cock valve [6] lever in vertical position. The valve will close.
  - 9.2. Turn the flow stem [M] CCW until fully released.
  - 9.3. Turn pilot #83-DR calibration screw CW until fully tight.
  - 9.4. Confirm that cock valves [1], [3] are open (handle parallel to cock valve body) and that 3-way cock valve [6] has its handle in the horizontal position. The valve will open.
  - 9.5. Increase system consumption to burst excessive flow.
  - 9.6. Read the differential pressure across the valve. (It is recommended to use a differential pressure gauge, if not available use the same gauge for upstream and downstream pressure reading).
  - 9.7. Turn the flow stem CW until the differential pressure across the valve reaches 0.4 bar / 6 psi. Tighten the flow stem locking nut. The flow stem should turn smoothly. Should it not, do not force it, instead contact a factory representative.
  - 9.8. Slowly turn the pilot calibration screw CCW until water start dripping through cock valve [3]. Retighten the screw CW until the drip stop & ¼ of a turn more. Tighten the pilot calibration screw locking nut.
  - 9.9. Close cock valve [3]. Valve is now ready to close during burst excessive flow.
10. Manually Closing and Opening

It is possible to close the valve manually in order to check its operation or for usage as an isolating valve.

  - 10.1. To manually close the valve, position the 3-way cock valve [6] lever in vertical position.
  - 10.2. To reopen the valve, position the 3-way cock valve [6] lever in horizontal position and follow "Resetting after valve shut off" procedure (step 8 of Commissioning, Resetting & Calibration).

## Control Drawing

### PARTS LIST

1	2W Cock Valve
3	2W Cock Valve
4	Control Filter
6	3W Cock Valve
#83-DR	2W High Sensitive Pressure Sustaining Pilot
M	Mechanical Closure

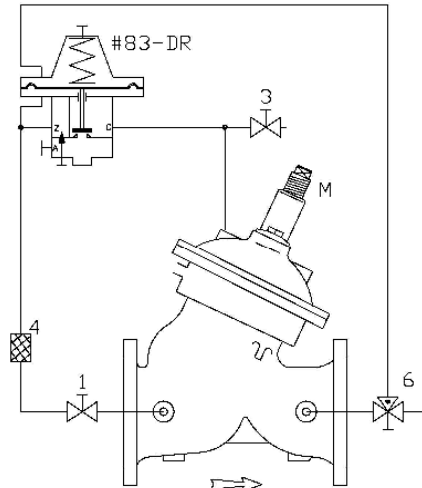

## Trouble-Shooting

- Valve fails to Open:** Check for sufficient inlet pressure, create demand/flow, confirm pilot setting & check cock valves status.
- Valve fails to Close:** Create demand/flow, confirm pilot setting, check cock valves status, clean control filter & detect for clogged ports or fittings, check if any debris trapped in the main valve, confirm diaphragm is not leaking.

## Preventative Maintenance

- System operating conditions that effect on the valve should be checked periodically to determent the required preventative maintenance schedule.
- Maintenance instructions:
  - Tools required:
    - Metric and imperial wrenches
    - Anti seize grease
  - Visual inspection to locate leaks and external damages
  - Functional inspection including: closing, opening and regulation.
  - Close upstream and downstream isolating valves (and external operating pressure when used).
  - Once the valve is fully isolated vent pressure by loosening a plug or a fitting.
  - Open the stud nuts and remove the actuator as one unit from the valve body. Disassemble necessary control tubs.
  - It is highly recommended to stock a reserve actuator assembly for each size. This allows minimum system field work and system down time.
  - Disassemble the actuator and examine its parts carefully for signs of wear, corrosion, or any other abnormal conditions.
  - Replace worn parts and all the Elastomers. Lubricate the bolts and studs threads with Anti seize grease.

## Spare parts

Bermad has a convenient and easy to use ordering guide for valve spare-parts and control system components. For solenoid valves refer to model and S/N on solenoid tags.

Pub # : IOMEW790-M

By: MB 2/10

Rev: 02RL-10/15

File name:  
WW\_790-M\_IOM\_English\_10-15

[appliceng@bermad.com](mailto:appliceng@bermad.com) • [www.bermad.com](http://www.bermad.com)

The information contained in this document is subject to change without notice.

BERMAD shall not be liable for any errors contained herein. All Rights Reserved. © Copyright by BERMAD Control Valves.