

Pressure Reducing and Sustaining Valve

(Sizes 6"-16"; DN150-400)

Description

The Model 823 Pressure Reducing and Sustaining Valve is a hydraulically operated, diaphragm actuated control valve with two independent functions:

- During excessive upstream pressure, it prevents downstream pressure from rising above maximum pre-set.
- During upstream pressure drop, it sustains minimum pre-set upstream (back) pressure.

Installation

1. Ensure enough space around the valve assembly for future maintenance and adjustments.
2. Prior to valve installation, flush the pipeline to insure flow of clean fluid through the valve
3. For future maintenance, install Isolation gate valves upstream and downstream from Bermad control valve.
4. Install the valve in the pipeline with the valve flow direction arrow in the actual flow direction. Use the lifting ring provided on the main valve cover for installing the valve.
5. For best performance, it is recommended to install the valve horizontally and upright. For different valve positions – consult Bermad.
6. After installation carefully inspect/correct any damaged accessories, piping, tubing, or fittings.
7. Install pressure gauges (instead of the plastic plug on the pilots)
8. It is highly recommended to install a strainer Bermad model 80F upstream from the pressure reducing valve, to prevent debris from damaging valve operation.
9. Install a pressure relief valve Bermad model 83Q for protection against momentary pressure peaks.

Commissioning & Calibration

1. Confirm that cock valves [1] & [2] are open (handle parallel to cock-valve body).
2. Open fully the upstream isolating valve and partially the downstream isolating valve, to fill-up, in a slow and controlled manner, the consumers line downstream from the pressure reducing system.
3. Confirm that the supply pressure and the flow through the system are typical. If necessary, create flow by opening a hydrant, or reduce the flow/pressure by adjusting the downstream/upstream isolating valves.
4. Vent air from the valve's control loop by loosening cover tube fitting at the highest point, allowing all air to bleed. Retighten the tube fitting eyebolt.
5. The Model 823 is factory set according to the design pressure request. The set pressure is marked on each of the pilot's label:
 - 5.1. The set downstream pressure on the Pressure Reducing Pilot [PRP] (#2) label.
 - 5.2. The set upstream pressure on the Pressure Sustaining Pilot [PSP] (#3) label.
6. If the set pressures are either different from the design or the requirements have been changed, change settings according to the following:
 - 6.1. Unlock the PRP locking nut and slowly turn the pilot adjusting screw Clock-Wise to increase set pressure and Counter -Clock-Wise to decrease it. Allow the 823 to react and the downstream pressure to stabilize.
 - 6.2. After the pressure is stabilized, lock the PRP locking nut and open fully the downstream isolating valve.
 - 6.3. Close the upstream isolating valve to reduce 823 inlet pressure. Ensure that the 823 sustains the upstream pressure, preventing it from decreasing below setting, even when the upstream isolating valve is almost closed.
 - 6.4. Unlock the PSP locking nut and slowly turn the pilot adjusting screw Clock-Wise to increase set pressure and Counter -Clock-Wise to decrease it. Allow the 823 to react and the upstream pressure to stabilize.
 - 6.5. After the pressure is stabilized, lock the PSP locking nut and open fully the upstream isolating valve.
7. The internal needle valve [21] in pilot (#3) enables the 2-Way control & reduces valve closing speed.
8. Calibrating Pressure Reducing Systems that include parallel By-Pass PR Valves, require calibrating each of the PR Valves separately, while the parallel PR Valve/s is closed. Calibration should refer to a shared pressure gauge, installed downstream from the system. For best & long term performance, set larger PRV to 0.5 bar lower than smaller PRV.
9. Relief Valves should be set 1 bar above system highest set-pressure.

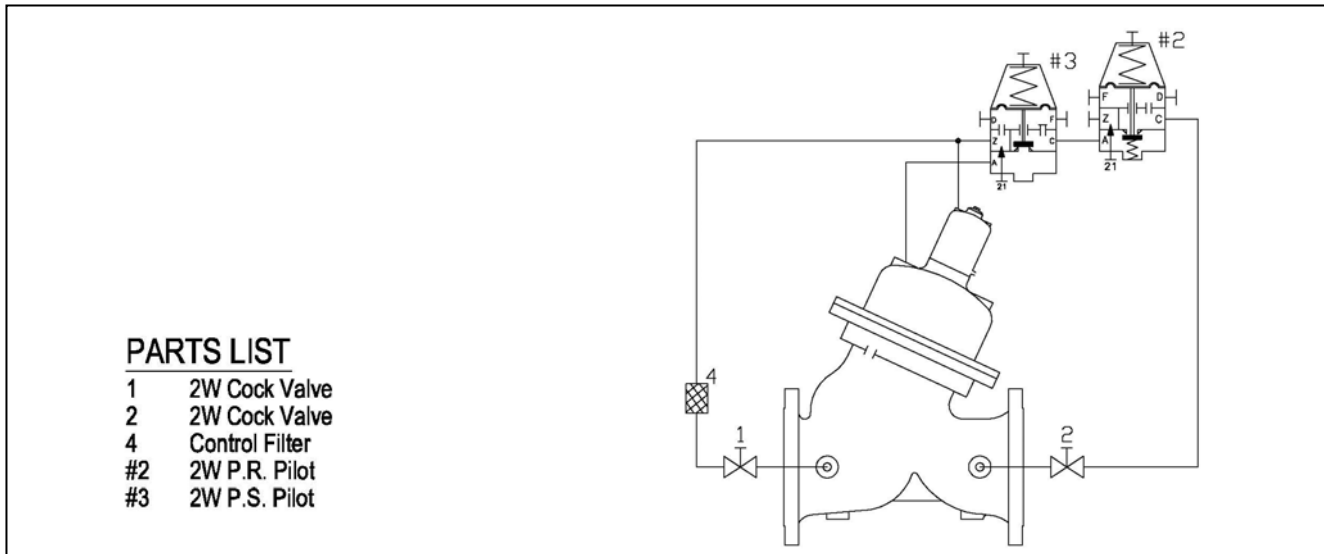

Trouble-Shooting

- Valve fails to Open:** Check for sufficient inlet pressure, create demand/flow, confirm pilots setting & check cock valves status.
- Valve fails to Close:** Create demand/flow, confirm pilot setting, check needle & cock valves status, clean control filter & detect for clogged ports or fittings, check if any debris trapped in the main valve, confirm diaphragm is not leaking.
- Valve fails to Regulate:** Check needle valves setting, release air trapped in the control chamber & check cock valves status.

Preventative Maintenance

- System operating conditions that effect on the valve should be checked periodically to determine the required preventative maintenance schedule.
- Maintenance instructions:
 - Tools required:
 - Metric and imperial wrenches
 - Anti seize grease
 - Visual inspection to locate leaks and external damages
 - Functional inspection including: closing, opening and regulation.
 - Close upstream and downstream isolating valves (and external operating pressure when used).
 - Once the valve is fully isolated vent pressure by loosening a plug or a fitting.
 - Open the stud nuts and remove the actuator as one unit from the valve body. Disassemble necessary control tubs.
 - It is highly recommended to stock a reserve actuator assembly for each size. This allows minimum system field work and system down time.
 - Disassemble the actuator and examine its parts carefully for signs of wear, corrosion, or any other abnormal conditions.
 - Replace worn parts and all the Elastomers. Lubricate the bolts and studs threads with Anti seize grease.

Spare parts

Bermad has a convenient and easy to use ordering guide for valve spare-parts and control system components. For solenoid valves refer to model and S/N on solenoid tags.

Pub # : IOMEW823-PA

By: RL 4/08

Rev: 01RL-4/08

File name: IOMEW823-PA_04_08

appliceng@bermad.com • www.bermad.com

The information contained in this document is subject to change without notice.

BERMAD shall not be liable for any errors contained herein. All Rights Reserved. © Copyright by BERMAD Control Valves.

