

Hydraulically Controlled, Anti-Columning Deluge Valve with EasyLock™ Manual Reset

Model: FP 400E-5M

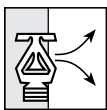

Typical Applications



Automatic spray or foam systems

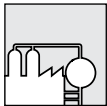

Petrochemical facilities

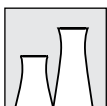

Power plants & transformers



Flammable materials storage



Hydraulic remote controlled systems

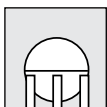

Gas storage tanks

Features and Benefits

- **Latch open** – Closes upon local reset only
- **One-piece molded elastomeric moving part** – No maintenance required
- **Simple design** – Cost effective
- **Obstacle-free full-bore** – Uncompromising reliability
- **Factory pre-assembled trim** – Out-of-box quality
- **In-line serviceable** – Minimal down time

Optional Features

- **Water motor alarm**
- **Alarm pressure-switch** (code: P or P7)
- **Seawater service** (add FS as prefix to model)
- **Valve Position Single/Double Limit Switches**

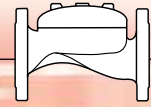

Operation

The BERMAD Model FP 400E-5M is suitable for systems that include wet pilot lines with closed fusible plugs (thermal releases), and piping systems with a wide variety of open nozzles. Providing boosted local pressure release from its control chamber, Model FP 400E-5M is recommended for systems with a remote and/or elevated fusible plugs line. In the SET position, line-pressure supplied to both the main valve's control chamber [1] and to an Adjustable Pressure Operated Relief Valve (PORV-A) [2] via the priming line [3], an EasyLock Manual Reset [4], the wet pilot line [5] restriction [6], and a check valve [7] is trapped by the EasyLock internal check valve, by the closed PORV, and a closed Manual Emergency Release [8]. The trapped pressure holds the main valve's diaphragm and plug against the valve seat [9], sealing it drip-tight and keeping the system piping dry. The AORV is held closed by the line pressure in the wet pilot line.

Under FIRE or TEST conditions, a pilot line hydraulic pressure drop opens the AORV. Pressure is then released from the main valve's control chamber through the opened AORV, or the Manual Emergency Release. The EasyLock prevents line pressure from entering the control chamber, allowing the main valve to latch open and water to flow into the system piping and to the alarm device.

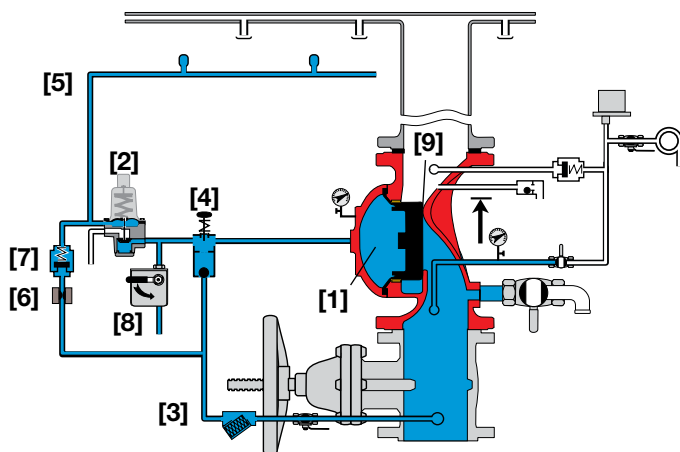

Valve Closed (set position)

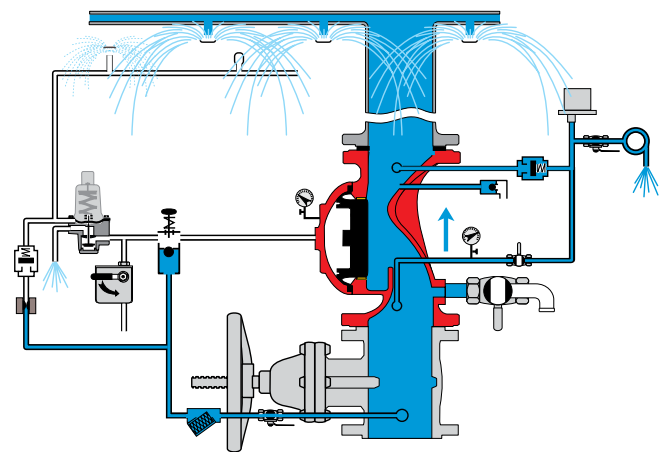

Valve Open (operating condition)

Engineer Specifications

- The deluge valve shall be a UL-Listed, hydraulically controlled elastomeric type globe valve with a **rolling-diaphragm**.
- The valve shall have an **unobstructed flow path** with no stem guide or **supporting ribs**.
- Valve actuation shall be accomplished by a fully peripherally supported, one-piece balanced rolling-diaphragm, vulcanized with a rugged radial seal disk. The diaphragm assembly shall be the only moving part.
- The valve shall have a removable cover for quick in-line service enabling all necessary inspection and servicing.
- The control trim materials shall consist of S.S.316 tubing and fittings, and plated brass accessories, including local **EasyLock** Manual Reset, PORV-A adjustable hydraulic pilot valve, Y strainer and Manual Emergency Release.
- The control trim shall be supplied as an assembly, pre-assembled and hydraulically tested at an ISO 9000 and 9001 certified factory.

The Hydraulically Controlled, Anti-Columning Deluge Valve shall latch open in response to activation of a releasing device. The valve shall reset to the closed position only upon local manual activation of the reset device.

BERMAD Fire Protection

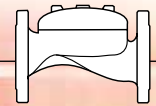



Model: FP 400E-5M

400 Series

System Components

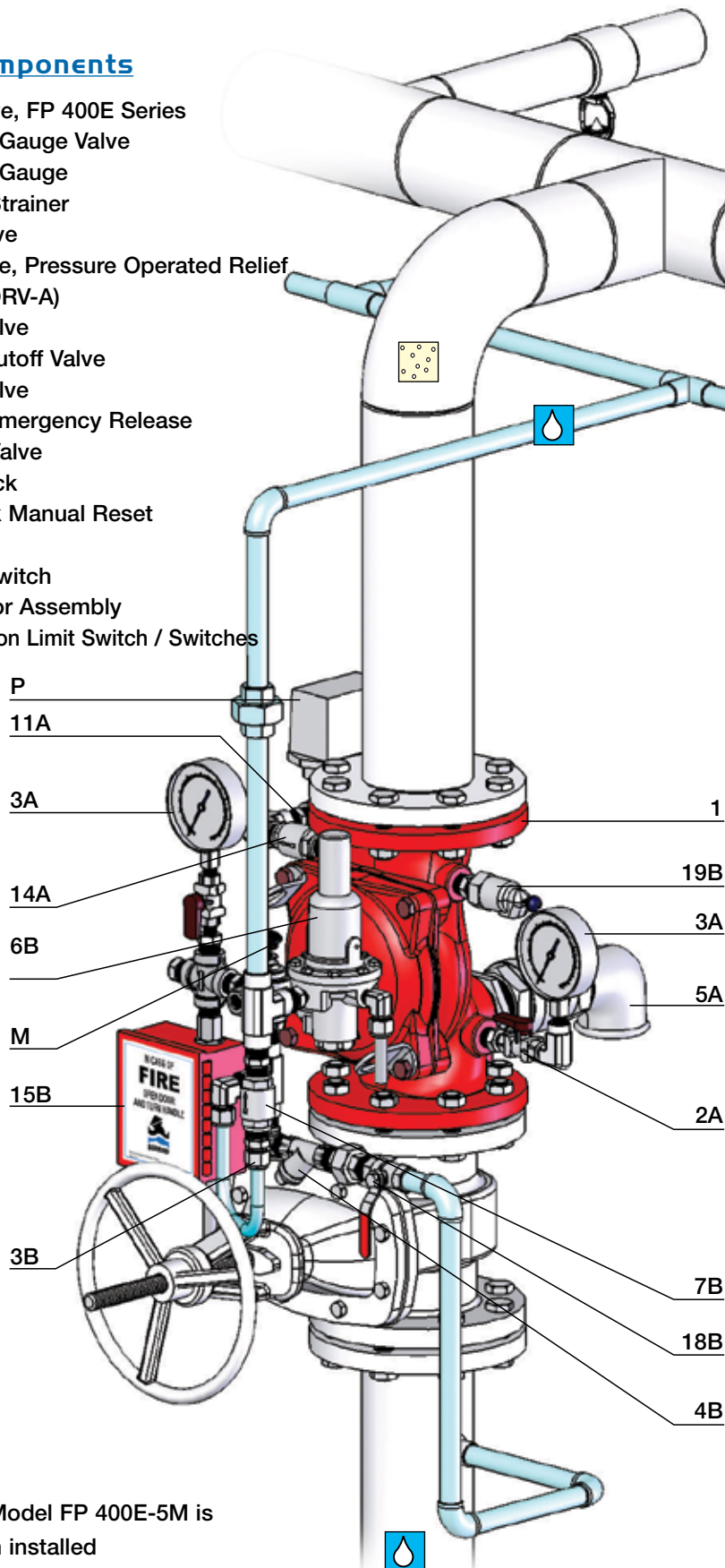
- 1 - Main Valve, FP 400E Series
 - 2A - Pressure Gauge Valve
 - 3A - Pressure Gauge
 - 4B - Priming Strainer
 - 5A - Drain Valve
 - 6B - Adjustable, Pressure Operated Relief Valve (PORV-A)
 - 7B - Check Valve
 - 11A - Alarm Shutoff Valve
 - 14A - Check Valve
 - 15B - Manual Emergency Release
 - 18B - Priming Valve
 - 19B - Drip Check
 - M - EasyLock Manual Reset
- Optional**
- P - Pressure Switch
 - W - Water Motor Assembly
 - S - Valve Position Limit Switch / Switches



-  Hydraulic
-  Atmosphere

UL Listed

The BERMAD Model FP 400E-5M is UL-Listed when installed with specific components and accessories.



BERMAD Fire Protection

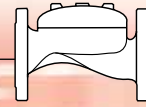

Model: FP 400E-5M

400 Series

Technical Data

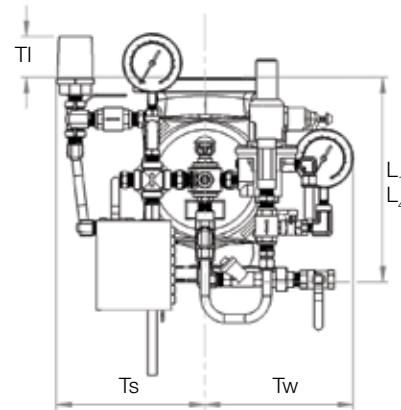
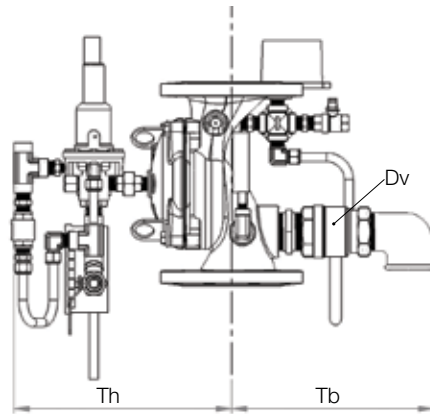

Size	1½", 2"		2½"		3"		4"		6"		8"		10"		12"		
	mm	inch	mm	inch	mm	inch	mm	inch	mm	inch	mm	inch	mm	inch	mm	inch	
Dimensions	L ₁ ⁽¹⁾	205	8 1/16	205	8 1/16	257	10 1/8	320	12 5/8	415	16 5/16	500	19 11/16	605	23 13/16	725	28 9/16
	L ₄ ⁽²⁾	205	8 1/16	N/A	N/A	250	9 13/16	320	12 5/8	415	16 5/16	500	19 11/16	N/A	N/A	N/A	N/A
	TI	142	5 5/8	142	5 5/8	119	4 11/16	84	3 5/16	57	2 1/4	-	-	-	-	-	-
	Tw	228	9	220	8 11/16	243	9 9/16	253	10	312	12 5/16	326	12 13/16	346	13 5/8	391	15 3/8
	Ts	228	9	220	8 11/16	243	9 9/16	253	10	318	12 1/2	326	12 13/16	326	12 13/16	391	15 3/8
	Th	226	8 7/8	242	9 1/2	262	10 5/16	261	10 5/16	356	14	407	16	407	16	546	21 1/2
	Tb	278	10 1/16	289	11 3/8	300	11 13/16	337	13 1/4	378	14 7/8	405	15 15/16	413	16 1/4	473	18 5/8
Dv Ø	¾"		1 1/2"		1 1/2"		2"		2"		2"		2"		2"		

- Notes:**
- L₁ is for flanged ANSI #150 and ISO PN16.
 - L₄ is for grooved end connections (Ductile Iron Only).
 - Provide adequate space around valve for maintenance.
 - Data is for envelope dimensions, specific component positioning may vary.

Connection Standard

- Flanged: ANSI B16.42 (Ductile Iron), B16.5 (Steel & Stainless Steel), B16.24 (Bronze) or ISO PN16
- Grooved: ANSI/AWWA C606 for 2, 3, 4, 6 & 8"

Water Temperature

- 0.5 – 50°C (33 – 122°F)

Manufacturers Standard Materials

Main valve body and cover

- Ductile Iron ASTM A-536

Main valve internals

- Stainless Steel 304 & Cast Iron

Control Trim System

- Brass control components/accessories
- Stainless Steel 316 tubing & fittings

Elastomers

- Nylon fabric reinforced polyisoprene NR

Coating

- Electrostatic Powder Coating Polyester, Red (RAL 3002)

Available Sizes

- 1½, 2, 2½, 3, 4, 6, 8, 10 & 12"
- UL-Listed for sizes 1½, 2, 2½, 3, 4, 6, 8 & 10"

Pressure Rating

- Max. working pressure: 250 psi (17 bar)

PORV Setting

Valve opens on pilot line pressure drop

- Factory Set: 72 psi (5 bar)
 - Adjustable Range: 10-115 psi (0.7-8 bar)
- Warning:** The release point must be set at the maximum elevation of the highest wet pilot line release device above the main valve plus at least 10 psi (0.7 bar).

Optional Materials

Main valve body

- Carbon Steel ASTM A-216 WCB
- Stainless Steel 316
- Ni-Al-Bronze ASTM B-148

Control Trim

- Stainless Steel 316
- Monel® and Ni-Al-Bronze
- Hastalloy C-276

Elastomers

- NBR
- EPDM

Coating

- High Built Epoxy Fusion-Bonded with UV Protection, Anti-Corrosion



bermadfire@bermad.com • www.bermad.com

The information herein is subject to change without notice. BERMAD shall not be held liable for any errors. All rights reserved. © Copyright by BERMAD. PE4PE-5M 04