



Level and Flow Control Valve with Bi-Level Vertical Float

Model 757-66-U

- Reservoir level control
- Prioritizing consumers over reservoir filling
- Backup for reservoir supply valves
- Integral valve cavitation protection

The Model 757-66-U Level and Flow Control Valve with Bi-Level Vertical Float is a hydraulically operated, diaphragm actuated control valve that controls reservoir filling. The valve hydraulically opens at pre-set low level and shuts off at pre-set high level. During filling, it limits the flow to preset maximum, regardless of fluctuating upstream pressure or reservoir level.



Features and Benefits

- **Line pressure driven** – Independent operation
- **Bi-Level hydraulic float control**
 - On/Off service
 - Low cavitation damage
 - Reservoir inherent refreshing
- **Hydraulic flow sensor (downstream installation)**
 - No moving parts
 - No electronic components
 - Wide flow setting range
 - Cavitation damage protection
- **Double chamber design**
 - Moderated valve reaction
 - Protected diaphragm
- **External installation**
 - Easy access to valve and float
 - Easy level setting
- **In-line serviceable** – Easy maintenance
- **Flexible design** – Easy addition of features

Major Additional Features

- Closing surge prevention – **757-66-49-U**
- Hydraulic float backup – **757-66-65-U**
- Altitude pilot backup – **757-66-80-U**

See relevant BERMAD publications.



Operation

The Model 757-66-U is a float and pilot controlled valve.

The float [1] slides along the rod [2]. When the float reaches either the adjustable high [3] or low [4] level stoppers, it pushes the rod assembly up or pulls it down, switching the float pilot [5] position. When the float is between the adjustable stoppers, the main valve remains in its last position. The restriction [6] continuously allows flow from valve inlet into the upper control chamber [7]. The Pressure Reducing (PR) pilot [8], and the Hydraulic Relay Valve (HRV) [9], together control outflow from the upper control chamber. At high level, the float pilot applies pressure to the HRV control chamber closing it and causing the main valve to shut off. At low level, the HRV opens, leaving the PR pilot to modulate the main valve open according to orifice [10] upstream pressure. Should this pressure rise above pilot setting, the PR pilot throttles, causing the main valve to throttle closed. Orifice upstream pressure is reduced to pilot setting, limiting the flow. The one-way flow control needle valve [11] stabilizes the valve's reaction in hard regulation conditions, by restricting the flow out of the control chamber. The downstream cock valve [12] enables manual closing.

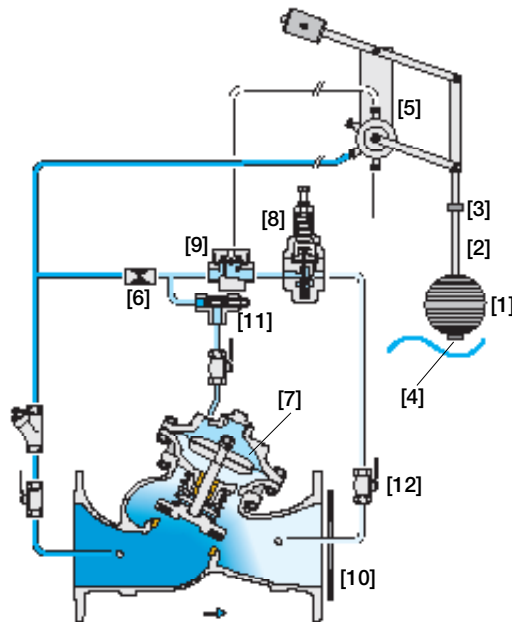

Low Level – Flow Control Mode

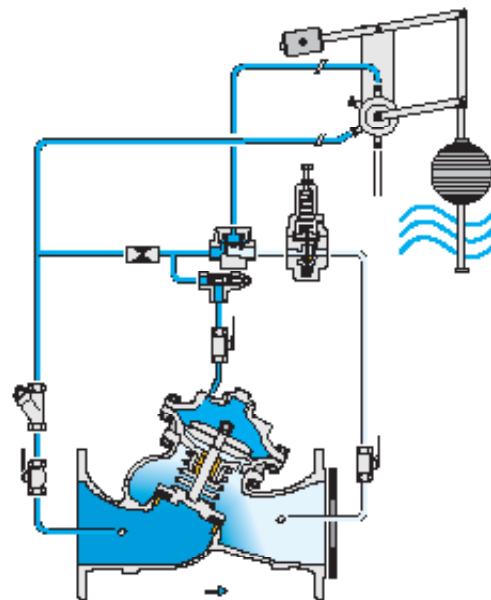

High Level – Valve Closed

Pilot System Specifications

Standard Materials:

Pilot:

Body: Stainless Steel 316 or Bronze

Elastomers: Synthetic Rubber

Spring: Stainless Steel

Float Pilot:

Body: Brass or Stainless Steel 316

Elastomers: Synthetic rubber

Internal parts: Stainless Steel 316 & Brass

Lever system: Brass or Stainless Steel 316

Float: Plastic

Float rod: Stainless Steel

Base plate: Fusion bonded epoxy coated Steel or

Stainless Steel 316

Tubing & Fittings:

Stainless Steel 316 or Copper & Brass

Accessories:

Stainless Steel 316, Brass and Synthetic

Rubber Elastomers

Pilot Adjustment Range:

0.5 to 3.0 bar ; 7 to 40 psi

0.8 to 6.5 bar ; 11 to 95 psi

1 to 16 bar ; 15 to 230 psi

Orifice Plate:

Standard material: Stainless Steel

O.D machined according to flange standard

I.D. machined according to required flow rate for optimal sizing and cavitation analysis

Notes:

- Minimum level differential: 15 cm (6")
- Maximum level differential: 54 cm (21")
- Each extension rod adds 56 cm (22"). One extension rod supplied
- Extra counterweight required if second extension rod used
- Recommended continuous flow velocity: 0.3-6.0 m/sec ; 1-20 ft/sec
- Inlet pressure, outlet pressure and flow rate are required
- See BERMAD float installation recommendations



Typical Applications

Gravity Fed Lines

Alternative solutions to accommodate the obvious pressure reducing requirements associated with high elevation differential pipelines are:

- Pressure-reducing valves in series (see BERMAD's publication: Proportional Pressure Reducing Valve, Model 720-PD)
- Sequential pressure breaking reservoirs

Where pressure breaking reservoirs already exist or are specified, some issues to consider are:

- Pipeline problems associated with line emptying and filling
- Valve cavitation damage
- Reservoir high pressure flow jets

The Model 757-66-U is well suited to provide the solutions to these issues.

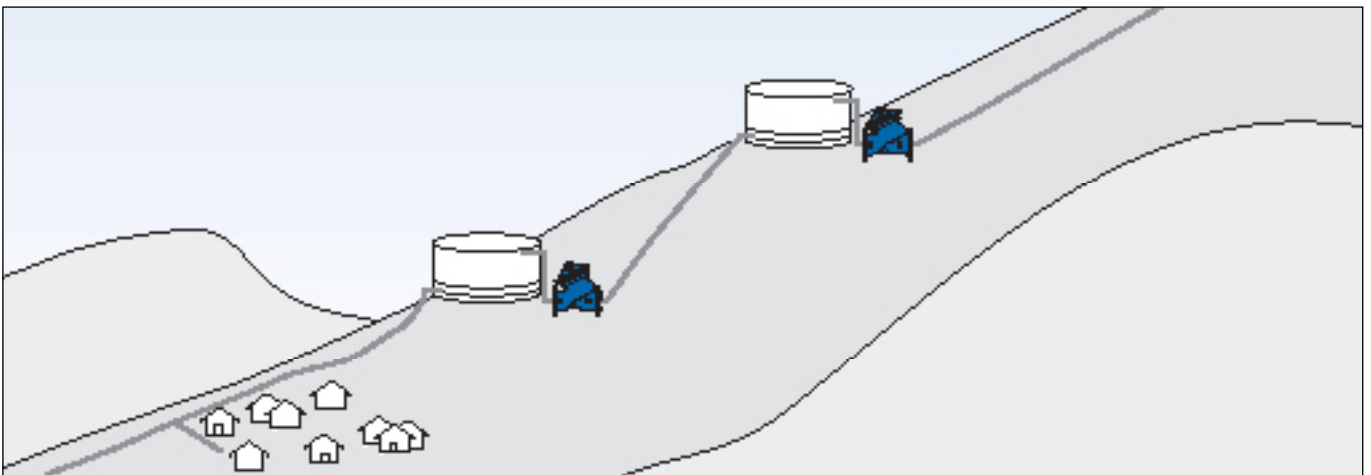

Typical Installation

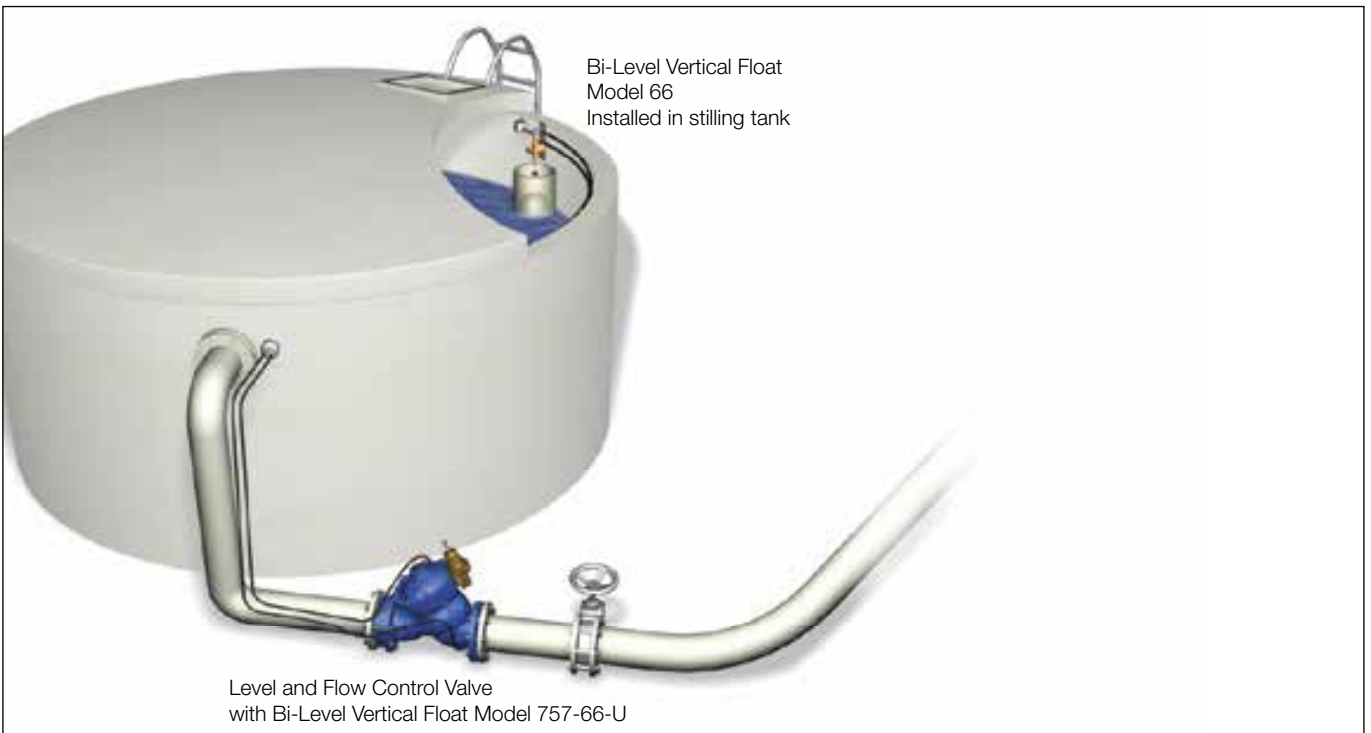



Technical Data

Size Range: DN40-900 ; 1 1/2-36"

End Connections (Pressure Ratings):

Flanged: ISO PN16, PN25 (ANSI Class 150, 300)

Threaded: BSP or NPT

Others: Available on request

Valve Patterns: "Y" (globe) & angle, globe (DN600-900 ; 24"-36")

Working Temperature: Water up to 80°C ; 180°F

Standard Materials:

Body & Actuator: Ductile Iron

Internals: Stainless Steel, Bronze & coated Steel

Diaphragm: Synthetic Rubber Nylon fabric-reinforced

Seals: Synthetic Rubber

Coating: Fusion Bonded Epoxy, RAL 5005 (Blue) approved for drinking water or Electrostatic Polyester Powder

Differential Pressure Calculation

$$\Delta P = \left(\frac{Q}{Kv; Cv} \right)^2$$

ΔP = Differential Pressure for fully open valve (bar; psi)

Q = Flow rate (m³/h; gpm)

Kv = Metric system - valve flow coefficient
(flow in m³/h at 1 bar ΔP with 15°C water)

Cv = US system - Valve flow coefficient
(flow in gpm at 1 psi ΔP with 60°F water)

$$Cv = 1.155 Kv$$

Flow Data & Dimensions Table

DN / Size		40	1.5"	50	2"	65	2.5"	80	3"	100	4"	150	6"	200	8"	250	10"	300	12"	350	14"	400	16"	450	18"	500	20"		
Flow Data	700 & 700ES	Kv / Cv - Flat																											
	700 & 700EN	Kv / Cv - V-Port																											
	700 & 700EN	Kv / Cv - "Y" Flat																											
700-ES	PN16; 25	Kv / Cv - "Y" V-Port																											
	PN16; 25	L (mm / inch)																											
		W (mm / inch)																											
		h (mm / inch)																											
		H (mm / inch)																											
Weight (Kg/lb)																													
700-EN	PN16; 25	L (mm / inch)																											
	PN16; 25	W (mm / inch)																											
		h (mm / inch)																											
		H (mm / inch)																											
		Weight (Kg/lb)																											
700 Flanged	"Y" PN16 Class 150	L (mm / inch)																											
		W (mm / inch)																											
		h (mm / inch)																											
		H (mm / inch)																											
		Weight (Kg/lb)																											
	"Y" PN25 Class 300	L (mm / inch)																											
		W (mm / inch)																											
		h (mm / inch)																											
		H (mm / inch)																											
		Weight (Kg/lb)																											
700 Threaded	"Y" PN16; 25 Class 150; 300	L (mm / inch)																											
		W (mm / inch)																											
		h (mm / inch)																											
		H (mm / inch)																											
		Weight (Kg/lb)																											
	Angle PN16; 25 Class 150; 300	L (mm / inch)																											
		W (mm / inch)																											
		R (mm / inch)																											
		h (mm / inch)																											
		H (mm / inch)																											

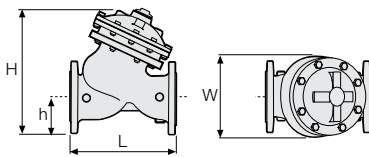

Specify when ordering:

- Size
- Main model
- Additional features
- Pattern
- Body material
- End connection
- Coating
- Voltage & main valve position
- Tubing & Fittings materials
- Operational data (according to model)
- Pressure data
- Flow data
- Reservoir level data
- Settings

* Use Bermad's Waterworks Ordering Guide

DN / Size		600	24"	700	28"	750	30"	800	32"	900	36"
Globe PN16 Class 150	L (mm / inch)	1,450	57.1	1,650	65	1,750	68.9	1,850	72.8	1,850	72.8
	W (mm / inch)	1,250	49.2	1,250	49.2	1,250	49.2	1,250	49.2	1,250	49.2
	h (mm / inch)	470	18.5	490	19.3	520	20.5	553	21.8	600	23.6
	H (mm / inch)	1,965	77.4	1,985	78.1	2,015	79.3	2,048	80.6	2,095	82.5
	Weight (Kg/lb)	3,250	7,150	3,700	8,140	3,900	8,580	4,100	9,020	4,250	9,350
Globe PN25 Class 300	L (mm / inch)	1,500	59.1	1,650	65	1,750	68.9	1,850	72.8	1,850	72.8
	W (mm / inch)	1,250	49.2	1,250	49.2	1,250	49.2	1,250	49.2	1,250	49.2
	h (mm / inch)	470	18.5	490	19.3	520	20.5	553	21.8	600	23.6
	H (mm / inch)	1,965	77.4	1,985	78.1	2,015	79.3	2,048	80.6	2,095	82.5
	Weight (Kg/lb)	3,500	7,700	3,700	8,140	3,900	8,580	4,100	9,020	4,250	9,370

