



## Pneumatic Pressure Control On-Off Deluge Valve

### Model FP 400Y - 4DC

The BERMAD model 400Y-4DC is an elastomeric hydraulic, line pressure operated, deluge valve, designed specifically for advanced fire protection systems and the latest industry standards.

The 400Y-4DC is activated by a relay valve, held closed by pneumatic pressure. Opening and closing of the deluge valve can be controlled remotely.

An integrated pressure control pilot valve ensures a stable and precise pre-set downstream water pressure.

The BERMAD 400Y-4DC is suitable for open-nozzle systems with a high pressure water supply. The pneumatic control makes it ideal for use in freezing environments and corrosive media.

The optional valve position indicator can include a limit switch suitable for Fire & Gas monitoring systems.



(for Illustration Only)

### Benefits and Features

#### ■ Safety and reliability

- Time-proven, simple, fail-safe actuation
- Single-piece, rugged, elastomeric diaphragm seal - VRSD technology
- Obstacle-free, uninterrupted flow path
- No mechanical moving parts
- Shuts off on remote command
- Ensures precise, stable downstream water pressure
- Valve position limit switches (optional)

#### ■ High performance

- Very high flow efficiency
- Straight-through-flow Y-type body
- Approved for PN25 (365 psi)

#### ■ Designed for fire protection

- Face-to-face length standardized to ISO 5752, EN 558-1
- Suitable for corrosive fluids and freezing temperatures: pneumatic relay valve
- Designed to meet the requirements of the industry standards

#### ■ Quick and easy maintenance

- In-line serviceable
- Fast and easy cover removal
- Swivel mounted drain valves\*

\* For 3" valves and larger

### Typical Applications

- Remote control water spray systems
- Foam applications
- Corrosive water supplies
- High pressure water supply
- Freezing conditions

### Approvals



UL-Listed  
Special System Water Control Valves, Deluge Type (VLFT)  
Sizes 1½" - 16"



Det Norske Veritas  
Type Approval



ABS  
American Bureau of Shipping  
Type Approval



Lloyd's Register  
Type Approval

### Additional Options

- Valve position limit switches
- Alarm pressure switch
- Air maintenance device
- Sea water compatibility
- Drain valve/s inlet/outlet
- For "automatic activation" select BERMAD local or remote reset model

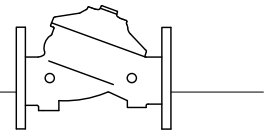

## Operation

(for Illustration Only)

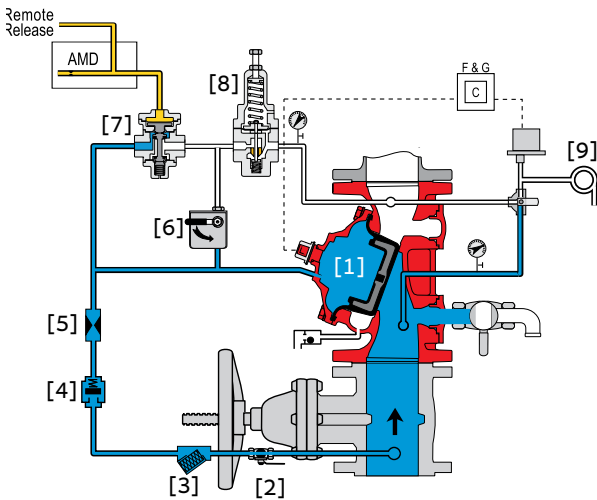

**Valve Closed** (normal conditions)

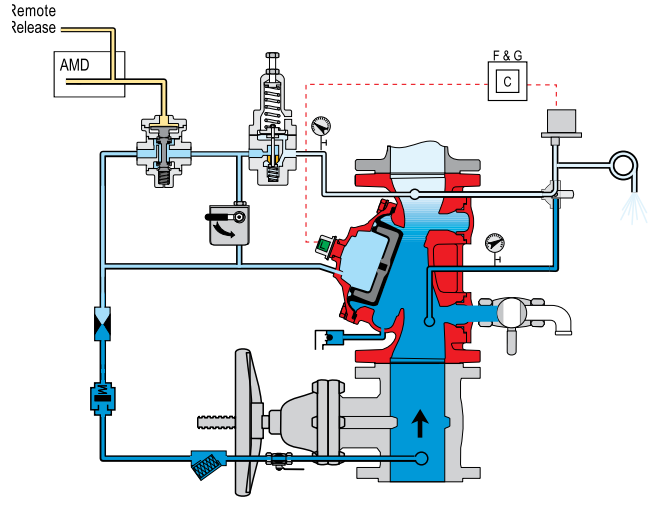

**Valve Open** (fire conditions)

The BERMAD model 400Y-4DC is held closed by water pressure in the control chamber [1]. Upon release of pressure from the control chamber, the valve opens.

Under NORMAL conditions, water pressure is supplied to the control chamber via the priming line [2] strainer [3] and restriction orifice [5], it is then trapped in the control chamber by a check valve [4], manual emergency release [6], and a relay valve (URV) [7] that is held closed by pneumatic pressure in the dry pilot line [E]. The water pressure trapped in the main valve control chamber holds the diaphragm against the valve seat, sealing it drip-tight and keeping the system pipes dry.

Under FIRE conditions, water pressure is released from the control chamber, either with the manual emergency release, or by the URV opening in response to a decrease in pneumatic pilot-line pressure. This opens the 400Y-4DC deluge valve, allowing water to flow into the system piping and to the alarm device [9]. The pressure-reducing pilot valve [8] senses changes in outlet pressure and, modulates the main valve to maintain the set downstream pressure.

When outlet pressure changes, the pressure-reducing pilot opens or closes in response. This regulates the pressure in the main valve's control chamber, thus modulating the position of the diaphragm seal disk to maintain the set downstream pressure.

## System P&ID

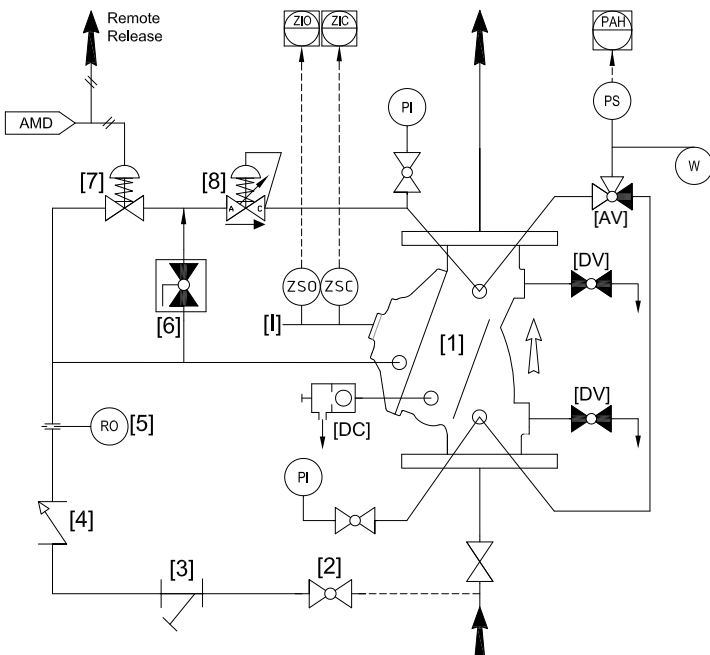

### Components

- 1 BERMAD 400Y Deluge Valve
- 2 Priming Ball Valve
- 3 Priming Strainer
- 4 Check valve
- 5 Restriction Orifice
- 6 Manual Emergency Release
- 7 URV-2 Hydraulic Relay Valve
- 8 Pressure Control Pilot Valve

### Optional System Items\*

- PI Pressure Gauge
- I Valve Position Indicator
- DC Drip Check
- AV 3-Way Alarm Test Valve
- DV Drain Valve
- PS Pressure Switch
- ZS Limit Switch Assembly
- W Water Motor Alarm
- AMD Air Maintenance Device

\* See also Factory Fitted Options under the Valve Code Designations on the last page



## System Installation

A typical installation of the BERMAD model 400Y-4DC features actuation by way of a fall in pneumatic pressure to the control chamber of the 2-Way Universal Relay Valve. When open, and fitted with a limit switch the valve can send a feedback signal to a remote valve position monitoring system.

A pressure reducing pilot valve integrated in the control trim ensures a precise and stable pre-set downstream water pressure.

## Optional System Items

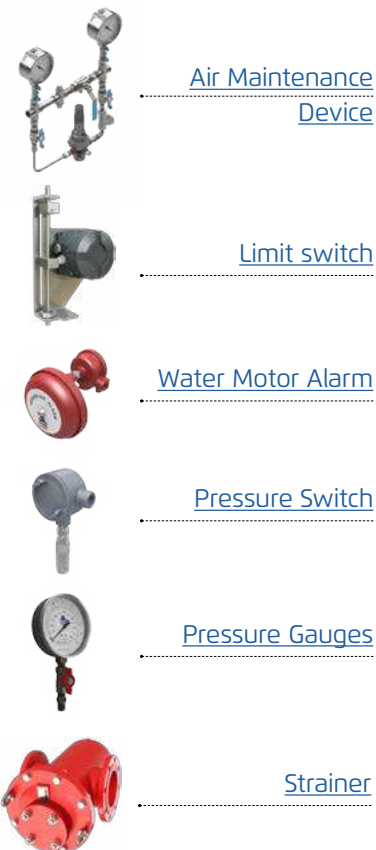

(for Illustration Only)

## Suggested Specifications:

The deluge valve shall be UL listed, 25 bar/365 psi rated, elastomeric-type, with a straight-through, Y-type body. The valve shall have an unobstructed flow path, with no stem guide or supporting ribs.

Valve actuation shall be accomplished by a single-piece, rolling diaphragm bonded with a rugged radial seal disk. The diaphragm assembly shall be the only moving part.

The deluge valve shall include a relay pilot valve, a pressure reducing pilot valve, a Y-type strainer, a ball drain valve, an automatic drip-check with manual override, 4-inch pressure gauges, and a manual emergency release housed in a stainless steel box. The valve drain socket shall be flanged and have 360-degree swivel.

The valve shall be equipped with two limit switches.

Removing the valve cover for inspection and maintenance shall not require removing the control trim.

The deluge valve and its entire control trim shall be supplied pre-assembled and hydraulically tested by a factory certified to ISO 9000 and 9001 standards.

# BERMAD Fire Protection

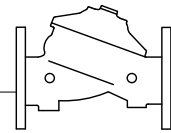

Model FP 400Y - 4DC

400Y Series

## Technical Data

### Available Sizes (inch)

- Flanged - 1½, 2, 3, 4, 6, 8, 10, 12, 14 & 16"
- Grooved - 1½, 2, 3, 4, 6 & 8"
- Threaded - 1½ & 2"

### Pressure Rating

- ANSI#150 - 16 bar / 235 psi
- ANSI#300 - 1½" to 10" 25 bar / 365 psi  
12" to 16" 20 bar / 300 psi
- Grooved - 25 bar / 365 psi
- Threaded - 25 bar / 365 psi
- Setting range: 4 - 12 bar (60 - 175 psi)

### Elastomer

- HTNR - Fabric Reinforced High Temperature Compound - See 400Y Engineering

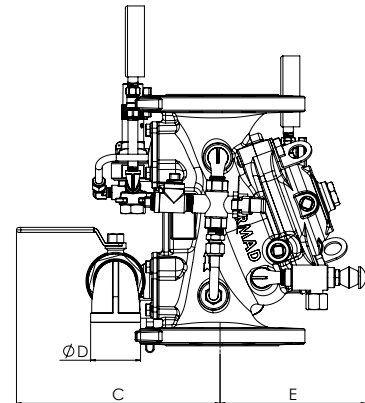
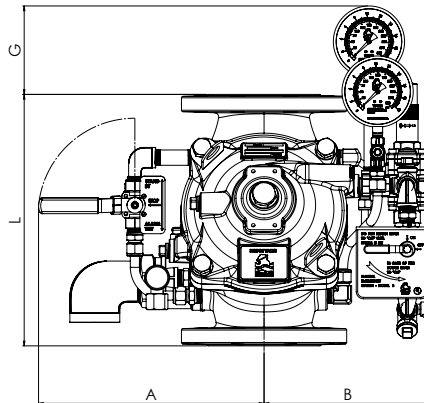

Valve Size	1½" DN40		2" DN50		3" DN80		4" DN100		6" DN150		8" DN200		10" DN250		12" DN300		14" DN350		16" DN400	
	mm	in	mm	in	mm	in	mm	in	mm	in	mm	in	mm	in	mm	in	mm	in	mm	in
<sup>(1)</sup> L ANSI #150	230	9.1	230	9.1	310	12.2	350	13.8	480	18.9	600	23.6	730	28.7	850	33.5	980	38.6	1100	43.3
<sup>(2)</sup> L ANSI #300	230	9.1	235	9.3	326	12.8	368	14.5	506	19.9	626	24.7	730	28.8	850	33.5	980	38.6	1100	43.3
A	320	12.6	320	12.6	380	15.0	388	15.3	441	17.4	471	18.5	471	18.5	584	23.0	584	23.0	584	23.0
B	164	6.5	164	6.5	222	8.7	232	9.1	287	11.3	365	14.4	365	14.4	428	16.9	428	16.9	428	16.9
C	241	9.5	241	9.5	274	10.8	290	11.4	305	12.0	320	12.6	320	12.6	383	15.1	383	15.1	408	16.1
ØD	¾"		¾"		1½"		2"		2"		2"		2"		2"		2"		2"	
E	180	7.1	180	7.1	185	7.3	195	7.7	228	9.0	295	11.6	295	11.6	441	17.4	441	17.4	415	16.3
F	142	5.6	142	5.6	132	5.2	119	4.7	71	2.8	46	1.8	-	-	-	-	-	-	-	-
<sup>(3)</sup> Kv / Cv	68 / 79		80 / 92		190 / 219		345 / 398		790 / 912		1160 / 1340		1355 / 1652		2600 / 3040		2950 / 3450		3254 / 3801	
<sup>(4)</sup> Leq(4): m / ft	2 / 7		6 / 18		8 / 25		9 / 31		15 / 49		28 / 92		64 / 209		46 / 149		56 / 184		90 / 295	
Kg / lb (ANSI # 150)	18 / 40		20 / 43		34 / 76		44 / 98		88 / 193		151 / 332		181 / 398		324 / 713		357 / 785		403 / 887	
Kg / lb (ANSI # 300)	20 / 45		22 / 48		35 / 77		51 / 113		108 / 238		171 / 376		217 / 477		364 / 801		429 / 944		523 / 1151	

<sup>(1)</sup> Refers to the length dimensions for Raised Face ANSI #150, ISO 16 Flanged, Threaded and Grooved valves

<sup>(2)</sup> Refers to the length dimensions for Raised Face ANSI #300 and ISO 25 Flanged valves

<sup>(3)</sup> Flow coefficients apply to a fully opened valve

<sup>(4)</sup> Leq (Equivalent Pipe Length) refers to turbulent flow in new steel pipe schedule 40 for a fully opened valve, values given for general consideration only

<sup>(5)</sup> **IMPORTANT:** Dimensions for the trim envelope or extents may vary with specific component positioning and where needed can be tailored to suit specific requirements - allow a tolerance of at least ±10%.

## Valve Code Designations

FP    6"    400Y 4DC    06-03    V    C    A5    PR    NN    N6nW

Category	code
Standard	FP
Seawater	FS
Foam Concentrate	FC

Valve Size	
1½"	40 mm
2"	50 mm
3"	80 mm
4"	100 mm
6"	150 mm
8"	200 mm
10"	250 mm
12"	300 mm
14"	350 mm
16"	400 mm

Speed and Pressure Control	Code
Differential Sensing Pilot	06
Opening speed	02
Closing speed	01
Opening & Closing speed	03
None	-

Installation	code
Vertical	V
Horizontal	H

Material Body & Cover <sup>(1)</sup>	code
Ductile Iron A356 <sup>(2)</sup>	C
Steel ASTM A216 WCB <sup>(2)</sup>	S
Stainless Steel 316	N
Nickel Al Bronze C95800	U
Super Duplex Grade 5A	D

End Connections	code
ANSI#150RF	A5
ANSI#150FF	a5
ANSI#300RF	A3
ISO PN16	16
ISO PN25	25
Grooved 235psi/PN16, ANSI C606	VI
Grooved 365psi/PN25, ANSI C606	V2
Threaded 235psi/PN16, ISO-7-Rp	BP
Threaded 365psi/PN25, ISO-7-Rp	PH
Threaded 235psi/PN16, NPT	NP
Threaded 365psi/PN25, NPT	NH

Coating	code
Polyester Red	PR
High Build Epoxy	ER
Uncoated	UC

Factory Fitted Options*	Code
General Purpose Pressure Switch	P
Ex Proof NEC, Div.1 Pressure Switch	P7
Ex d ATEX Pressure Switch	P9
Single Limit Switch, General Purpose	S
Single Ex d Proximity Limit Switch	S9
Double Ex d Proximity Limit Switch	SS9
Pressure Gauge Assembly	6
S.S Glycerin Pressure Gauge Assembly	6n
Monel Pressure Gauge Assembly	6m
Water Motor Alarm Assembly	W
Downstream Drain Valve	DV
Special Elastomer EPDM	E1
Special Elastomer NBR	E3
Large Control Filter	F
Valve Position Indicator	I
Stainless Steel 316 Trim Accessories	N
Stainless Steel 316 Seat	T
Pressure Transmitter	Q
Drain and Indicating Components	A

Tubing & Fittings	Code
Stainless Steel 316	NN
Monel 400	MM
Super Duplex	DD

\* For more Factory Fitted Options - see 400Y Ordering Guide or Consult BERMAD

### Notes:

<sup>(1)</sup> Other materials available see

[400Y Engineering](#)

<sup>(2)</sup> Coated internally and externally



[www.bermad.com](http://www.bermad.com)

The information contained herein may be changed by BERMAD without notice. BERMAD shall not be held liable for any errors.  
© Copyright 2009-2019 BERMAD CS Ltd. March 2019