

Level Control Valve

with Bi-Level Vertical Float

WW-750-66-B

- Reservoir filling
 - Very low supply pressure
 - Low noise generation
 - Energy cost critical systems
 - Systems with poor water quality
- Reservoir outlet
 - Distribution routing
 - Sewerage “fill and flush” systems

The Model 750-66-B Level Control Valve with Bi-Level Vertical Float is a hydraulically controlled, diaphragm actuated, double chambered control valve. The valve is hydraulically powered to fully open at pre-set reservoir low level, and to shut off at pre-set high level regardless of valve differential pressure.



Features and Benefits

- **Line pressure driven** – Independent operation
- **Bi-level hydraulic float control**
 - On/Off service
 - Low cavitation damage
 - Suitable for low quality water
 - Inherent reservoir refreshing
- **Double chamber**
 - Full powered opening and closing
 - Decreased pressure loss
 - No throttling noise
 - Non-slam closing characteristic
 - Protected diaphragm
- **External installation**
 - Easy access to valve and float
 - Easy level setting
 - Less wear and tear
- **Balanced seal disk** – High flow capacity
- **In-line serviceable** – Easy maintenance
- **Flexible design** – Easy addition of features

Major Additional Features

- Pressure sustaining – **753-66**
- Electric float backup – **750-66-65**
- Flow control – **757-66-U**
- Closing surge prevention – **750-66-49**
- Level sustaining – **75A-66**

See relevant BERMAD publications.

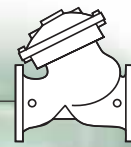

Operation

The Model 750-66-B is a float controlled valve equipped with a 4-Way, “last position”, bi-level float pilot assembly.

The float [1] slides along the rod [2]. When the float reaches either the adjustable high [3] or low [4] level stoppers, it either pulls the rod assembly down or pushes it up, switching the float pilot [5] position. When the float is between the adjustable stoppers, the main valve remains in its last position.

At high level, the float pilot applies pressure to the upper control chamber [6], and vents the lower control-chamber [7], powerfully shutting off the main valve.

At low level, the float pilot applies pressure to the lower control chamber, and vents the upper control chamber, powerfully opening the main valve.

For 10” valves and larger, two accelerators [8 & 9] quicken valve response.

Size range-1 1/2-8”

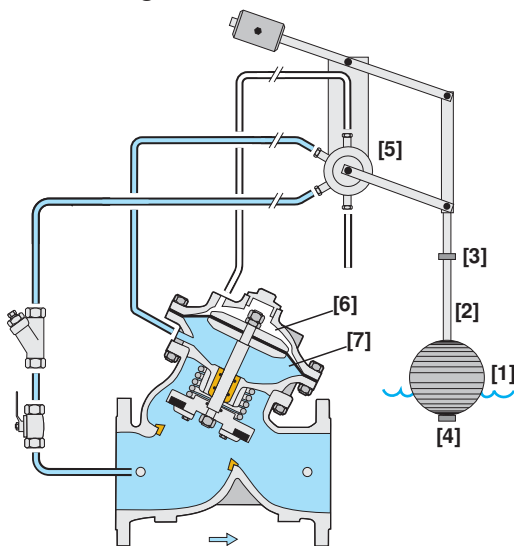

Size range-10-20”

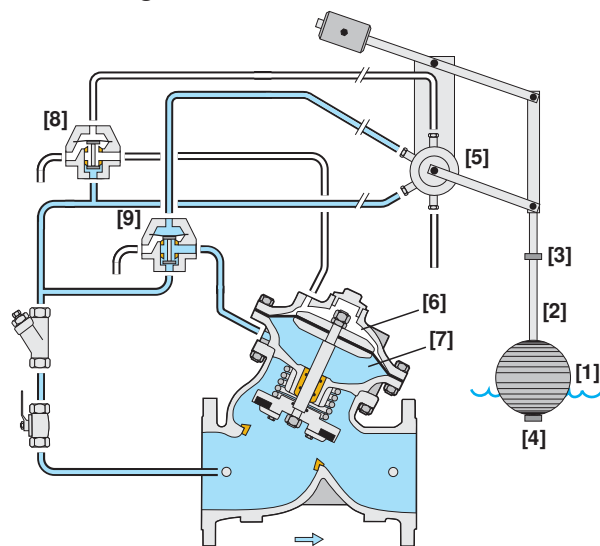

Engineer Specifications

The Level Control Valve shall be double chambered to power fully open at pre-set low level, and to shut off at pre-set high level regardless of valve differential pressure.

Main Valve: The main valve shall be a center guided, diaphragm actuated globe valve of either oblique (Y) or angle pattern design. The body shall have a replaceable, raised, stainless steel seat ring. The valve shall have an unobstructed flow path, with no stem guides, bearings, or supporting ribs. The body and cover shall be ductile iron. All external bolts, nuts, and studs shall be Duplex® coated. All valve components shall be accessible and serviceable without removing the valve from the pipeline.

Actuator: The actuator assembly shall be double chambered with an inherent separating partition between the lower surface of the diaphragm and the main valve. The entire actuator assembly (seal disk to top cover) shall be removable from the valve as an integral unit. The stainless steel valve shaft shall be center guided by a bearing in the separating partition. The replaceable radial seal disk shall include a resilient seal and shall be capable of accepting a V-Port Throttling Plug by bolting.

Control System: The control system shall consist of a 4-Way, “last position”, adjustable bi-level, hydraulic float pilot assembly, an isolating cock valve, (for 10” valves and larger: two accelerators), and a filter. All fittings shall be forged brass or stainless steel. The assembled valve shall be hydraulically tested.

Quality Assurance: The valve manufacturer shall be certified according to the ISO 9001 Quality Assurance Standard. The main valve shall be certified as a complete drinking water valve according to NSF, WRAS, and other recognized standards.



Typical Applications

Infrastructure Reservoirs

Optimal design of reservoir systems requires specifying a level control valve that reduces pumping costs by minimizing the extra pumping pressure required to operate standard valves.

Even at very low pressure, the Model 750-66-B ensures full opening, maximum flow capacity, and secure closing. It should be included during the system design phase or with changing needs.

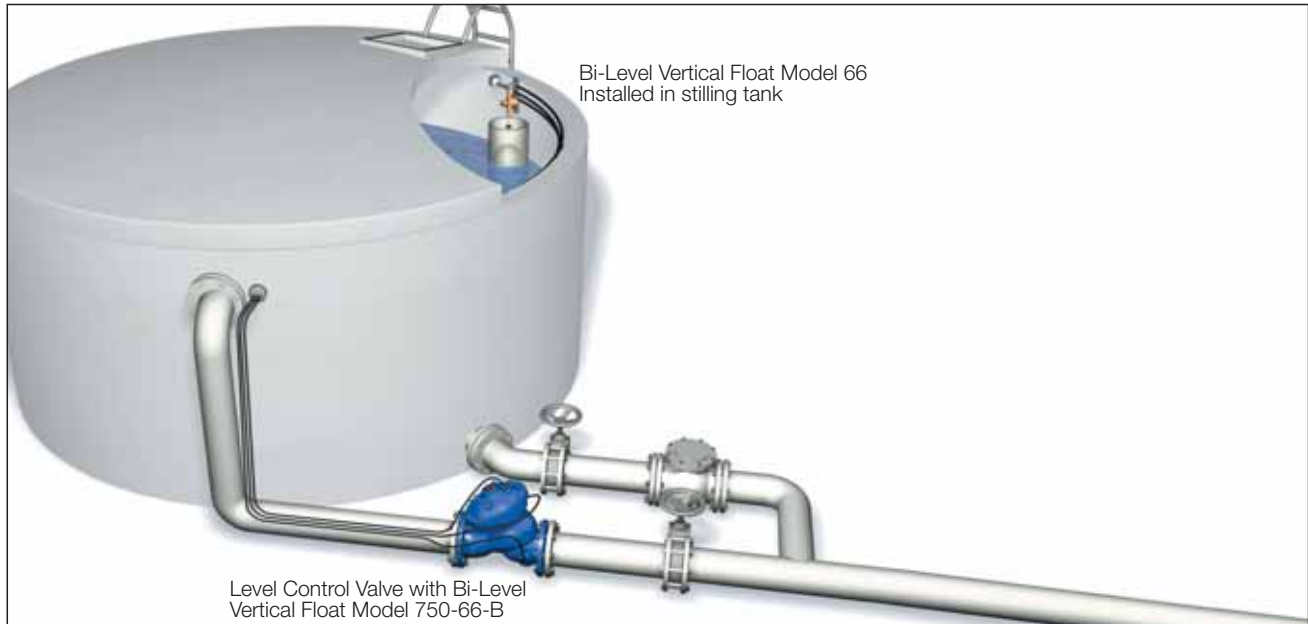

Pumping to Uphill Reservoir

In a reservoir system where a **pump provides pressure**, consumers are prioritized over reservoir filling by installing the **Model 753-66** Level Control and Pressure Sustaining Valve.

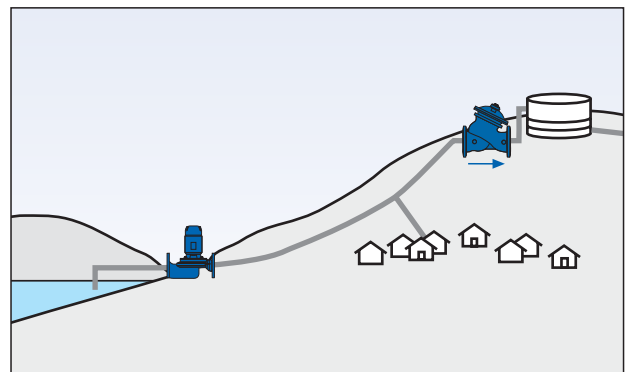

Gravity Filling a Downhill Reservoir

Where a **reservoir provides pressure** to consumers and fills a low lying reservoir, the consumers should be prioritized over filling the lower reservoir.

Defining the pressure set point for the standard level control and pressure sustaining valve is usually impossible, as there is only a very small potential differential pressure to operate the valve.

The solution: Rather than controlling the pressure during filling, control the filling flow ensuring sufficient pressure for consumers.

Install the **Model 757-66-U** Level and Flow Control Valve.

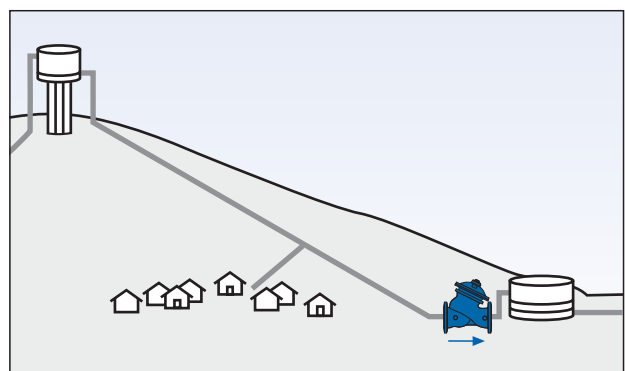

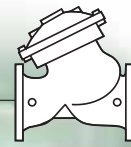

WW-750-66-B

For full technical details, refer to Engineering Section.

WW-700 Series

Reservoirs

Technical Data

Dimensions and Weights

Size		A, B		C		L		H		Weight	
mm	inch	mm	inch	mm	inch	mm	inch	mm	inch	kg	lbs
40	1 1/2"	350	14	180	7	205	8.1	239	9.4	9.1	20
50	2	350	14	180	7	210	8.3	244	9.6	10.6	23
65	2 1/2"	350	14	180	7	222	8.7	257	10.1	13	29
80	3"	370	15	230	9	250	9.8	305	12.0	22	49
100	4"	395	16	275	11	320	12.6	366	14.4	37	82
150	6"	430	17	385	15	415	16.3	492	19.4	75	165
200	8"	475	19	460	18	500	19.7	584	23.0	125	276
250	10"	520	21	580	23	605	23.8	724	28.5	217	478
300	12"	545	22	685	27	725	28.5	840	33.1	370	816
350	14"	545	22	685	27	733	28.9	866	34.1	381	840
400	16"	645	26	965	38	990	39.0	1108	43.6	846	1865
450	18"	645	26	965	38	1000	39.4	1127	44.4	945	2083
500	20"	645	26	965	38	1100	43.3	1167	45.9	962	2121

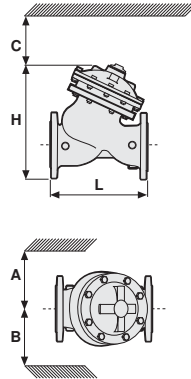

Data is for Y-pattern, flanged, PN16 valves
 Weight is for PN16 basic valves
 "C" enables removing the actuator in one unit
 "L", ISO standard lengths available
 For more dimensions and weights tables, refer to Engineering Section

Flow Chart

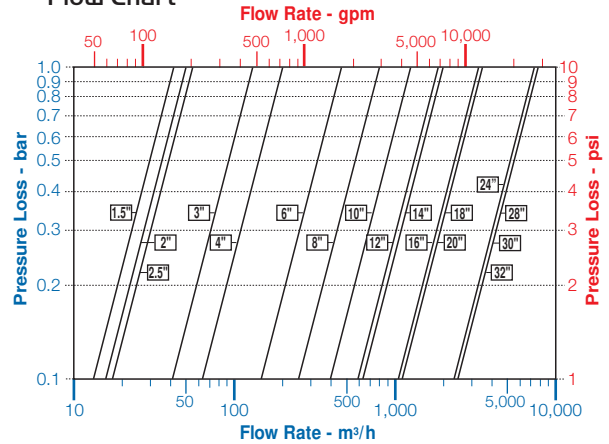

Data is for Y-pattern, flat disk valves
 For more flow charts, refer to Engineering Section

Main Valve

- Valve Patterns:** "Y" (globe) & angle
- Size Range:** 1 1/2"-32" (40-800 mm)
- End Connections (Pressure Ratings):** Flanged: ISO PN16, PN25 (ANSI Class 150, 300)
- Threaded:** BSP or NPT
- Others:** Available on request
- Working Temperature:** Water up to 80°C (180°F)
- Standard Materials:** Body & Actuator: Ductile Iron
- Internals:** Stainless Steel, Bronze & coated Steel
- Diaphragm:** NBR Nylon fabric-reinforced
- Seals:** NBR
- Coating:** Fusion Bonded Epoxy, RAL 5005 (Blue) NSF & WRAS approved or Electrostatic Polyester Powder, RAL 6017 (Green)

Control System

- Standard Materials:** Accessories: Bronze, Brass, Stainless Steel & NBR
- Tubing:** Copper or Stainless Steel
- Fittings:** Forged Brass or Stainless Steel
- Float Standard Materials:** Pilot body: Brass
- Seals:** NBR
- Internals:** Stainless Steel & Brass
- Lever system:** Brass
- Float:** Plastic
- Float rod:** Stainless Steel
- Base plate:** Fusion bonded epoxy coated Steel
- Optional materials:** Stainless Steel metal parts and float, FPM (Viton®) seals

- Minimum level differential: 15 cm (6")
- Maximum level differential: 54 cm (21")
- Each extension rod adds 56 cm (22"), one extension rod supplied
- Extra counterweight required if second extension rod used
- See BERMAD float installation recommendations
- If inlet pressure is below 0.7 bar (10 psi) or above 10 bar (150 psi), consult factory

How to Order

Please specify the requested valve in the following sequence: (for more options, refer to Ordering Guide)

Sector	Size	Primary Feature	Additional Feature	Pattern	Body Material	End Connections	Coating	Voltage & Position	Tubing & Fittings	Additional Attributes
WW	6"	750	66	Y	C	16	EB	-	CB	BVI
Waterworks	1 1/2 - 32"	Level Control	Oblique (up to 20") Angle (up to 18") Globe (24-32" only)	Y A G	Epoxy FB Blue Polyester Green Polyester Blue Uncoated	EB PG PB UC	Copper Tubing & Brass Fittings Plastic Tubing & Brass Fittings St. St. 316 Tubing & Fittings	CB PB NN	Double Chambered Valve Position Indicator Large Control Filter V-Port Throttling Plug Orifice Assembly Electric Limit Switch St. St. 316 Control Accessories St. St. 316 Internal Trim (Closure & Seat) St. St. 316 Actuator Internal Assembly Delrin Bearing Viton Elastomers for Seals & Diaphragm	B I F V U S N T D R E
Closing Surge Prevention		49	Ductile Iron Standard	C						
Modulating Horizontal Float		60	Cast Steel	S						
Bi-Level Electric Float		65	St. Steel 316	N						
Bi-Level Vertical Float		66	Nickel Alumin. Bronze	U						
Modulating Vertical Float		67	ISO-16	16						
Altitude Pilot		80	ISO-25	25						
Modulating Altitude Pilot		82	ANSI-150	A5	24VAC/50Hz - N.C. 24VAC/50Hz - N.O. 24VDC - N.C. 24VDC - N.O. 24VDC - L.P. 220VAC/50-60Hz N.C. 220VAC/50-60Hz N.O.	4AC 4AO 4DC 4DO 4DP 2AC 2AO				
Sustaining Altitude Pilot		83	ANSI-300	A3						
Bi-Level Altitude Control		86	JIS-16	J6						
2-14 Meter Setting Altitude Pilot		M6	JIS-20	J2						
5-22 Meter Setting Altitude Pilot		M5								
15-35 Meter Setting Altitude Pilot		M4								
25-70 Meter Setting Altitude Pilot		M8								
Multiple choices permitted										

