

Sizes: 2"-12"; DN50-300

Description

The Turbo-IR-A Water Meter is ideal for borehole, irrigation and dirty water applications. Its "paddle-wheel" internal design allows water with up to 30% debris to pass through the water meter without loss of accuracy or damage to the meter.

Features

- The Bermad's Turbo-IR-A water meter equipped with Magnetic drive register with hermetic vacuum seal.
- Can be pre- equipped with a pulse output (reed switch) for batching or linking to remote monitoring equipment.
- One single measuring element assembly fits to all sizes (when without the register), can be removed for maintenance and /or replaced without removing the meter housing from the line.
- Can be installed in any orientation without interfering with metrological performance.
- All water meters are factory-calibrated.
- The Turbo-IR-A water meter has a long life and is easy to maintain at low cost.
- The Turbo-IR-A water meter can be equipped with two different types of registers.
 - Register with mechanical display.
 - Register with digital display.

Installation

- Confirm that the water meter arrow direction is in the flow direction.
- For future maintenance, install isolation valves upstream and downstream, from the water meter.
- All water meters must be installed in a straight pipe – having the same diameter as the nominal diameter of the water meter - acting as flow strengtheners, Upstream and downstream from the meter at the following length:
 - Upstream – 10 times line diameter
 - Downstream –5 times line diameter.
- Prior to installation, the pipe must be flushed to remove any debris or foreign matter.
- The water meter must be completely filled with water during use.
- Water back-flow will result in invalid metering. If there is any risk of water back-flow, Install a quick-acting (mechanical) check valve.
- Read switch wiring :
 - Black wire: common.
 - Red wire: pulse output #1. slow pulse.
 - White wire: pulse output #2. Fast pulse (**electronic register only**).

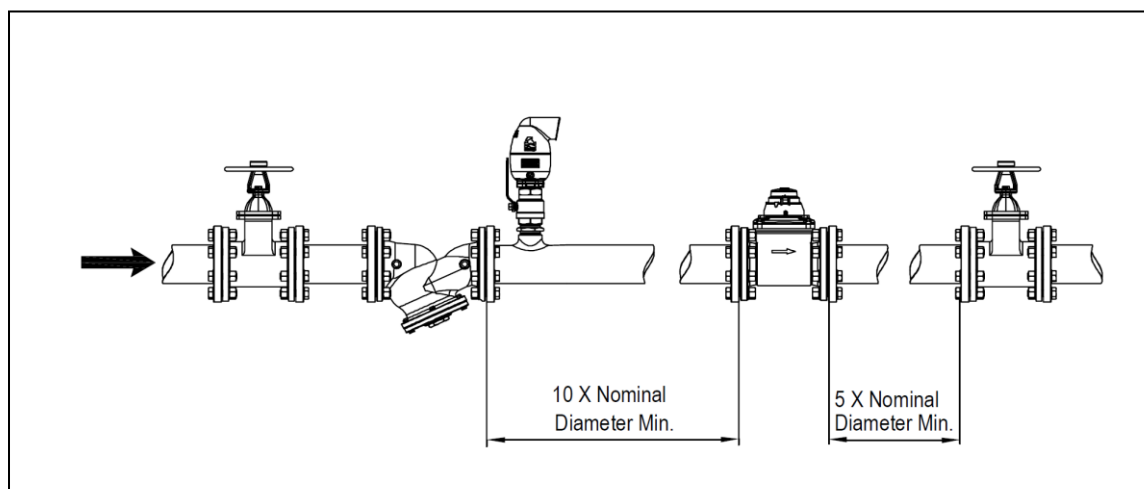

Operation

To ensure proper operating conditions, the quantity of water flowing through the water meter should correspond as closely as possible to its nominal capacity. Be aware of the maximum Working pressure and DO NOT exceed it!

DO NOT DISCONNECT OR OPEN THE WATER METER WHILE UNDER PRESSURE!

Note:

- Water meters require periodic recalibration according to the regulations of the local water board / water-management authority. Please refer to **Turbo-IR-A Accuracy Testing and Calibration Process**.
- We recommend that water meters be reconditioned at least every 5 years or at 300,000 (m³), 79,000,000 (gallon) after installation.

Trouble-Shooting

- **The pointers do not move, with water flowing:** Open the measuring element and check if there is debris, or a foreign object stuck in or around the paddle wheel.
- **There is no pulse output:** Check the wiring and confirm that the reed is correctly inserted.
- **There is leakage from the meter:** Check all screws are properly tightened and detect for cracked seals.

Maintenance

Preventative Maintenance

The purpose of preventive maintenance is to ensure efficient operation and long life by detecting and correcting any condition that may damage the meter or cause it to malfunction. Maintenance intervals are a function of the water quality and operating flows with which the Meter operates. Preventive maintenance includes periodic inspection, cleaning, and accuracy testing.

Periodic inspection

- Visually inspect the meter for missing hardware, loose bolts, broken or scratched register lens, or any other signs of wear or deterioration. Replace worn parts as required.
- Verify that the meter is operating at the proper flow rate and pressure. A loss in pressure coupled with a decrease in flow rate may indicate that the Upstream strainer's screen or the meter itself is clogged and needs cleaning.

Cleaning

- Clean all dirt, grease, moisture or other foreign matter from the meter's exterior. Use a cleaning solvent or volatile mineral spirits to remove grease or oil.
- To clean the measuring element, soak it for 12 hours in a mild soap-based cleaner or detergent, and then use a stiff bristle brush to remove any deposits. After cleaning, rinse thoroughly with water and dry.

Exploded View of Assembly

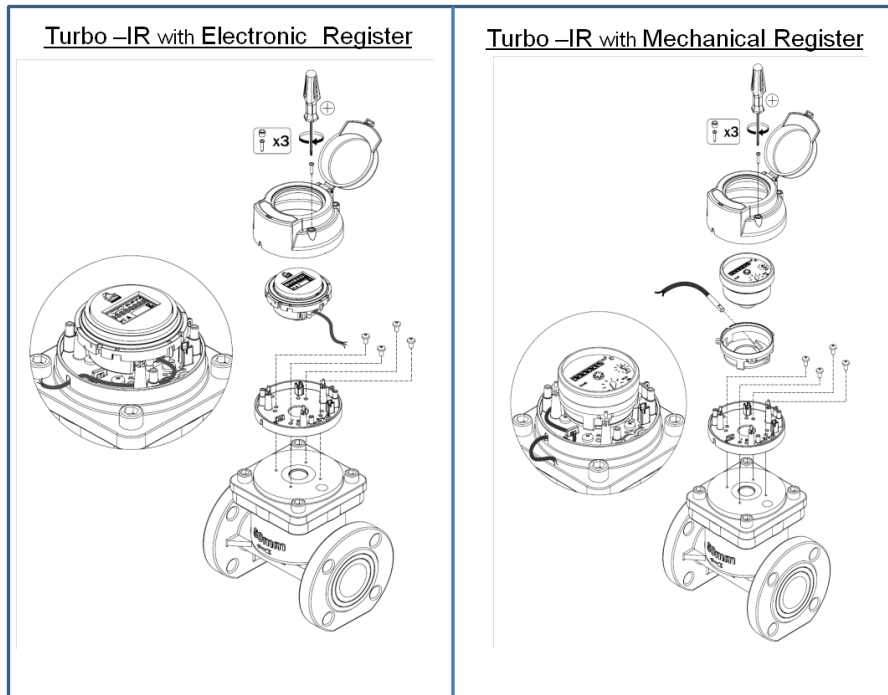

Pulse Options

Mechanical Pulse Options						
Models	Size		Single Pulse, Metric Display			
	Inch	mm	100 liter	1m ³	10m ³	100m ³
Turbo-IR-M , Turbo-Bar-M	1½-5	40-125	V	V	N/A	N/A
	6-8	150-200	N/A	V	V	N/A
	10-12	250-300	N/A	N/A	V	V
Turbo-Bar-M	14-20	350-500	N/A	N/A	V	V
Mechanical Pulse Options (Gallon Display)						
Models	Size		Single Pulse, Gallon Display			
	Inch	mm	10 GAL	100GAL	1000 GAL	10000 GAL
Turbo-IR-M , Turbo-Bar-M	1½-5	40-125	V	V	N/A	N/A
	6-8	150-200	N/A	V	V	N/A
	10-12	250-300	N/A	N/A	V	V
Turbo-Bar-M	14-20	350-500	N/A	N/A	V	V
Note: Dual Pulses Available According to Sign V						
Electronic Pulse Options						
Models	Size		Single Pulse, Metric Display			
	Inch	mm	10 liter	100 liter	1m ³	10m ³
Turbo-IR-E , Turbo-Bar-E	1½-5	40-125	V	V	V	N/A
	6-8	150-200	V	V	V	V
	10-12	250-300	V	V	V	V
Turbo-Bar-E	14-20	350-500	V	V	V	V
Electronic Pulse Options (Gallon Display)						
Models	Size		Single Pulse, Gallon Display			
	Inch	mm	1 GAL	10 GAL	100 GAL	1000 GAL
Turbo-IR-E , Turbo-Bar-E	1½-5	40-125	V	V	V	N/A
	6-8	150-200	V	V	V	V
	10-12	250-300	N/A	V	V	V
Turbo-Bar-E	14-20	350-500	N/A	V	V	V
Note: All Electronic Register Supplied with Dual Pulses According to Bermad Standard.						

Pulses Technical Data

	Electronic Register	Mechanical Register
Switching voltage	35 (Vdc) max.	24 AC/DC max.
Switching current		0.01 max.