

## Mod. F

Vertical bladder tank with foam outside the bladder, 2014/68 UE PED certificate

### Standard characteristics

**Body Material:** Carbon Steel

**Manhole:** Ø18"

**Membrane material:** Neoprene hypalon

**Design pressure:** 12 barg

**Test Pressure:** 18 barg

**Maximum working pressure:** 12 barg

**External finish:** Epoxy Primer + Polyuretanic red coat  
RAL3000, Total DFT >120 µm

**Capacity:** From 200 to 10000 liters

**Foaming charge control:** With valves on different levels

**Tie rods and nuts in Stainless Steel**

**Mixer:** See dedicated page

**Suitable for seismic zone level 2b UBC - PGA 0,25 g**

### Approvals



### Optional

- > Manual pump
- > Ladder for manhole access
- > Vents control kit at mixer's height
- > Foaming charge control with visual level indicator
- > Base frame

### Notes

In case of inquiry and/or order specify the following datas:

- > Tank capacity, flow rate range, mixing percentage, flow direction, mixer's flange

### Available on Demand

- > Body Material: Other Material
- > Different Design Pressure
- > Capacity: 11000 liters or 12000 liters
- > Insulated tank
- > Coating: Other Painting Cycles
- > ASME Stamped
- > Designed for other seismic zone

For additional options or special versions contact FAS SpA

[www.fasspa.net](http://www.fasspa.net)

## Mod. F

Vertical bladder tank with foam outside the bladder, 2014/68 UE PED certificate

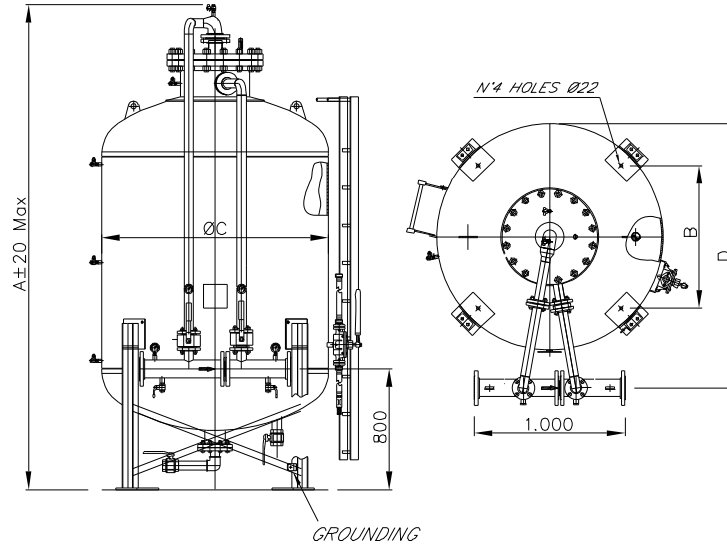

DESIGN DATA
CALCULATION RULES: DIRECTIVE "PED" - ASME VIII Div.1
DESIGN PRESSURE: 12 barg
WORKING PRESSURE: 12 barg Max
TEST PRESSURE: 18 barg
DESIGN TEMPERATURE: -29°C +80°C
JOINT EFFICIENCY: HEADS=1 - SHELL=0.85
CORROSION ALLOWANCE: NO
X RAYS: 10%
SEISMIC CLASSIFICATION:
ZONE 2 (ITALY) - ZONE 2b (UBC)
GROUND ACCELERATION: 0,225 g (MAX)

MODEL	A(mm)	B(mm)	ØC(mm)	D(mm)	CAPACITY	EMPTY WEIGHT	WORKING WEIGHT
F-6	2150	535	922	1160	600 l	640 Kg	1300 Kg
F-10	2750				1000 l	800 Kg	1900 Kg
F-15	2850	670	1112	1360	1500 l	940 Kg	2590 Kg
F-20	2765				2000 l	1000 Kg	3200 Kg
F-25	3115	850	1366	1585	2500 l	1150 Kg	3900 Kg
F-30	3415				3000 l	1210 Kg	4750 Kg
F-40	3370	1045	1630	1875	4000 l	1600 Kg	5760 Kg
F-50	3870				5000 l	1850 Kg	7035 Kg
F-60	3565	1190	1920	2210	6000 l	1960 Kg	8560 Kg
F-70	3915				7000 l	2250 Kg	9950 Kg
F-80	3895	1295	2074	2340	8000 l	2700 Kg	10970 Kg
F-90	4165				9000 l	2900 Kg	12800 Kg
F-100	4495				10000 l	3200 Kg	14200 Kg

Is reserved. No part of this drawing may be reproduced or transmitted in any form or by any means, without the prior consent in writing of F.A.S.  
 ite disegno è di proprietà F.A.S. E' VIETATO riprodurlo e falsificarlo.

## Mod. FI

Vertical bladder tank with foam inside the bladder, 2014/68 UE PED certificate

### Standard characteristics

**Body Material:** Carbon Steel

**Manhole:** Ø18"

**Membrane material:** Neoprene hypalon

**Design pressure:** 12 barg

**Test Pressure:** 18 barg

**Maximum working pressure:** 12 barg

**External finish:** Epoxy Primer + Polyuretanic red coat  
RAL3000, Total DFT >120 µm

**Capacity:** From 200 to 10000 liters

**Foaming charge control:** With visual level indicator

**Tie rods and nuts in Stainless Steel**

**Mixer:** See dedicated page

**Suitable for seismic zone level 2b UBC - PGA 0,25 g**

### Approvals



### Optional

- > Manual pump
- > Ladder for manhole access
- > Vents control kit at mixer's height
- > Foaming charge control with visual level indicator
- > Base frame

### Notes

In case of inquiry and/or order specify the following datas:

- > Tank capacity, flow rate range, mixing percentage, flow direction, mixer's flange

### Available on Demand

- > Body Material: Other Material
- > Different Design Pressure
- > Capacity: 11000 liters or 12000 liters
- > Insulated tank
- > Coating: Other Painting Cycles
- > ASME Stamped
- > Designed for other seismic zone

For additional options or special versions contact FAS SpA

[www.fasspa.net](http://www.fasspa.net)

## Mod. FI

Vertical bladder tank with foam inside the bladder, 2014/68 UE PED certificate

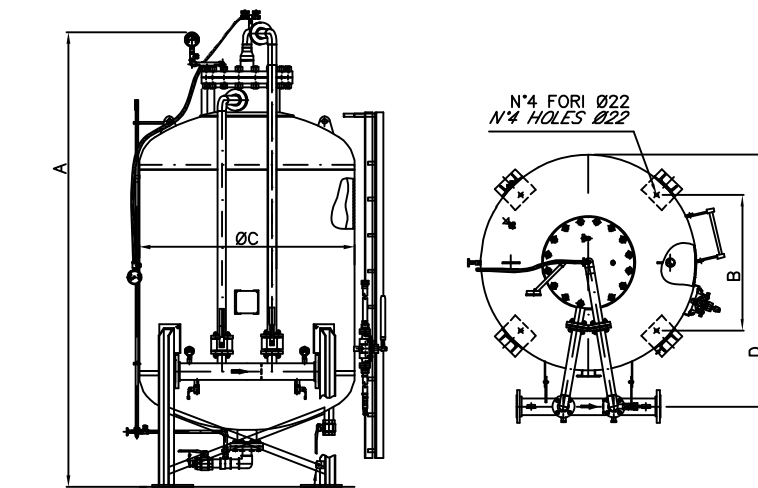

MESSA A TERRA  
GROUNDING

DATI DI PROGETTO	
DESIGN DATA	
NORME DI CALCOLO: DIRETTIVA "PED" ASME VIII Div.1	
CALCULATION RULES: DIRECTIVE "PED" ASME VIII Div.1	
PRESSIONE DI PROGETTO: 12 barg	
DESIGN PRESSURE: 12 barg	
PRESSIONE DI ESERCIZIO: 12 barg Max	
WORKING PRESSURE: 12 barg Max	
PRESSIONE DI PROVA: 18 barg	
TEST PRESSURE: 18 barg	
TEMPERATURA DI PROGETTO: -29°C +80°C	
DESIGN TEMPERATURE: -29°C +80°C	
EFFICIENZA GIUNTI: FONDI=1 FASCIAME=0.85	
JOINT EFFICIENCY: HEADS=1 - SHELL=0.85	
SOVRASPESORE DI CORROSIONE: NO	
CORROSION ALLOWANCE: NO	
RAGGI X: 10%	
X RAYS: 10%	
CLASSIFICAZIONE SISMICA:	
SEISMIC CLASSIFICATION:	
ZONA 2 (ITALIA) - ZONA 2b (UBC)	
ZONE 2 (ITALY) - ZONE 2b (UBC)	
ACCELERAZIONE AL SUOLO: 0,225 g (MAX)	
GROUND ACCELERATION: 0,225 g (MAX)	

MODELLO MODEL	A(mm)	B(mm)	ØC(mm)	D(mm)	CAPACITA' CAPACITY	PESO A VUOTO EMPTY WEIGHT	PESO IN ESERCIZIO WORKING WEIGHT
FI-6	2150	535	922	1160	600 l	640 Kg	1300 Kg
FI-10	2750				1000 l	800 Kg	1900 Kg
FI-15	2850	670	1112	1360	1500 l	940 Kg	2590 Kg
FI-20	2765	850	1366	1585	2000 l	1000 Kg	3200 Kg
FI-25	3115				2500 l	1150 Kg	3900 Kg
FI-30	3415				3000 l	1210 Kg	4750 Kg
FI-40	3370	1045	1630	1875	4000 l	1600 Kg	5760 Kg
FI-50	3870				5000 l	1850 Kg	7035 Kg
FI-60	3565	1190	1920	2210	6000 l	1960 Kg	8560 Kg
FI-70	3915				7000 l	2250 Kg	9950 Kg
FI-80	3895	1295	2074	2340	8000 l	2700 Kg	10970 Kg
FI-90	4165				9000 l	2900 Kg	12800 Kg
FI-100	4495				10000 l	3200 Kg	14200 Kg

All rights reserved. No part of this drawing may be reproduced or transmitted in any form or by any means, without the prior consent in writing of F.A.S.

Il presente disegno è di proprietà F.A.S. E' VIETATO riprodurlo e falsificarlo.



## Mod. Fx2

Vertical double bladder tank with foam outside the bladder, 2014/68 UE PED certificate

### Standard characteristics

**Body Material:** Carbon Steel

**Manhole:** Ø18"

**Membrane material:** Neoprene hypalon

**Design pressure:** 12 barg

**Test Pressure:** 18 barg

**Maximum working pressure:** 12 barg

**External finish:** Epoxy Primer + Polyuretanic red coat  
RAL3000, Total DFT >120 µm

**Capacity:** From 600 l (300x2) to 20000 l (10000x2)

**Foaming charge control:** With valves on different levels

**Tie rods and nuts in Stainless Steel**

**Mixer:** See dedicated page

**Suitable for seismic zone level 2b UBC - PGA 0,25 g**

### Approvals



### Optional

- > Manual pump
- > Ladder for manhole access
- > Vents control kit at mixer's height
- > Foaming charge control with visual level indicator
- > Base frame

### Notes

In case of inquiry and/or order specify the following datas:

- > Tank capacity, flow rate range, mixing percentage, flow direction, mixer's flange

### Available on Demand

- > Body Material: Other Material
- > Different Design Pressure
- > Capacity: 11000 liters or 12000 liters
- > Insulated tank
- > Coating: Other Painting Cycles
- > ASME Stamped
- > Designed for other seismic zone

For additional options or special versions contact FAS SpA

[www.fasspa.net](http://www.fasspa.net)

## Mod. Fx2

Vertical double bladder tank with foam outside the bladder, 2014/68 UE PED certificate

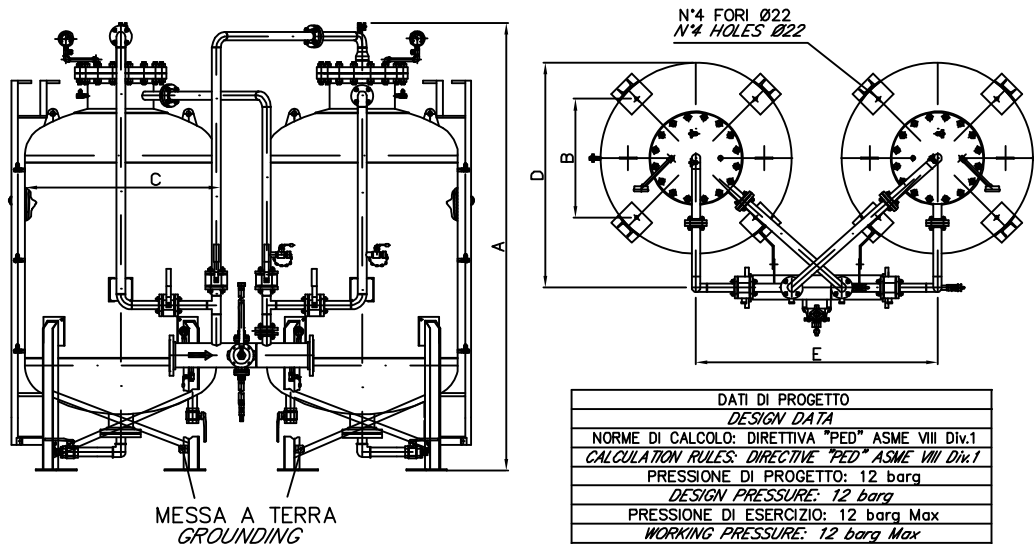

DATI DI PROGETTO	
DESIGN DATA	
NORME DI CALCOLO: DIRETTIVA "PED" ASME VIII Div.1	
CALCULATION RULES: DIRECTIVE "PED" ASME VIII Div.1	
PRESSIONE DI PROGETTO: 12 barg	
DESIGN PRESSURE: 12 barg	
PRESSIONE DI ESERCIZIO: 12 barg Max	
WORKING PRESSURE: 12 barg Max	
PRESSIONE DI PROVA: 18 barg	
TEST PRESSURE: 18 barg	
TEMPERATURA DI PROGETTO: -29°C +80°C	
DESIGN TEMPERATURE: -29°C +80°C	
EFFICIENZA GIUNTI: FONDI=1 FASCIAME=0.85	
JOINT EFFICIENCY: HEADS=1 - SHELL=0.85	
SOVRASPESORE DI CORROSIONE: NO	
CORROSION ALLOWANCE: NO	
RAGGI X: 10%	
X RAYS: 10%	
CLASSIFICAZIONE SISMICA:	
SEISMIC CLASSIFICATION:	
ZONA 2 (ITALIA) - ZONA 2b (UBC)	
ZONE 2 (ITALY) - ZONE 2b (UBC)	
ACCELERAZIONE AL SUOLO: 0,225 g (MAX)	
GROUND ACCELERATION: 0,225 g (MAX)	

MODELLO MODEL	A(mm)	B(mm)	ØC(mm)	D(mm)	E(mm)	CAPACITA' CAPACITY	PESO A VUOTO EMPTY WEIGHT	PESO IN ESERCIZIO WORKING WEIGHT
F-6x2	2135	535	922	1160	1380	1200 l	1280 Kg	2600 Kg
F-10x2	2735					2000 l	1600 Kg	3800 Kg
F-15x2	2835					3000 l	1880 Kg	5180 Kg
F-20x2	2745	850	1366	1585	1680	4000 l	2000 Kg	6400 Kg
F-25x2	3095					5000 l	2300 Kg	7800 Kg
F-30x2	3395					6000 l	2420 Kg	8920 Kg
F-40x2	3355	1045	1630	1875	1935	8000 l	3200 Kg	11520 Kg
F-50x2	3795					10000 l	3700 Kg	14070 Kg
F-60x2	3855					12000 l	3920 Kg	17120 Kg
F-70x2	3895	1190	1920	2210	2250	14000 l	4300 Kg	18730 Kg
F-80x2	3875					16000 l	5400 Kg	21940 Kg
F-90x2	4175					18000 l	5800 Kg	25600 Kg
F-100x2	4475	1295	2074	2340		20000 l	6400 Kg	28400 Kg

All rights reserved. No part of this drawing may be reproduced or transmitted in any form or by any means, without the prior consent in writing of F.A.S.  
 Il presente disegno è di proprietà F.A.S. E' VIETATO riprodurlo e falsificarlo.

## Mod. Flx2

Vertical double bladder tank with foam inside the bladder, 2014/68 UE PED certificate

### Standard characteristics

**Body Material:** Carbon Steel

**Manhole:** Ø18"

**Membrane material:** Neoprene hypalon

**Design pressure:** 12 barg

**Test Pressure:** 18 barg

**Maximum working pressure:** 12 barg

**External finish:** Epoxy Primer + Polyuretanic red coat  
RAL3000, Total DFT >120 µm

**Capacity:** From 600 l (300x2) to 20000 l (10000x2)

**Foaming charge control:** With visual level indicator

**Tie rods and nuts in Stainless Steel**

**Mixer:** See dedicated page

**Suitable for seismic zone level 2b UBC - PGA 0,25 g**

### Approvals



### Optional

- > Manual pump
- > Ladder for manhole access
- > Vents control kit at mixer's height
- > Foaming charge control with visual level indicator
- > Base frame

### Notes

In case of inquiry and/or order specify the following datas:

- > Tank capacity, flow rate range, mixing percentage, flow direction, mixer's flange

### Available on Demand

- > Body Material: Other Material
- > Different Design Pressure
- > Capacity: 11000 liters or 12000 liters
- > Insulated tank
- > Coating: Other Painting Cycles
- > ASME Stamped
- > Designed for other seismic zone

For additional options or special versions contact FAS SpA

[www.fasspa.net](http://www.fasspa.net)

## Mod. Flx2

Vertical double bladder tank with foam inside the bladder, 2014/68 UE PED certificate

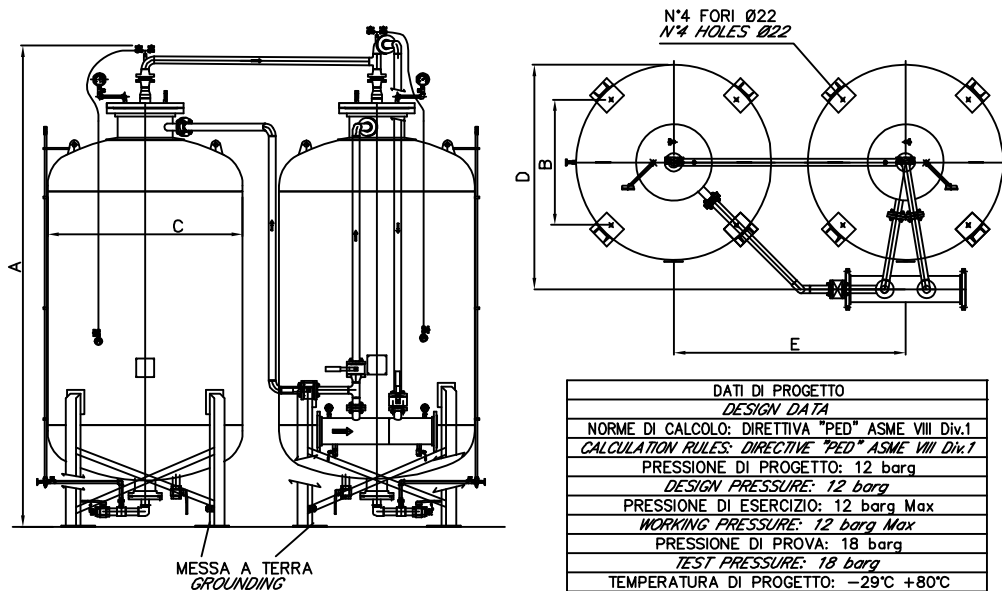

DATI DI PROGETTO	
DESIGN DATA	
NORME DI CALCOLO: DIRETTIVA "PED" ASME VIII Div.1	
CALCULATION RULES: DIRECTIVE "PED" ASME VIII Div.1	
PRESSIONE DI PROGETTO: 12 barg	
DESIGN PRESSURE: 12 barg	
PRESSIONE DI ESERCIZIO: 12 barg Max	
WORKING PRESSURE: 12 barg Max	
PRESSIONE DI PROVA: 18 barg	
TEST PRESSURE: 18 barg	
TEMPERATURA DI PROGETTO: -29°C +80°C	
DESIGN TEMPERATURE: -29°C +80°C	
EFFICIENZA GIUNTI: FONDI=1 FASCIAME=0.85	
JOINT EFFICIENCY : HEADS=1 - SHELL=0.85	
SOVRASPESORE DI CORROSIONE: NO	
CORROSION ALLOWANCE: NO	
RAGGI X: 10%	
X RAYS: 10%	
CLASSIFICAZIONE SISMICA:	
SEISMIC CLASSIFICATION:	
ZONA 2 (ITALIA) - ZONA 2b (UBC)	
ZONE 2 (ITALY) - ZONE 2b (UBC)	
ACCELERAZIONE AL SUOLO: 0,225 g (MAX)	
GROUND ACCELERATION: 0,225 g (MAX)	

MODELLO MODEL	A(mm)	B(mm)	ØC(mm)	D(mm)	E(mm)	CAPACITA' CAPACITY	PESO A VUOTO EMPTY WEIGHT	PESO IN ESERCIZIO WORKING WEIGHT
Fl-6x2	2135	535	922	1160	1380	1200 l	1280 Kg	2600 Kg
Fl-10x2	2735					2000 l	1600 Kg	3800 Kg
Fl-15x2	2835					3000 l	1880 Kg	5180 Kg
Fl-20x2	2745	850	1366	1585	1680	4000 l	2000 Kg	6400 Kg
Fl-25x2	3095					5000 l	2300 Kg	7800 Kg
Fl-30x2	3395					6000 l	2420 Kg	8920 Kg
Fl-40x2	3355	1045	1630	1875	1935	8000 l	3200 Kg	11520 Kg
Fl-50x2	3795					10000 l	3700 Kg	14070 Kg
Fl-60x2	3855	1190	1920	2210	2250	12000 l	3920 Kg	17120 Kg
Fl-70x2	3895					14000 l	4300 Kg	18730 Kg
Fl-80x2	3875					16000 l	5400 Kg	21940 Kg
Fl-90x2	4175	1295	2074	2340	2250	18000 l	5800 Kg	25600 Kg
Fl-100x2	4475					20000 l	6400 Kg	28400 Kg

All rights reserved. No part of this drawing may be reproduced or transmitted in any form or by any means, without the prior consent in writing of F.A.S.

Il presente disegno è di proprietà F.A.S. E' VIETATO riprodurlo e falsificarlo.



## Mod. H

Horizontal bladder tank with foam outside the bladder, 2014/68 UE PED certificate

### Standard characteristics

**Body Material:** Carbon Steel

**Manhole:** Ø18"

**Membrane material:** Neoprene hypalon

**Design pressure:** 12 barg

**Test Pressure:** 18 barg

**Maximum working pressure:** 12 barg

**External finish:** Epoxy Primer + Polyuretanic red coat  
RAL3000, Total DFT >120 µm

**Capacity:** From 1000 to 10000 liters

**Foaming charge control:** With valves on different levels

**Tie rods and nuts in Stainless Steel**

**Mixer:** See dedicated page

**Suitable for seismic zone level 2b UBC - PGA 0,25 g**

### Approvals

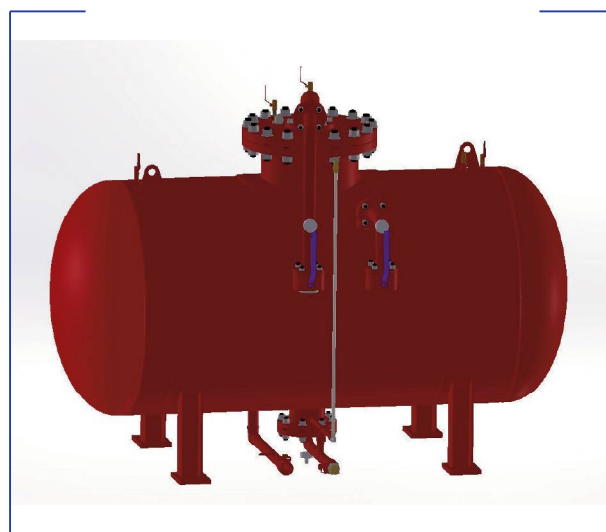

### Optional

- > Manual pump
- > Ladder for manhole access
- > Vents control kit at mixer's height
- > Foaming charge control with visual level indicator
- > Base frame

### Notes

In case of inquiry and/or order specify the following datas:

- > Tank capacity, flow rate range, mixing percentage, flow direction, mixer's flange

### Available on Demand

- > Body Material: Other Material
- > Different Design Pressure
- > Capacity: 11000 liters or 12000 liters
- > Insulated tank
- > Coating: Other Painting Cycles
- > ASME Stamped
- > Designed for other seismic zone

For additional options or special versions contact FAS SpA

[www.fasspa.net](http://www.fasspa.net)

## Mod. H

Horizontal bladder tank with foam outside the bladder, 2014/68 UE PED certificate

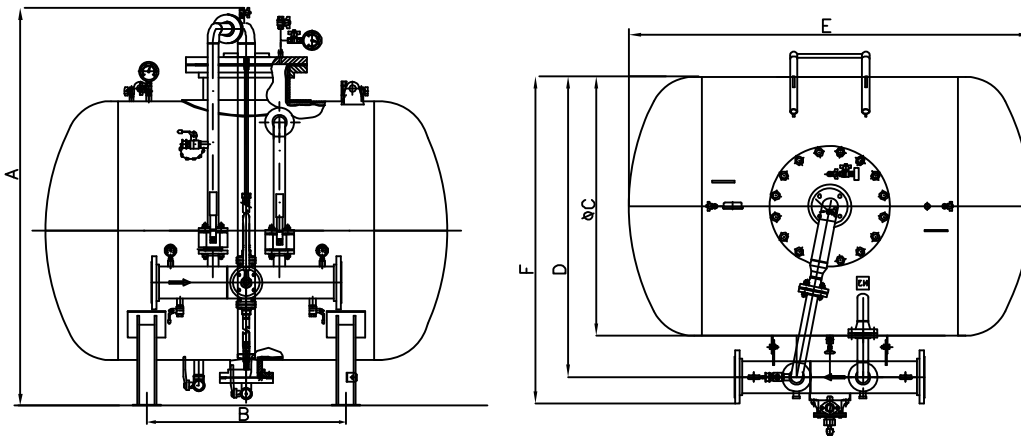

DATI DI PROGETTO	
DESIGN DATA	
NORME DI CALCOLO: DIRETTIVA "PED" ASME VIII Div.1	
CALCULATION RULES: DIRECTIVE "PED" ASME VIII Div.1	
PRESSIONE DI PROGETTO: 12 barg	
DESIGN PRESSURE: 12 barg	
PRESSIONE DI ESERCIZIO: 12 barg Max	
WORKING PRESSURE: 12 barg Max	
PRESSIONE DI PROVA: 18 barg	
TEST PRESSURE: 18 barg	
TEMPERATURA DI PROGETTO: -29°C +80°C	
DESIGN TEMPERATURE: -29°C +80°C	
EFFICIENZA GIUNTI: FONDI=1 FASCIAME=0.85	
JOINT EFFICIENCY : HEADS=1 - SHELL=0.85	
SOVRASPESORE DI CORROSIONE: NO	
CORROSION ALLOWANCE: NO	
RAGGI X: 10%	
X RAYS: 10%	
CLASSIFICAZIONE SISMICA:	
SEISMIC CLASSIFICATION:	
ZONA 2 (ITALIA) - ZONA 2b (UBC)	
ZONE 2 (ITALY) - ZONE 2b (UBC)	
ACCELERAZIONE AL SUOLO: 0,225 g (MAX)	
GROUND ACCELERATION: 0,225 g (MAX)	

MODELLO	A(mm)	B(mm)	ØC(mm)	D(mm)	E(mm)	F(mm)	CAPACITA'	PESO A VUOTO	PESO A PIENO
MODEL							CAPACITY	EMPTY WEIGHT	FULL WEIGHT
H-10	1650	900	922	1160	1770	1300	1000 l	800 Kg	1900 Kg
H-15	1840	950	1112	1360	1870	1500	1500 l	940 Kg	2590 Kg
H-20	1840	1300	1112		2420		2000 l	1000 Kg	3200 Kg
H-25	2100	1000	1366	1585	2130	1730	2500 l	1150 Kg	3900 Kg
H-30	2100	1300	1366		2430		3000 l	1450 Kg	4750 Kg
H-40	2360	1080	1630	1875	2380	2050	4000 l	1600 Kg	5760 Kg
H-50	2360	1550	1630		2880		5000 l	2060 Kg	7035 Kg
H-60	2650	1130	1920	2210	2570	2400	6000 l	2210 Kg	8560 Kg
H-70	2650	1450	1920		2920		7000 l	2360 Kg	9950 Kg
H-80	2805	1300	2074	2340	2900	2550	8000 l	2700 Kg	10970 Kg
H-90	2805	1600	2074		3200		9000 l	3060 Kg	12800 Kg
H-100	2805	1800	2074		3500		10000 l	3160 Kg	14200 Kg

All rights reserved. No part of this drawing may be reproduced or transmitted in any form or by any means, without the prior consent in writing of F.A.

Il presente disegno è di proprietà F.A.S. E' VIETATO riprodurlo e falsificarlo.

## Mod. HI

Horizontal bladder tank with foam inside the bladder, 2014/68 UE PED certificate

### Standard characteristics

**Body Material:** Carbon Steel

**Manhole:** Ø18"

**Membrane material:** Neoprene hypalon

**Design pressure:** 12 barg

**Test Pressure:** 18 barg

**Maximum working pressure:** 12 barg

**External finish:** Epoxy Primer + Polyuretanic red coat  
RAL3000, Total DFT >120 µm

**Capacity:** From 1000 to 10000 liters

**Foaming charge control:** With visual level indicator

**Tie rods and nuts in Stainless Steel**

**Mixer:** See dedicated page

**Suitable for seismic zone level 2b UBC - PGA 0,25 g**

### Approvals

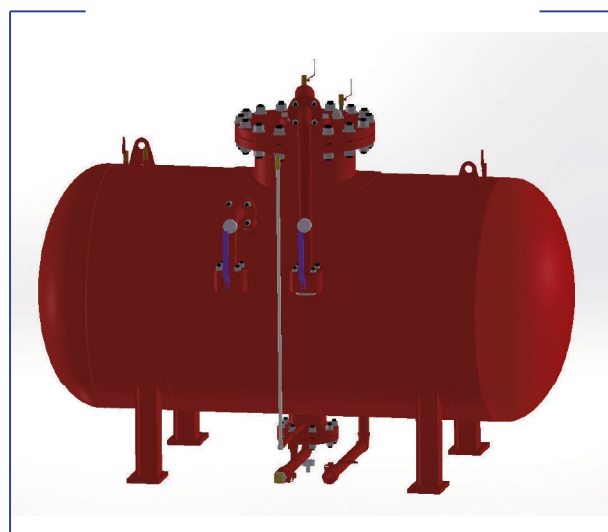

### Optional

- > Manual pump
- > Ladder for manhole access
- > Vents control kit at mixer's height
- > Foaming charge control with visual level indicator
- > Base frame

### Notes

In case of inquiry and/or order specify the following datas:

- > Tank capacity, flow rate range, mixing percentage, flow direction, mixer's flange

### Available on Demand

- > Body Material: Other Material
- > Different Design Pressure
- > Capacity: 11000 liters or 12000 liters
- > Insulated tank
- > Coating: Other Painting Cycles
- > ASME Stamped
- > Designed for other seismic zone

For additional options or special versions contact FAS SpA

[www.fasspa.net](http://www.fasspa.net)

## Mod. HI

Horizontal bladder tank with foam inside the bladder, 2014/68 UE PED certificate

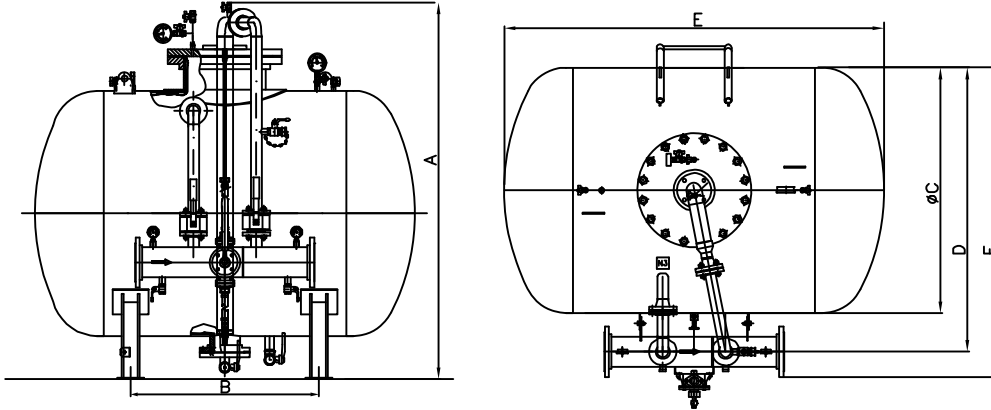

DATI DI PROGETTO	
DESIGN DATA	
NORME DI CALCOLO: DIRETTIVA "PED" ASME VIII Div.1	
CALCULATION RULES: DIRECTIVE "PED" ASME VIII Div.1	
PRESSIONE DI PROGETTO: 12 barg	
DESIGN PRESSURE: 12 barg	
PRESSIONE DI ESERCIZIO: 12 barg Max	
WORKING PRESSURE: 12 barg Max	
PRESSIONE DI PROVA: 18 barg	
TEST PRESSURE: 18 barg	
TEMPERATURA DI PROGETTO: -29°C +80°C	
DESIGN TEMPERATURE: -29°C +80°C	
EFFICIENZA GIUNTI: FONDI=1 FASCIAME=0.85	
JOINT EFFICIENCY: HEADS=1 - SHELL=0.85	
SOVRASPESSORE DI CORROSIONE: NO	
CORROSION ALLOWANCE: NO	
RAGGI X: 10%	
X RAYS: 10%	
CLASSIFICAZIONE SISMICA:	
SEISMIC CLASSIFICATION:	
ZONA 2 (ITALIA) - ZONA 2b (UBC)	
ZONE 2 (ITALY) - ZONE 2b (UBC)	
ACCELERAZIONE AL SUOLO: 0,225 g (MAX)	
GROUND ACCELERATION: 0,225 g (MAX)	

MODELLO MODEL	A(mm)	B(mm)	ØC(mm)	D(mm)	E(mm)	F(mm)	CAPACITA' CAPACITY	PESO A VUOTO EMPTY WEIGHT	PESO A PIENO FULL WEIGHT
HI-10	1650	900	922	1160	1770	1300	1000 l	800 Kg	1900 Kg
HI-15	1840	950	1112	1360	1870	1500	1500 l	940 Kg	2590 Kg
HI-20	1840	1300	1112		2420		2000 l	1000 Kg	3200 Kg
HI-25	2100	1000	1366	1585	2130	1730	2500 l	1150 Kg	3900 Kg
HI-30	2100	1300	1366		2430		3000 l	1450 Kg	4750 Kg
HI-40	2360	1080	1630	1875	2380	2050	4000 l	1600 Kg	5760 Kg
HI-50	2360	1550	1630		2880		5000 l	2060 Kg	7035 Kg
HI-60	2650	1130	1920	2210	2570	2400	6000 l	2210 Kg	8560 Kg
HI-70	2650	1450	1920		2920		7000 l	2360 Kg	9950 Kg
HI-80	2805	1300	2074	2340	2900	2550	8000 l	2700 Kg	10970 Kg
HI-90	2805	1600	2074		3200		9000 l	3060 Kg	12800 Kg
HI-100	2805	1800	2074		3500		10000 l	3160 Kg	14200 Kg

All rights reserved. No part of this drawing may be reproduced or transmitted in any form or by any means, without the prior consent in writing of F.A.S.

Il presente disegno è di proprietà F.A.S. E' VIETATO riprodurlo e falsificarlo.

## Mixer for bladder tanks

### Standard characteristics

**Body size:** From 3" to 8"

**Body Material:** Carbon Steel

**Inlet and outlet flanges:** ANSI 150# RF according to the size

**Design pressure:** 12 barg

**Coating:** Epoxy Primer + Polyuretanic red coat RAL3000,  
Total DFT >120 µm

**Calibrated water nozzle between flanges:** In stainless steel

**Foaming nozzle:** In stainless steel

**Upstream and downstream pressure gauges:** Scala 0÷25 barg

**STD working range:** 1÷10

### Approvals

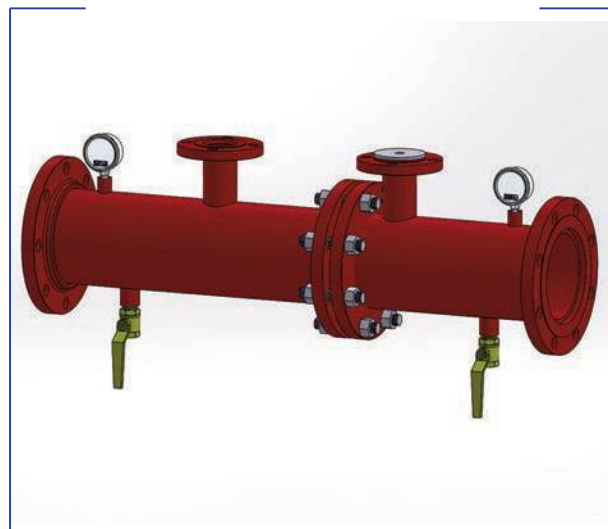

### Notes

In case of inquiry and/or order specify the following datas:

> Flanges type, body diameter, body material

### Available on Demand

- > Body Material: Other Material
- > Inlet and outlet flanges: Other type
- > Other Design Pressure
- > Other Body Size
- > Coating: Other Painting Cycles

[www.fasspa.net](http://www.fasspa.net)

# Mixer for bladder tanks

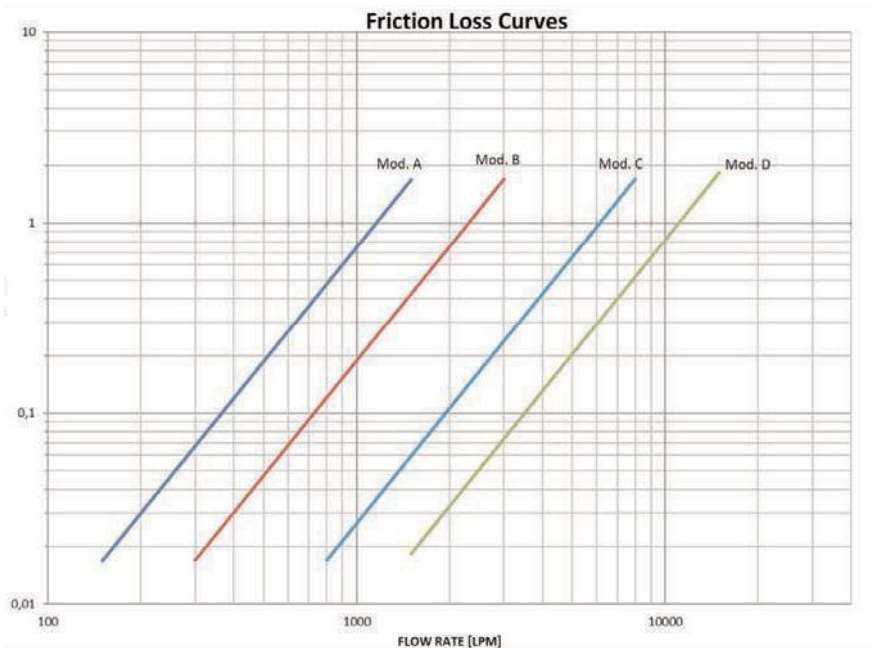
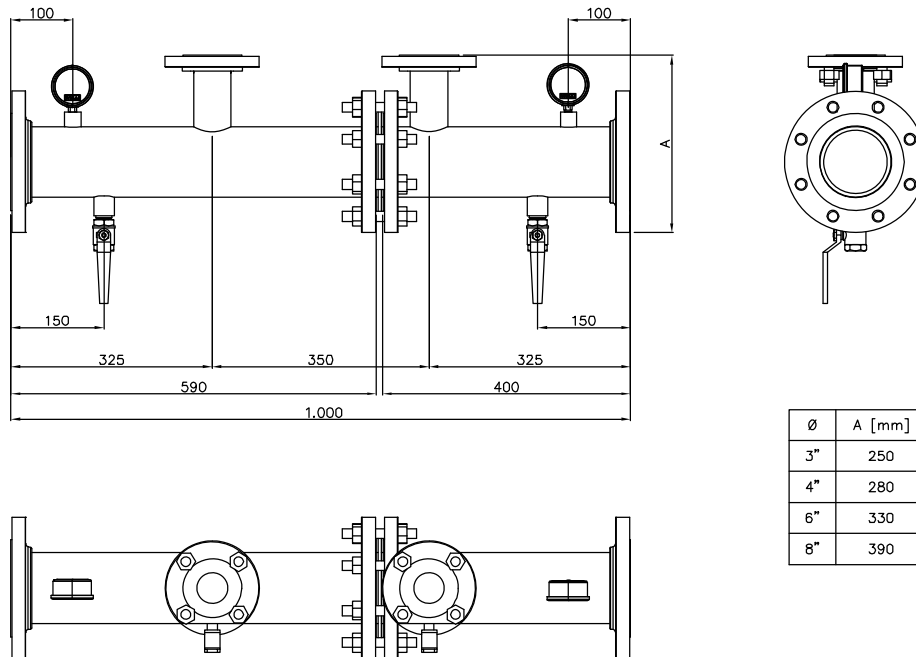

The Friction Loss Curves are based on Hydraulic Calculations according to NFPA Standard  
 Contact FAS Team for specific pressure loss depending by Hydraulic Calculation of your system

MIXER	FLOW RATE RANGE [LPM]	Ø WATER NOZZLE [MM]
MOD. A	150 ÷ 1500	STD
MOD. B	300 ÷ 3000	STD
MOD. C	800 ÷ 8000	STD
MOD. D	1500 ÷ 15000	STD

[www.fasspa.net](http://www.fasspa.net)