

Electro-Pneumatically Controlled Deluge Valve with Local Reset

Model FP 400Y - 6M

The BERMAD model 400Y-6M is an elastomeric, hydraulic, line pressure operated deluge valve, designed specifically for advanced fire protection systems and the latest industry standards.

The 400Y-6M is activated by a 3-way solenoid valve which in turn activates a pneumatic relay valve that latches the main valve open until locally reset.

The optional valve position indicator can include a limit switch suitable for Fire & Gas monitoring systems.

The 400Y-6M is ideal in systems with open nozzles for water or foam discharge, and is available with electric components to suit any hazardous location.



(for Illustration Only)

Benefits and Features

- **Safety and reliability**
 - Time proven, Simple, fail-safe actuation
 - Single piece, rugged elastomeric diaphragm seal - VRSD technology
 - Obstacle-free, uninterrupted flow path
 - No mechanical moving parts
 - Latches open: remains open until reset locally
- **High performance**
 - Very high flow efficiency
 - Straight through flow Y- type body
 - Approved for PN25 / 365 psi
- **Specifically designed for fire protection**
 - Face-to-face length standardized to ISO 5752 / EN 558-1
 - Meets the requirements of the industry standards
- **Quick and easy maintenance**
 - In-line serviceable
 - Fast and easy cover removal
 - Swivel mounted drain valves*

* not including 1½" & 2" valves

Typical Applications

- Automatic water spray systems
- Foam applications
- Corrosive water supplies
- Dual redundant detection systems

Approvals



UL-Listed
Special System Water Control
Valves, Deluge Type (VLFT)
Sizes 1½" - 16"



FM Approved
for Deluge Sprinkler Systems
Sizes 1½" - 8"



Det Norske Veritas
Type Approval



ABS
American Bureau of Shipping
Type Approval



Lloyd's Register
Type Approval

Additional Features

- Valve position limit switches
- Local valve position indicator beacon
- Alarm pressure switch
- Air maintenance device
- Sea water compatibility
- Drain valve/s inlet/outlet

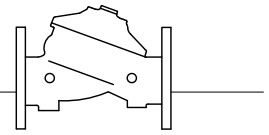

Operation

(for Illustration Only)

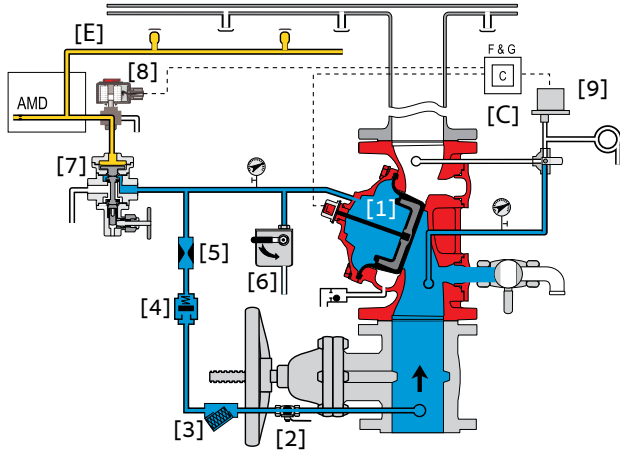

Valve Closed (set position)

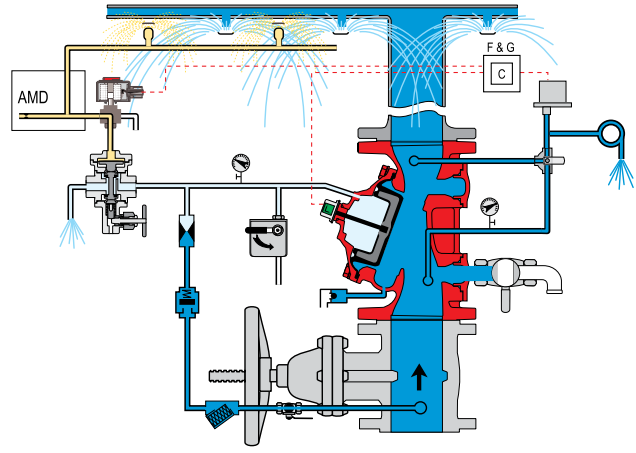

Valve Open (operating condition)

The BERMAD model 400Y-6M is held closed by water pressure in the control chamber [1]. Upon release of pressure from the control chamber, the valve opens.

Under NORMAL conditions, water pressure is supplied to the control chamber by the priming line [2] via the strainer [3], and restriction orifice [5], it is then trapped in the control chamber by a check valve [4], manual emergency release [6], and a relay valve (URV-M) [7]. The relay valve is held closed by pneumatic pressure supplied through a three-way solenoid valve [8]. The water pressure trapped in the main valve control chamber holds the diaphragm against the valve seat, sealing it drip-tight and keeping the system pipes dry.

Under FIRE conditions, water pressure is released from the control chamber. The URV-M opens in response either to a decrease in pneumatic pilot-line pressure [E] or to the solenoid valve being activated by the fire & gas control system [C]. This latches the 400Y-6M deluge valve open, allowing water to flow into the system piping and to the alarm device [9].

System P&ID

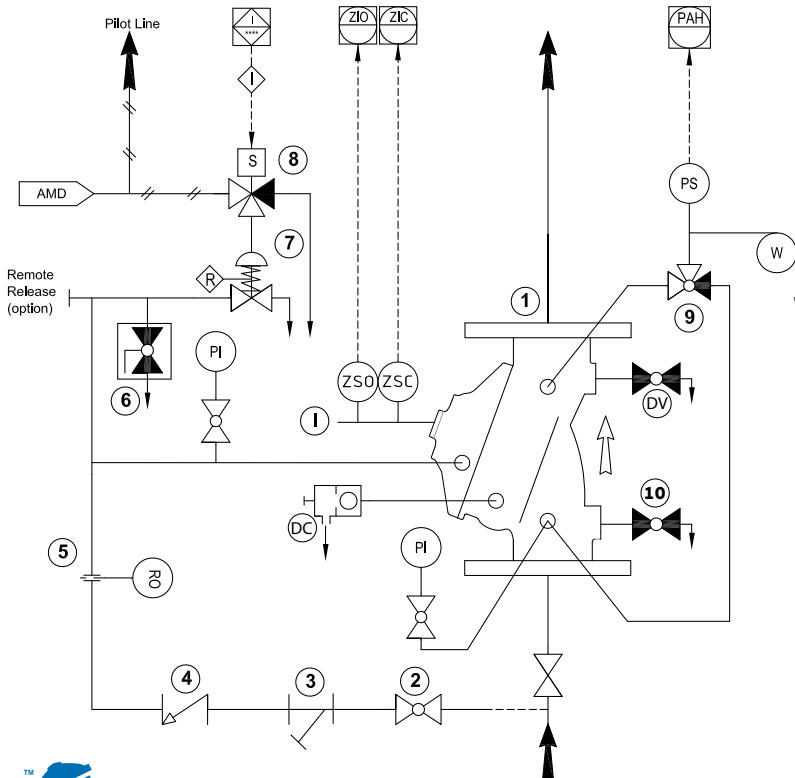

Components

- 1 BERMAD 400Y Deluge Valve
- 2 Priming Ball Valve
- 3 Priming Strainer
- 4 Check Valve
- 5 Restriction Orifice
- 6 Manual Emergency Release
- 7 URV-2-M Relay Valve
- 8 3-Way Solenoid Valve

Optional System Items

- ZS Limit Switch Assembly
- I Valve Position Indicator
- DV Additional Drain Valve
- PS Pressure Switch
- AMD Air Maintenance Device
- W Water Motor Alarm
- PI Pressure Gauge*
- DC Automatic Drip Check Valve*
- 9 3-Way Alarm Ball Valve*
- 10 Main Drain Valve*

See also Factory Fitted Options under the Valve Code Designations on the last page

*Mandatory for FM approval
(suffix A in code designations on page 4)



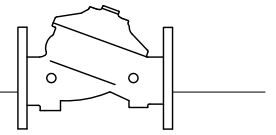

System Installation

A typical installation of the BERMAD model 400Y-6M features automatic actuation via a relay valve, triggered by a fusible plug loop. It can also be triggered electrically by a signal from a fire & gas control system or an on-site emergency pushbutton. When open and fitted with a limit switch the valve can send a feedback signal to a remote valve status monitoring system.

Optional System Items

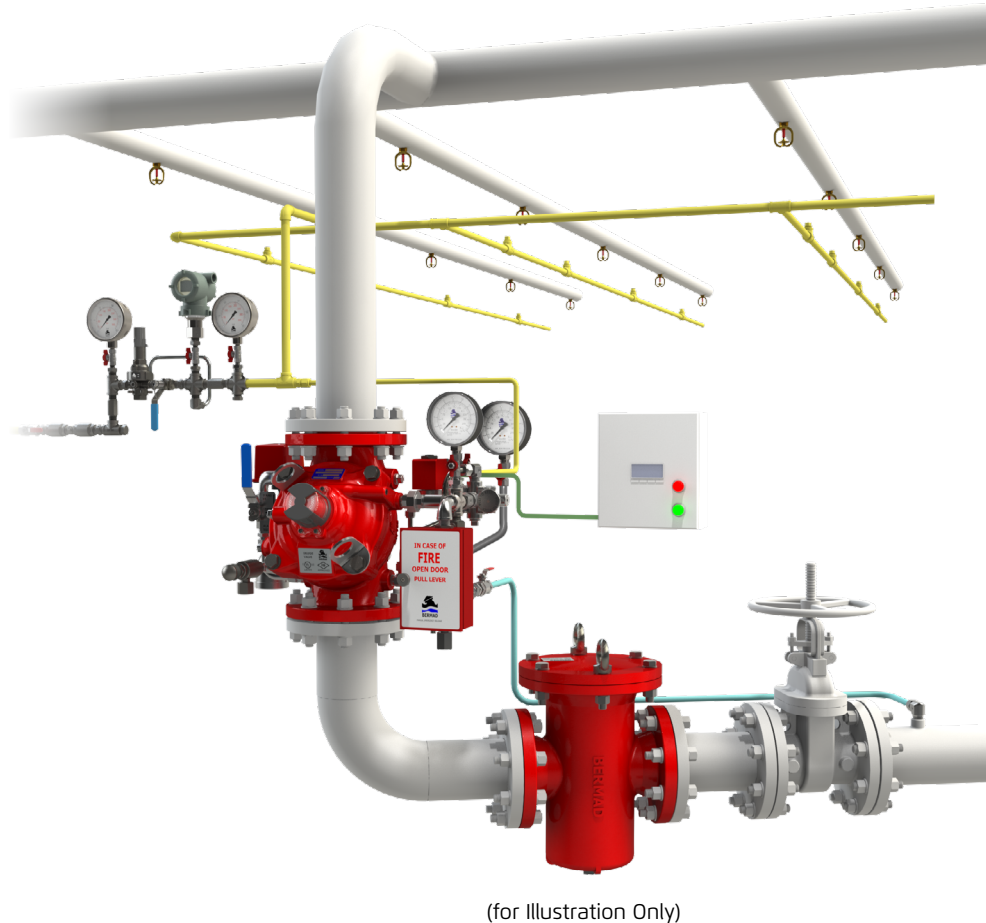
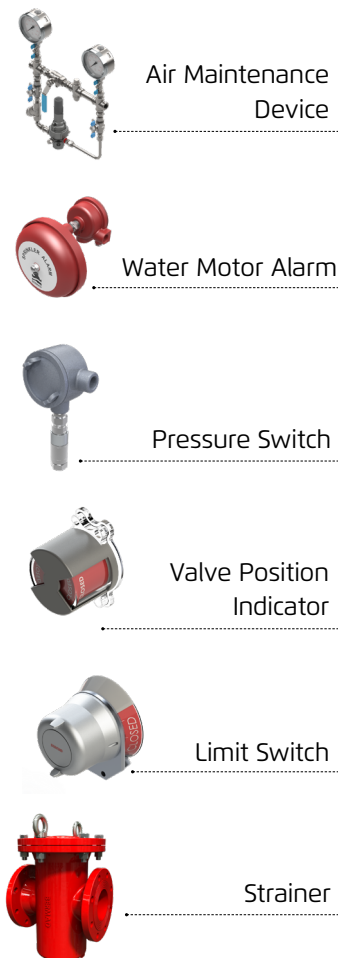

(for Illustration Only)

Suggested Specifications:

The deluge valve shall be UL-listed and FM-approved, 25-bar/365-psi rated, with a straight-through, Y-type-body.

The valve shall have an unobstructed flow path, with no stem guide or supporting ribs.

Valve actuation shall be accomplished by a single-piece rolling diaphragm, bonded with a rugged radial seal disk. The diaphragm assembly shall be the only moving part.

The deluge valve shall include a latching relay pilot valve, a 3-Way solenoid valve FM approved for 25 bar/365 psi working pressure, with a tolerance of 35% below the rated voltage, a Y-type strainer, a ball drain valve, an automatic drip-check with manual override, 4-inch pressure gauges, and a manual emergency release housed in a stainless steel box.

The valve shall be equipped with a dual-color, rotational position indicator, readable from 50 meters enclosed in a protective switch box. Removing the valve cover for inspection or maintenance shall be in-line and not require removal of the trim.

The deluge valve and its entire control trim shall be supplied pre-assembled and hydraulically tested by a factory certified to ISO 9000 and 9001.

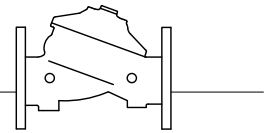

Technical Data

Available Sizes (inch)

- Flanged - 1½, 2, 3, 4, 6, 8, 10, 12, 14 & 16"
- Grooved - 1½, 2, 3, 4, 6 & 8"
- Threaded - 1½ & 2"

Pressure Rating

- ANSI#150 - 16 bar / 235 psi
- ANSI#300 - 1½" to 10" 25 bar / 365 psi
12" to 16" 20 bar / 300 psi
- Grooved/Threaded - 25 bar / 365 psi - 25 bar / 365 psi

Elastomer

- HTNR - Fabric Reinforced High Temperature Compound - See engineering data

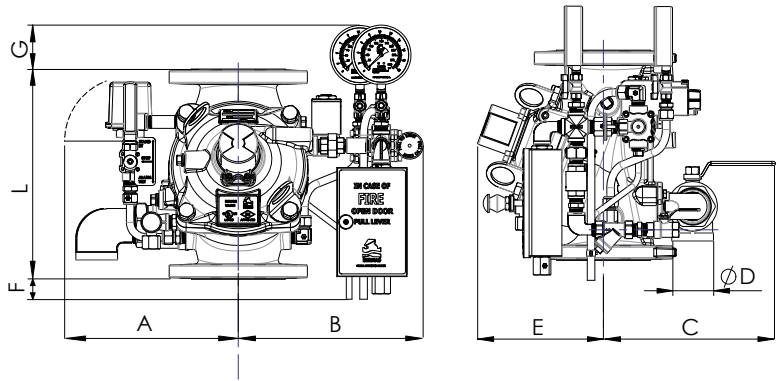

Valve Size	1½" DN40	2" DN50	3" DN80	4" DN100	6" DN150	8" DN200	10" DN250	12" DN300	14" DN350	16" DN400
⁽¹⁾ L ANSI #150 mm (in.)	230(9.06)	230(9.06)	310(12.21)	350(13.79)	480(18.91)	600(23.64)	730(28.76)	850(33.49)	980(38.61)	1100(43.34)
L ² ANSI #300 mm (in.)	230(9.06)	238(9.37)	326(12.84)	368(14.50)	506(19.94)	626(24.66)	730(28.76)	888(34.96)	980(38.61)	1100(43.34)
A mm (in.)	330(13.0)	330(13.0)	390(15.4)	398(15.7)	451(17.8)	481(18.9)	481(18.9)	594(23.4)	594(23.4)	594(23.4)
B mm (in.)	300(11.8)	300(11.8)	358(14.1)	368(14.5)	423(16.7)	451(17.8)	451(17.8)	564(22.2)	564(22.2)	564(22.2)
C mm (in.)	241(9.5)	241(9.5)	274(10.8)	290(11.4)	304(12.0)	320(12.6)	320(12.6)	383(15.1)	383(15.1)	408(16.1)
ØD	¾"	¾"	1½"	2"	2"	2"	2"	2"	2"	2"
E mm (in.)	167(6.6)	167(6.6)	191(7.5)	205(8.1)	273(10.7)	338(13.3)	338(13.3)	490(19.3)	490(19.3)	465(18.3)
F mm (in.)	177(7.0)	177(7.0)	107(4.2)	80(3.2)	-	-	-	-	-	-
G mm (in.)	121(4.8)	121(4.8)	111(4.4)	98	50	25	-	-	-	-
Kv m ³ /h (Cv gpm)	68(79)	80(92)	190(219)	345(398)	790(912)	1160(1340)	1355(1565)	2370(2737)	2850(3292)	3254(3758)
⁽²⁾ Leq m (ft)	2(7)	5(16)	7(23)	9(30)	15(49)	27(89)	62(203)	52(171)	59(194)	88(289)
Weight, flanged kg (lbs)	15.26(33.5)	16.66(36.6)	31.36(69.0)	41.36(91.0)	84.66(186.3)	147.86(325.3)	177.86(391.3)	320.86(705.9)	353.86(778.5)	399.86(879.7)

Notes: ⁽¹⁾ L1 Dimensions are for grooved, threaded and raised face flanged valves

⁽²⁾ Leq (Equivalent Pipe Length) refers to turbulent flow in new steel pipe schedule 40, values given for general consideration only

⁽³⁾ Dimensions for the trim envelope may vary with specific component positioning

Valve Code Designations

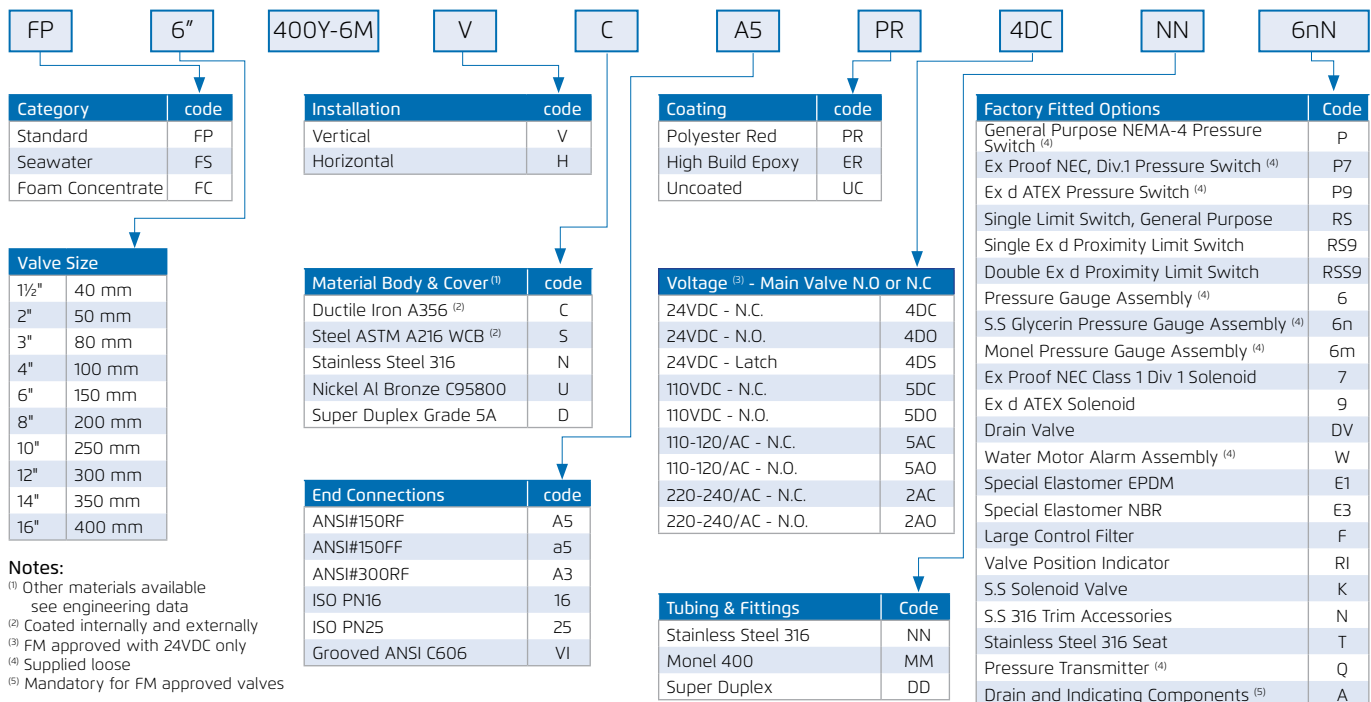

Notes:

- ⁽¹⁾ Other materials available see engineering data
- ⁽²⁾ Coated internally and externally
- ⁽³⁾ FM approved with 24VDC only
- ⁽⁴⁾ Supplied loose
- ⁽⁵⁾ Mandatory for FM approved valves

