

Adjustable Direct Acting Low Flow Pressure Reducer

¾"- PRV-05

The BERMAD Adjustable Direct Acting Low Flow Pressure Reducer is actuated by a pressure responsive diaphragm, which seeks to reach equilibrium between hydraulic and set spring force. The BERMAD Model ¾"-PRV-05 is built of reinforced plastic that endows it with excellent hydraulic performance capabilities and high mechanical strength. Supplied with a special throttling plug and elastomeric seal, it reduces higher upstream pressure to lower constant downstream pressure even under conditions of near zero demand.



Features and Benefits

- Advanced Construction Materials
 - High mechanical strength
 - Proven pressure, flow and weather resistance
- Adjustable Direct Acting Pressure Reducer
 - Constant downstream pressure
 - Immediate response
 - Settable according to season and stage
- Plastic Body and Trim
 - Highly durable, chemical and cavitation resistant
 - Minimizes friction
- Unitized Rolling Diaphragm and Guided Plug
 - Accurate and stable regulation
 - Prevents diaphragm distortion
- User-Friendly Design
 - Can be installed at any orientation
 - Simple in-line inspection and service

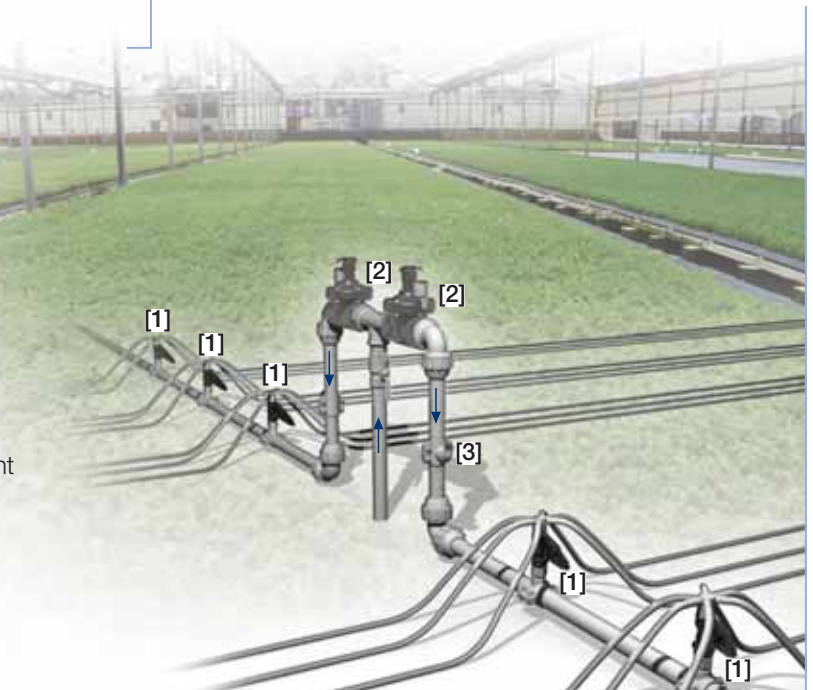

Typical Applications

- Distribution Line Lateral Risers
- Non-Compensating Drip-Line Flow Fixation
- Lateral Final Burst Protection
- Pressure Reduction for Marginal Plots

[1] BERMAD Model ¾"-PRV-05 protects laterals and compensates for line friction, ensuring dripper flow per design.

[2] BERMAD Solenoid Controlled Valve Model IR-210-N-M

[3] BERMAD Vacuum Breaker Model ½"-ARV

BERMAD Irrigation

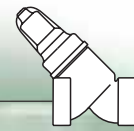

3/4" - PRV-05

For full technical details, refer to Engineering Section.

PRV Series

Pressure Reducing

Technical Specifications

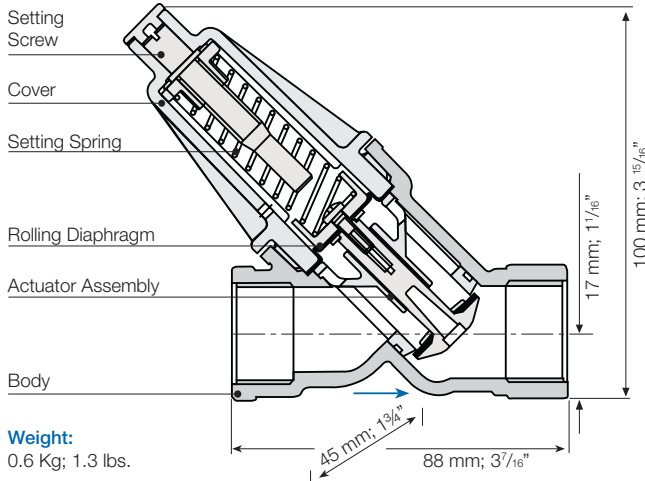

Flow Chart required supply pressure above setting

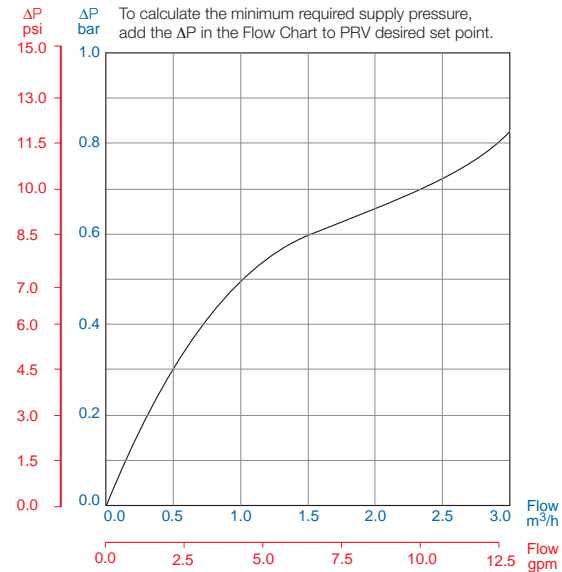

Technical Data

Size: 3/4"; DN20

End Connections: Threaded

Inlet: Female BSP; NPT

Outlet: Female BSP; NPT or Male BSPT; NPT

Flow Range: 0.01-3 m³/h; 0.04-13 gpm

Pressure Ratings: 9 bar; 130 psi

Operating Pressure Range: 0.7-9 bar; 10-130 psi

Temperature: Water up to 50°C; 122°F

Materials:

Body, Cover and Actuator Assembly: Glass-Filled Nylon

Diaphragm: NBR (Buna-N), Nylon fabric reinforced

Spring: Stainless Steel

Operation

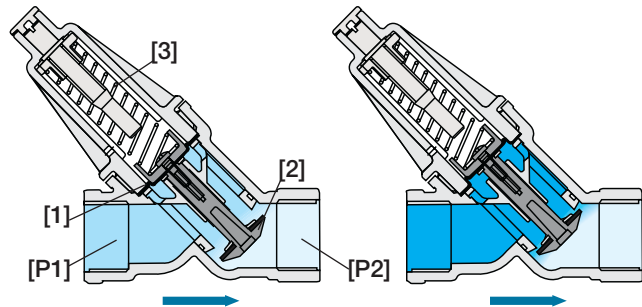

The Upstream Pressure [P1] applies balanced opening and closing hydraulic forces under the Diaphragm [1] and above the Plug [2]. The Downstream Pressure [P2] applies hydraulic closing force under the plug, which seeks to reach equilibrium with the Set Spring [3] force. Should [P2] rise above setting, the hydraulic closing forces rise above the mechanical force of the spring, pushing the plug to modulate closed, and reducing [P2] back to setting.

Setting Springs Selection Table

Setting Range bar, psi	Spring Color	Spring Name
0.5-1.2; 7-18	Yellow	A
0.8-2.5; 12-36	White	B
2.0-4.0; 29-58	Red	C
3.5-6.0; 50-87	Black	D

How to Order

For Ordering Please Specify:

- Adjustable Direct Acting Pressure Reducer 3/4", Female BSP Threads BERMAD Model: 3/4"-PRV-P-BP-FF-___*
- Adjustable Direct Acting Pressure Reducer 3/4", Female NPT Threads BERMAD Model: 3/4"-PRV-P-NP-FF-___*
- Adjustable Direct Acting Pressure Reducer 3/4", Male BSPT Outlet Thread BERMAD Model: 3/4"-PRV-P-BP-MF-___*
- Adjustable Direct Acting Pressure Reducer 3/4", Male NPT Outlet Thread BERMAD Model: 3/4"-PRV-P-NP-MF-___*

* Choose the desired spring and mark A, B, C or D according to "Setting Springs Selection Table"



info@bermad.com • www.bermad.com

The information herein is subject to change without notice. BERMAD shall not be held liable for any errors. All rights reserved. © Copyright by BERMAD. PCPAE07-05 05