



## Pressure Sustaining and Reducing Valve

### Model 723

- Protecting lower pressure zones
- Prioritizing higher pressure zones
- Preventing pipeline emptying
- Ensuring controlled pipeline fill-up
- Pump overload & cavitation protection
- Compensating during groundwater drawdown

The Model 723 Pressure Sustaining and Reducing Valve is a hydraulically operated, diaphragm actuated control valve with two independent functions. It sustains minimum pre-set upstream pressure regardless of fluctuating flow or varying downstream pressure, and it prevents downstream pressure from rising above maximum pre-set regardless of fluctuating flow or excessive upstream pressure.



### Features and Benefits

- **Line pressure driven** – Independent operation
- **In-line serviceable** – Easy maintenance
- **Double chamber design**
  - Moderated valve reaction
  - Protected diaphragm
- **Flexible design** – Easy addition of features
- **Variety of accessories** – Perfect mission matching
- **“Y” or angle, wide body** – Minimized pressure loss
- **Semi-straight flow** – Non-turbulent flow
- **Stainless Steel raised seat** – Cavitation damage resistant
- **Obstacle free, full bore** – Uncompromising reliability
- **V-Port Throttling Plug** – Low flow stability

### Major Additional Features

- Solenoid control – **723-55**
- Check feature – **723-20**
- High sensitivity pilots – **723-12**
- Solenoid control & check feature – **723-25**
- Downstream over pressure guard – **723-48**
- Proportional – **723-PD**

See relevant BERMAD publications.



## Operation

The Model 723 is a pilot controlled valve equipped with two adjustable, 2-Way pilots, pressure sustaining (PS) and pressure reducing (PR), operating independently in series.

The restriction [1] continuously allows flow from the valve inlet into the upper control chamber [2]. The PS pilot [3] and the PR pilot [4] together control outflow from the upper control chamber.

Should upstream pressure fall below PS pilot setting, the pilot closes causing pressure to accumulate in the upper control chamber. The main valve throttles closed sustaining upstream pressure at the pilot setting. Should upstream pressure rise above PS pilot setting, the pilot releases accumulated pressure from the upper control chamber to the main valve outlet through the held open PR pilot, opening the main valve. Should opening the main valve cause downstream pressure to rise above PR pilot setting, the pilot closes, causing the main valve to throttle closed reducing downstream pressure to PR pilot setting.

The V-Port plug (optional) [5] increases the ratio of flow to stem travel, providing more accurate, stable and smooth regulation. The integral orifice between the lower control chamber and valve outlet moderates valve reactions.

The one-way flow control needle valve [6] stabilizes the valve's reaction in hard regulation conditions, by restricting the flow out of the control chamber.

The downstream cock valve [7] enables manual closing.

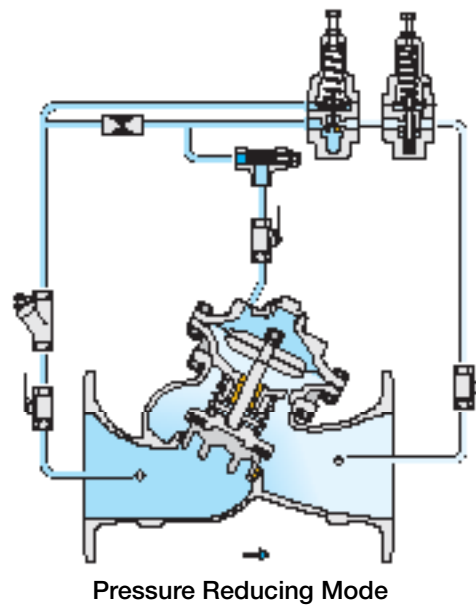
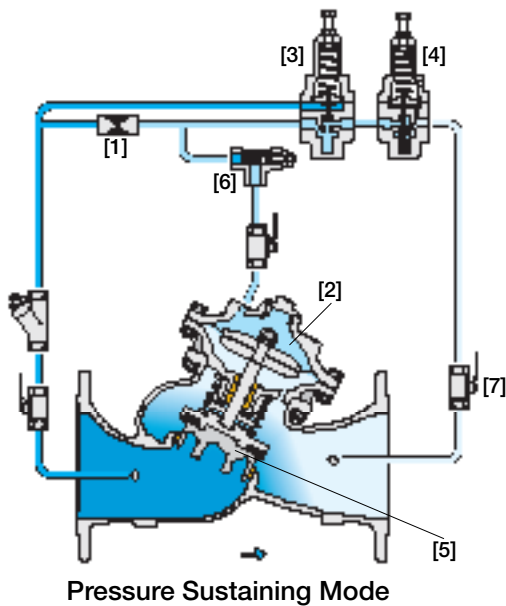

## Pilot System Specifications

### Standard Materials:

#### Pilots:

Body: Stainless Steel 316 or Bronze

Elastomers: Synthetic Rubber

Springs: Galvanized Steel or Stainless Steel

#### Tubing & Fittings:

Stainless Steel 316 or Copper & Brass

#### Accessories:

Stainless Steel 316, Brass and Synthetic

Rubber Elastomers

### Pilots Adjustment Range:

0.5 to 3.0 bar ; 7 to 40 psi

0.8 to 6.5 bar ; 11 to 95 psi

1 to 16 bar ; 15 to 230 psi

5 to 25 bar ; 70 to 360 psi

### Notes:

- Inlet pressure, outlet pressure and flow rate are required for optimal sizing and cavitation analysis
- Recommended continuous flow velocity:  
0.3-6.0 m/sec ; 1-20 ft/sec
- Minimum operating pressure: 0.7 bar ; 10 psi.  
For lower pressure requirements consult factory



## Typical Applications

Water is pumped from a deep well to the reservoir through a line also supplying nearby consumers along the way. Water is then supplied from the reservoir to both higher and lower elevation consumers. Both parts of the system require pressure sustaining and reducing solutions.

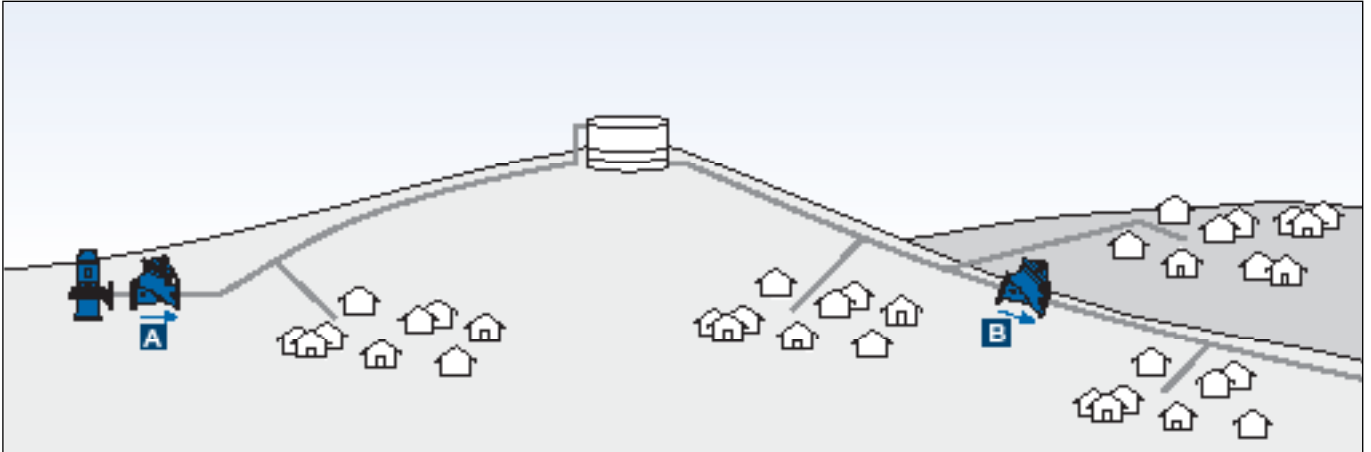

### Groundwater Draw Down System

In deep well pumping systems, the groundwater level varies according to: seasonal changes, seepage rate, and demand. These systems require a solution to a unique combination of issues:

- Consumer demand or filling an empty line results in pump overload and cavitation, requiring pressure sustaining.
- Deep well pumps boost a constant  $\Delta P$ , resulting in high ground level raising the discharge pressure, requiring pressure reducing.

The Model 723 provides a complete solution for both of these issues. Adding check feature "20", saves the cost of a line-sized check valve.

### Gravity Fed Supply Line

Where consumers at both higher and lower elevations use the same distribution network:

- Consumers located at higher elevation need protection against over demand by the lower zone.
- Lower zone consumers need protection against high gravity fed pressure.

The Model 723, being both a pressure sustaining and reducing valve, simultaneously fulfills both requirements.

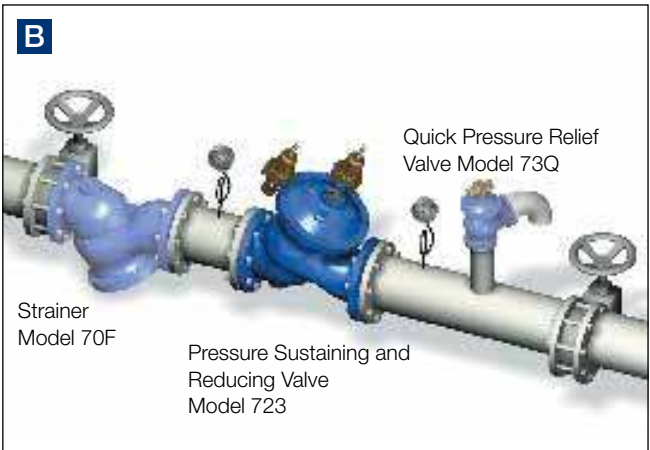
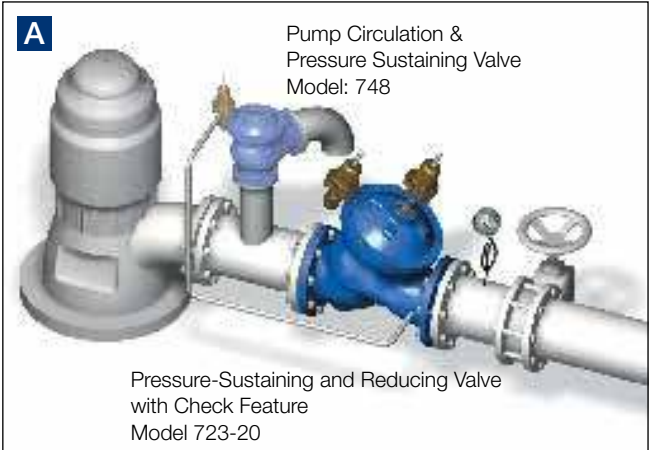



### Technical Data

**Size Range:** DN40-900 ; 1½-36"

**End Connections (Pressure Ratings):**

**Flanged:** ISO PN16, PN25 (ANSI Class 150, 300)

**Threaded:** BSP or NPT

**Others:** Available on request

**Valve Patterns:** "Y" (globe) & angle, globe (DN600-900 ; 24"-36")

**Working Temperature:** Water up to 80°C ; 180°F

**Standard Materials:**

**Body & Actuator:** Ductile Iron

**Internals:** Stainless Steel, Bronze & coated Steel

**Diaphragm:** Synthetic Rubber Nylon fabric-reinforced

**Seals:** Synthetic Rubber

**Coating:** Fusion Bonded Epoxy, RAL 5005 (Blue) approved for drinking water or Electrostatic Polyester Powder

### Differential Pressure Calculation

$$\Delta P = \left( \frac{Q}{Kv; Cv} \right)^2$$

**ΔP** = Differential Pressure for fully open valve (bar; psi)

**Q** = Flow rate (m³/h; gpm)

**Kv** = Metric system - valve flow coefficient  
(flow in m³/h at 1 bar ΔP with 15°C water)

**Cv** = US system - Valve flow coefficient  
(flow in gpm at 1 psi ΔP with 60°F water)

$$Cv = 1.155 Kv$$

### Flow Data & Dimensions Table

DN / Size		40	1.5"	50	2"	65	2.5"	80	3"	100	4"	150	6"	200	8"	250	10"	300	12"	350	14"	400	16"	450	18"	500	20"		
Flow Data	700 & 700ES	Kv / Cv - Flat																											
	700 & 700EN	Kv / Cv - "Y" Flat																											
	700 & 700EN	Kv / Cv - "Y" V-Port																											
700-ES	PN16; 25	L (mm / inch)																											
	PN16; 25	W (mm / inch)																											
	PN16; 25	h (mm / inch)																											
	PN16; 25	H (mm / inch)																											
	PN16; 25	Weight (Kg/lb)																											
700-EN	PN16; 25	L (mm / inch)																											
	PN16; 25	W (mm / inch)																											
	PN16; 25	h (mm / inch)																											
	PN16; 25	H (mm / inch)																											
	PN16; 25	Weight (Kg/lb)																											
700 Flanged	"Y" PN16 Class 150	L (mm / inch)																											
		W (mm / inch)																											
		h (mm / inch)																											
		H (mm / inch)																											
		Weight (Kg/lb)																											
	"Y" PN25 Class 300	L (mm / inch)																											
		W (mm / inch)																											
		h (mm / inch)																											
		H (mm / inch)																											
		Weight (Kg/lb)																											
700 Threaded	"Y" PN16; 25 Class 150; 300	L (mm / inch)																											
		W (mm / inch)																											
		h (mm / inch)																											
		H (mm / inch)																											
		Weight (Kg/lb)																											
	Angle PN16; 25 Class 150; 300	L (mm / inch)																											
		W (mm / inch)																											
		R (mm / inch)																											
		h (mm / inch)																											
		H (mm / inch)																											

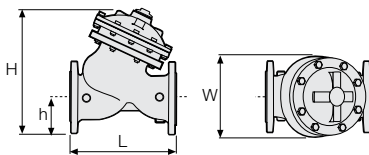

### Specify when ordering:

- Size
- Main model
- Additional features
- Pattern
- Body material
- End connection
- Coating
- Voltage & main valve position
- Tubing & Fittings materials
- Operational data (according to model)
- Pressure data
- Flow data
- Reservoir level data
- Settings

\* Use BERMAD's Waterworks Ordering Guide

DN / Size		600	24"	700	28"	750	30"	800	32"	900	36"
Globe PN16 Class 150	L (mm / inch)	1,450	57.1	1,650	65	1,750	68.9	1,850	72.8	1,850	72.8
	W (mm / inch)	1,250	49.2	1,250	49.2	1,250	49.2	1,250	49.2	1,250	49.2
	h (mm / inch)	470	18.5	490	19.3	520	20.5	553	21.8	600	23.6
	H (mm / inch)	1,965	77.4	1,985	78.1	2,015	79.3	2,048	80.6	2,095	82.5
	Weight (Kg/lb)	3,250	7,150	3,700	8,140	3,900	8,580	4,100	9,020	4,250	9,350
Globe PN25 Class 300	L (mm / inch)	1,500	59.1	1,650	65	1,750	68.9	1,850	72.8	1,850	72.8
	W (mm / inch)	1,250	49.2	1,250	49.2	1,250	49.2	1,250	49.2	1,250	49.2
	h (mm / inch)	470	18.5	490	19.3	520	20.5	553	21.8	600	23.6
	H (mm / inch)	1,965	77.4	1,985	78.1	2,015	79.3	2,048	80.6	2,095	82.5
	Weight (Kg/lb)	3,500	7,700	3,700	8,140	3,900	8,580	4,100	9,020	4,250	9,370

