

BERMAD Irrigation

200 Series - Plastic Hydraulic/Electric Control Valves

Water Control Solutions

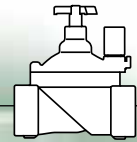



200 Series

Plastic Hydraulic/Electric Control Valves

for residential, commercial and agricultural irrigation systems.

The BERMAD 200 Series plastic control valves are globe pattern (¾"-2") or Angle pattern (1½"-2"). These control valves provide superior hydraulic performance, demonstrating state-of-the-art hydraulics and plastics technology.

Features and Benefits

- Spring Loaded Elastomeric Valve
 - Self operated
 - Range of closing springs
- Plastic Globe/Angle Hydro-Efficient Valve
 - Unobstructed flow path
 - Single moving part
 - High flow capacity
 - Highly durable, chemical and cavitation resistant
- Flexible Balanced Diaphragm and Seal
 - Fully opening
 - Secures drip-tight closing
- User-Friendly Design
 - Simple in-line inspection



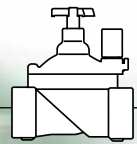

200 Series Valves

The BERMAD 200 Series is a line of plastic hydraulic/electric control valves for residential, commercial and agricultural irrigation systems.

This diaphragm actuated hydraulically operated plastic control valve combines simple and reliable construction with good hydraulic performance. These automatic water control valves are designed for vertical or horizontal installation and are available in Globe or Angle patterns in diameter sizes of ¾"-2".

The IR-200 valves are divided into two main types – Hydraulic Valve and Electric Valve. The Electric Valve control circuit is internal providing some significant benefits such as:

- No external tubes and accessories
- Compact and protected construction
- Self-cleaning orifice for reliable valve operation, even with brackish water.

The IR 200 Series Valves are durable plastic valves. The valve body, cover, and seal disk assembly construction material uses Glass-Filled Nylon to meet rough service conditions obtaining high chemical and cavitation resistance.

The valve body design includes a full bore seat with unobstructed flow path, free of any in-line ribs, supporting cage, or shafts. Its seal disk assembly includes a flexible, carefully balanced and peripherally supported diaphragm and a rugged guided plug with elastomeric sealing surface. This internal design enables:

- High flow rate with low head loss
- Smooth valve opening and closing
- Accurate and stable regulation
- Low opening and actuation pressure
- No diaphragm erosion and distortion
- Same diaphragm and spring fully meet the valve's operating pressure range requirements

The IR-200 Series Valves use valve differential pressure to power the diaphragm assembly to open or close. The lower side of the diaphragm, which serves to cushion the closing of the valve, is exposed to downstream pressure through a peripheral passageway. The pressure in the control chamber varies, resulting from the action of a solenoid or a regulating pilot. This varying pressure modulates the valve to open or close.



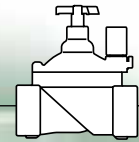

Manual On-Off Control

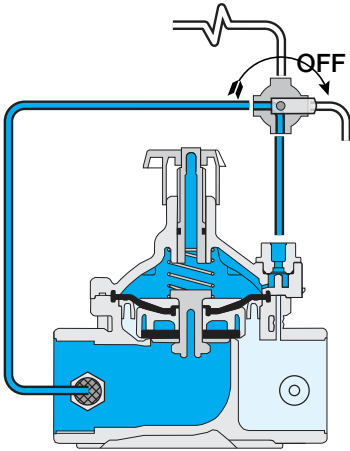

Closed Position

Line pressure applied to the control chamber of the valve creates a superior force that changes the valve position to close, providing drip tight sealing.

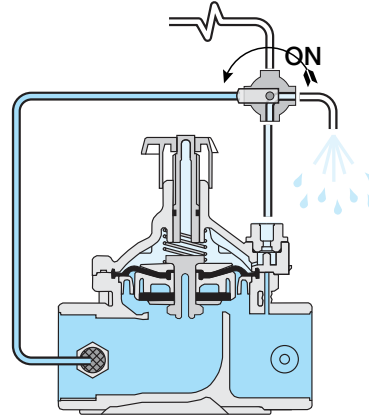

Open Position

Discharging the pressure in the control chamber to atmosphere or some other lower pressure zone causes the line pressure acting on the seal disc to change the valve position to open.

3-Way Modulating Modes, Pressure Reducing

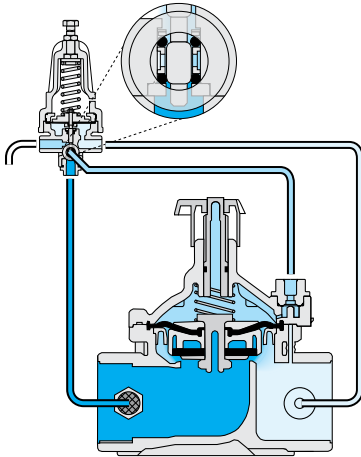

Locked Position

When sensed pressure is equal to setting, the pilot shaft moves and blocks both the drain port and the pressure port. This locks the pressure in the control chamber, freezing the valve in its last position until conditions change.

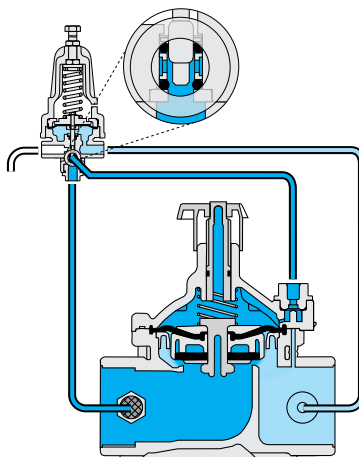

Modulating Closed

The pilot switches upon pressure rise, blocking the drain port and opening the pressure port. This pressurizes the control chamber, forcing the valve to modulate closed.

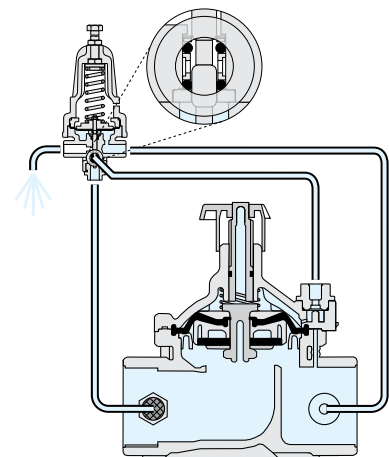

Fully Open Position

When upstream pressure drops, the pilot blocks the pressure port and opens the drain port, venting the control chamber to the atmosphere. This fully opens the valve, minimizing head loss.

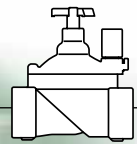

2-Way Solenoid Controlled, Normally Closed (N.C.)

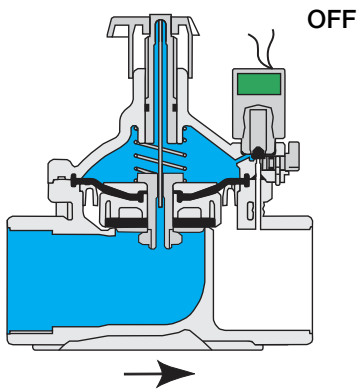

Closed Position

The internal restriction continuously allows line pressure into the control chamber. The solenoid controls outflow from the control chamber. When the solenoid is closed it causes pressure to accumulate in the control chamber, therefore forcing the valve to close.

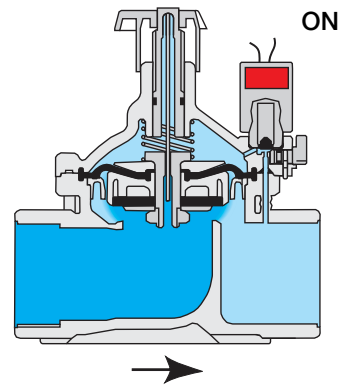

Open Position

Opening the Solenoid releases more flow from the control chamber than the restriction can allow in. This causes the accumulated pressure in the control chamber to drop, enabling the line pressure acting on the plug to the valve.

3-Way Solenoid Controlled, Normally Open (N.O.)

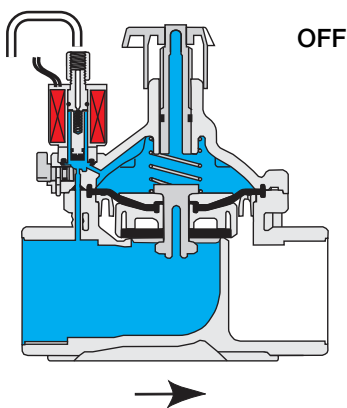

Closed Position

Energizing the solenoid opens the internal line pressure inlet and blocks the drain port. This pressurizes the control chamber, closing the valve.

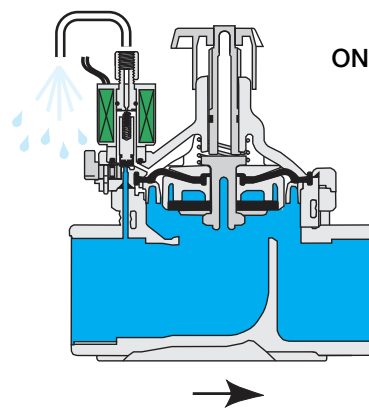

Open Position

The de-energized solenoid blocks the valve internal line pressure inlet and opens the drain port, venting the control chamber to the atmosphere, therefore fully opening the valve.

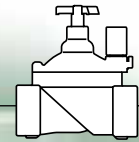

[1] **Fastening Bolts & Nuts**

6 Stainless Steel bolts and nuts fasten valve cover to body, ensuring quick in-line inspection and service.

[2] **Valve Cover (Hydraulic Type)**

Simple and light construction enables quick in-line inspection and service.

[2.1] Flow Stem

[3] **Auxiliary Closing Spring**

One single spring fully meets valve requirements for operating pressure range, ensuring low opening pressure and secured closing.

[4] **Seal Disk Assembly (Hydraulic Type)**

The seal disk assembly includes a flexible, carefully balanced, and peripherally supported diaphragm and a rugged guided plug with elastomeric sealing surface. This internal design enables:

- High flow rate with low head loss
- Smooth valve opening and closing
- Accurate and stable regulation
- Low opening and actuation pressure
- No diaphragm erosion and distortion
- Same diaphragm and spring fully meet the valve's operating pressure range requirements

[5] **Valve Body (Hydraulic Type)**

Glass-Filled Nylon to meet rough service conditions obtaining high chemical and cavitation resistance. Full bore seat with unobstructed flow path, free of any in-line ribs, supporting cage, or shafts

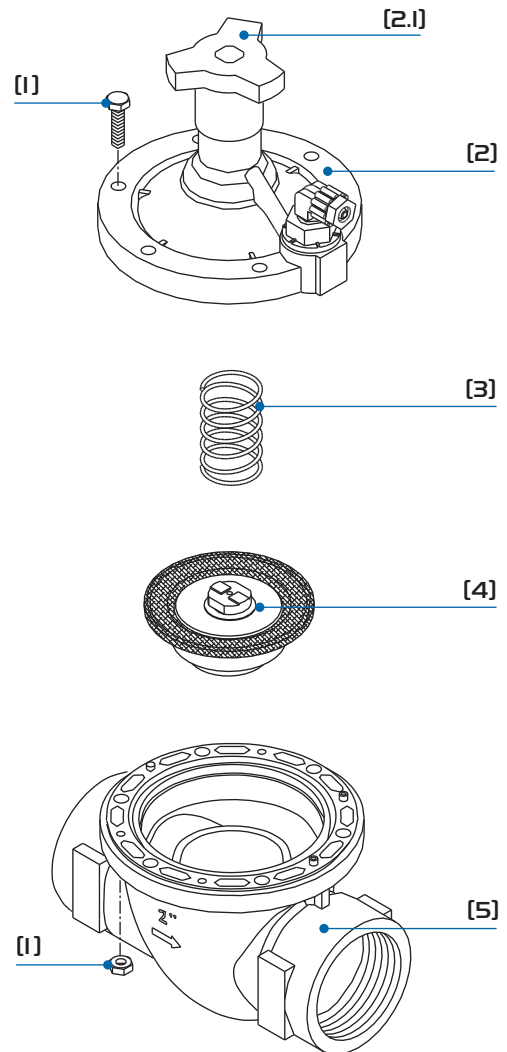

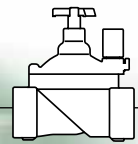

[1] Fastening Bolts & Nuts

6 Stainless Steel bolts and nuts fasten valve cover to body, ensuring quick in-line inspection and service.

[2] Valve Cover (Electric Type)

Simple and light construction enables quick in-line inspection and service.

[2.1] 2-Way Solenoid Actuator

[2.2] Manual Override Handle

[2.3] Needle - Restricts inlet flow & eliminates internal restriction clogging.

[2.4] Flow Stem

[3] Auxiliary Closing Spring

One single spring fully meets valve requirements for operating pressure range, ensuring low opening pressure and secured closing.

[4] Seal Disk Assembly (Electric Type)

The seal disk assembly includes a flexible, carefully balanced, peripherally supported diaphragm and a rugged guided plug with elastomeric sealing surface. This internal design enables:

- High flow rate with low head loss
- Smooth valve opening and closing
- Accurate and stable regulation
- Low opening and actuation pressure
- No diaphragm erosion and distortion
- Same diaphragm and spring fully meet the valve's operating pressure range requirements

[4.1] Internal Restriction

[5] Valve Body (Electric Type)

Glass-Filled Nylon to meet rough service conditions obtaining high chemical and cavitation resistance. Full bore seat with unobstructed flow path, free of any in-line ribs, supporting cage, or shafts.

[5.1] Internal Control Circuit Outlet

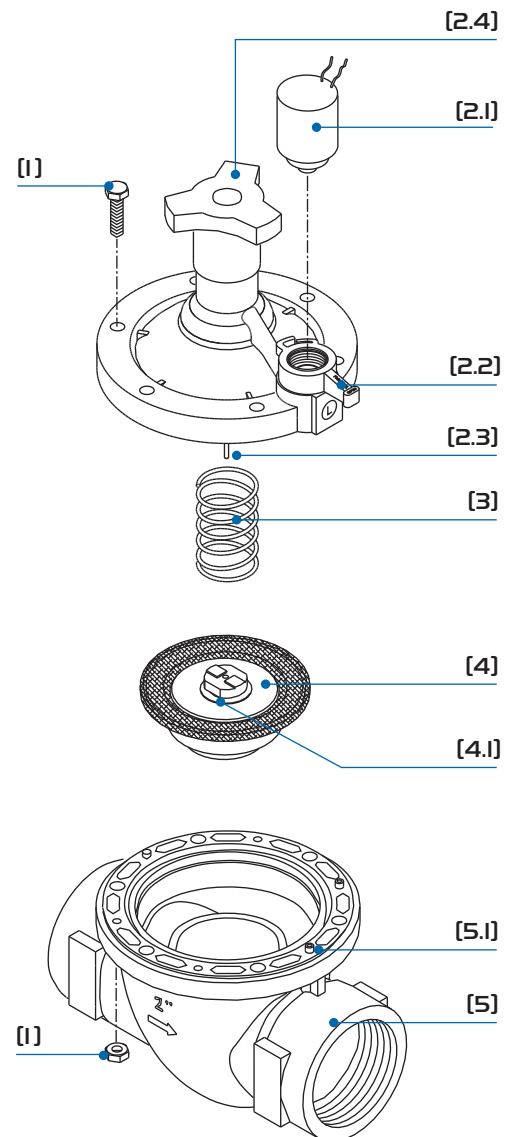

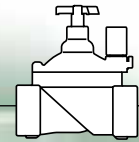

Dimensions & Weights

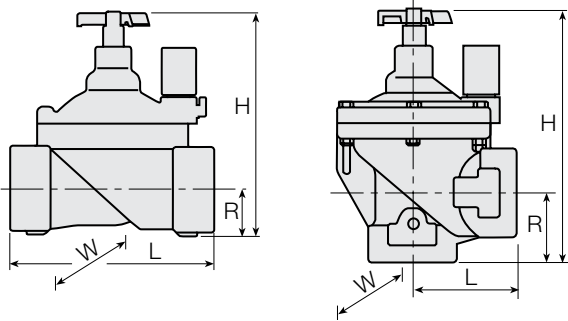

Pattern	Size	Globe				Angle	
		DN20	DN25	DN40	DN50	DN40	DN50
L	(mm)	110	110	160	170	80	85
H	(mm)	115	115	180	190	190	210
R	(mm)	22	22	35	38	40	60
W	(mm)	78	78	125	125	125	125
Weight*	(Kg)	0.35	0.33	1.0	1.1	0.95	0.91
CCDV**	(lit)	0.015	0.015	0.072	0.072	0.072	0.072

* Without flow control handle

**Control Chamber Displacement Volume (liter)

Technical Specifications

Available Patterns and Sizes:

Globe: DN: 20, 25, 40 & 50

Angle: DN: 40 & 50

Available End Connections:

BSP-T; NPT female threads

Pressure Rating: 10 bar

Operating Pressure Range: 0.7-10 bar

Standard Materials:

- Body and Cover: Nylon Reinforced
- Metal Parts: Stainless Steel
- Diaphragm: NBR [Buna-N]
- Seals: NBR [Buna-N]
- Spring: Stainless Steel
- Cover bolts: Stainless Steel

Flow Chart

2-Way circuit "Added Head Loss" (for "V" below 2 m/s): 0.3 bar

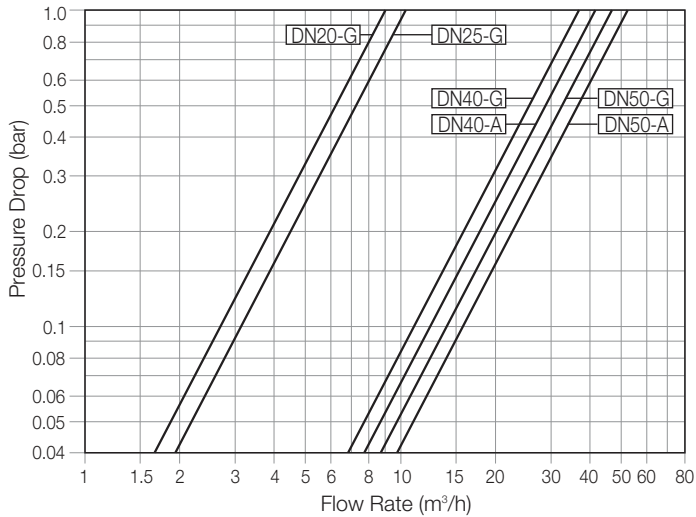

Pattern	Globe				Angle	
Sizes DN	20	25	40	50	40	50
KV (m³/h)	9	10.5	37	47	41	52

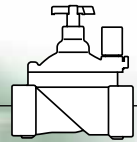

US English

Dimensions & Weights

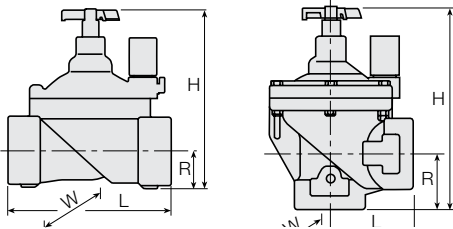

Pattern	Size	Globe				Angle	
		1/2"	1"	1 1/2"	2"	1 1/2"	2"
L	(inch)	4 ⁵ / ₁₆	4 ⁵ / ₁₆	6 ⁶ / ₁₆	6 ¹¹ / ₁₆	3 ³ / ₁₆	3 ³ / ₈
H	(inch)	4 1/2	4 1/2	7 1/8	7 1/2	7 1/2	8 1/4
R	(inch)	7/8	7/8	1 3/8	1 1/2	1 9/16	2 3/8
W	(inch)	3 ¹ / ₁₆	3 ¹ / ₁₆	4 ¹⁵ / ₁₆	4 ¹⁵ / ₁₆	4 ¹⁵ / ₁₆	4 ¹⁵ / ₁₆
Weight*	(lb)	0.77	0.73	2.2	2.4	2.1	2.0
CCDV**	(gal)	0.004	0.004	0.02	0.02	0.02	0.02

* Without flow control handle

**Control Chamber Displacement Volume (gallons)

Technical Specifications

Available Patterns and Sizes:

Globe: 3/4", 1", 1 1/2", 2"

Angle: 1 1/2", 2"

Available End Connections:

BSP-T; NPT female threads

Pressure Rating: 150 psi

Operating Pressure Range: 10-150 psi

Standard Materials:

- Body and Cover: Nylon Reinforced
- Metal Parts: Stainless Steel
- Diaphragm: NBR [Buna-N]
- Seals: NBR [Buna-N]
- Spring: Stainless Steel
- Cover bolts: Stainless Steel

Flow Chart

2-Way circuit "Added Head Loss" (for "V" below 6.5 f/s): 4.5 psi

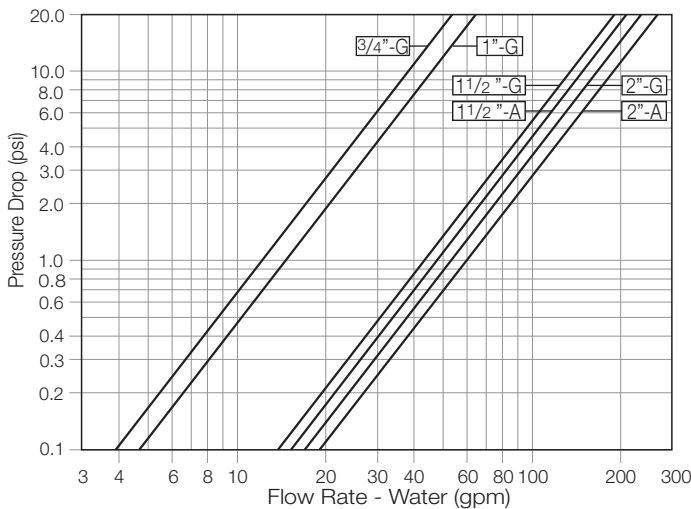

Pattern	Globe				Angle	
Sizes DN	3/4"	1"	1 1/2"	2"	1 1/2"	2"
CV (gpm)	10.4	12.1	42.7	54.3	47.4	60.1



Most engineers are familiar with defining control valves Main Features (Pressure Reducing, Pressure Sustaining, Pressure Reducing & Sustaining and etc.) Additional Features (Solenoid Controlled, Remote Hydraulic Control and etc.), as well as selecting the right application for Irrigation Project requirements.

The items below provide additional information for selecting the suitable control circuit type:

2-Way

3-Way

2/3 Way (Servo).

Consider the information below as a guide when selecting the control circuit type:

■ 2-Way Control

Use when very accurate control is required in clean filtered water supply or dirty water with sediments. Works well in dynamic or static flow condition. Note that applying a 2-Way control circuit has a small additional head loss across the valve in low and medium flow-rates ("V" below 2 m/s).

■ 3-Way Control (mark = X)

Use in applications where the water qualities can either be clean or dirty including some organic matter. 3-Way control will enable the valve to fully open if required during high flow irrigation shifts; when the valve is required to fully open with minimal head loss.

■ Servo 2/3-Way Control (mark = b)

Use in applications where the water qualities can either be clean or dirty with sediments or organic matter.

The Servo 2/3-Way pilot should be considered where extreme accuracy and regulation ability is required together with the possibility of dirty water. Especially recommended for pressure reduction of low pressure Drip-Tape (non compensated) irrigation systems.

Control Circuit Comparison:

2-Way Control Circuit Default

- Online accurate quick respond regulation
- Very low set point
- Very high accuracy
- restriction required
- small additional head loss across the valve in low and medium flow-rates ("V" below 2 m/s)

3-Way Control Circuit X

- Fully opens at low supply pressure

2/3-Way Control Circuit b

- Very low set point (drip-tape applications)
- Very high accuracy
- Dynamic integrated restriction
- Upstream pressure limit – 4 bar; 60 psi
- Small additional head loss across the valve in low and medium flow-rates ("V" below 2 m/s)

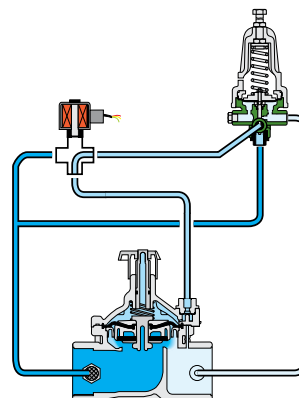
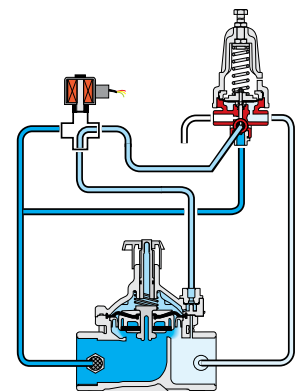
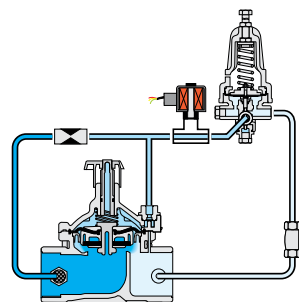

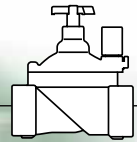

PC-20-A-P, Plastic - 2-Way Pressure Reducing Pilot Valve

This pilot integrates all principal functions of a 2-Way control circuit into a single assembly. It is a direct acting pilot valve, actuated by a pressure responsive diaphragm, which seeks to reach equilibrium between hydraulic and set spring forces. When used in a pressure reducing circuit, the pilot modulates to the closed position as downstream pressure rises above set point. An internal restriction acts as an upstream flow restrictor.

Setting Range Table

Spring	Set Pressure	
	bar	psi
N-Natural	0.8-6.5	11-95
K-Grey	0.5-3	7-40

Connections

- 1 or 2 - Downstream / Remote sensing
- 3 - Valve control chamber
- 4 - Upstream

* Other spring types available on request.

NEW



PC-X-A-P, Plastic - Positioning 3-Way Pilot Valve

This multi-purpose, direct acting 3-Way positioning pilot valve is actuated by a pressure responsive diaphragm, which seeks to reach equilibrium between hydraulic and set spring forces.

The pilot directs flow and pressure between its ports:

- When sensed pressure is above set point, it connects port 0 to port 3.
- When sensed pressure is equal set point, it blocks connections between all ports.
- When sensed pressure is below set point, it connects port 3 to port 2.

Relevant pressure is continuously sensed through port 1.

Setting Range Table

Spring	Set Pressure	
	bar	psi
N-Natural	0.8-6.5	11-95
K-Grey	0.5-3	7-40

Connections

- 0 - Upstream for reducing, Vent for sustaining
- 3 - Valve control chamber
- 2 - Vent for reducing, Upstream for sustaining
- 1 - Pressure Sensing

* Other spring types available on request.

NEW



PC-S-A-P, Plastic - Pressure Reducing Servo Pilot Valve

This pilot combines all principal functions of a 2-Way control circuit with elements of a 3-way control circuit. It is a direct acting pilot valve, actuated by a pressure responsive diaphragm, which seeks to reach equilibrium between hydraulic and set spring forces. A fully balanced trim ensures high accuracy and stability.

Setting Range Table

Spring	Set Pressure	
	bar	psi
K-Grey	0.5-3	7-40
J-Green	0.2-1.7	3-25

Connections

- 0 - Upstream for reducing
- 1 or 2 - Downstream / Sensing
- 3 - Valve control chamber

* Other spring types available on request.

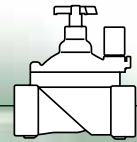

S-390-2W

2-Way Solenoid Actuator

Actuator Type	Cable Color	Power (Watt)	Current (Amp)		Coil Resistance ohm@20°C; 68°F
			Inrush	Hold	
S390-2W-24VAC-R	Red/Red	1.7	0.25	0.125	37.5
S390-2W-24VAC-D	Red/Orange	2.2	0.13	0.13	*
S390-2W-24VDC	Black/Black	3.6	0.18	0.18	156
S390-2W-12VDC	Blue/Blue	4.0	0.33	0.33	36



S-390-3W

3-Way Solenoid

Actuator Type	Cable Color	Power (Watt)	Current (Amp)		Coil Resistance ohm@20°C; 68°F
			Inrush	Hold	
S-390-3W-24VAC-D NO	Red/Orange	2.2	0.13	0.13	37.5
S-390-3W-24VAC-D NC	Orange/Blue	3.5	0.20	0.20	*
S-390-3W-24VAC-R NO	Red/Red	2.9	0.46	0.24	21
S-390-3W-24VDC NO & NC	Black/Black	4.2	0.17	0.17	135
S-390-3W-12VDC NO & NC	Blue/Blue	4.0	0.33	0.33	36



S-400-3W

3-Way Solenoid with Hydraulic Plastic Base

Actuator Type	Cable Color	Power (Watt)	Current (Amp)		Coil Resistance ohm@20°C; 68°F
			Inrush	Hold	
S-400-24VAC-D-NO	Red/Blue	3.5	0.20	0.20	*
S-400-24VAC-D-NC	Red/Blue	3.5	0.20	0.20	*
S-400-24VAC-R-NO	Red/Red	3.5	0.60	0.30	14
S-400-24VAC-R-NC	Red/Red	3.5	0.60	0.30	14
S-400-24VDC-NO	Black/Black	4.2	0.17	0.17	135
S-400-12VDC-NO	Blue/Blue	4.0	0.33	0.33	36



* Coil resistance in these coils cannot be measured

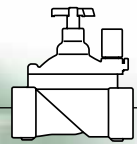

S-392-2W

2-Way Magnetic Latch Solenoid Actuator, 9VDC Latch, 2- Leads

Electrical Data:

Voltage Range: 6-20 VDC
Coil Resistance: 6Ω
Coil Inductance: 90 mH
Pulse Width: 20-100 mSec.

Required Capacitor: 4700μF
Operation Modes (electrical connections):
+Red & -Black: Latch Position
+Black & -Red: Released Position



S-402-3W

3-Way Magnetic Latch Solenoid Hydraulic Base, 9-40VDC Latch, 2- Leads

Electrical Data:

Voltage Range: 9-40 VDC
Coil Resistance: 6Ω
Coil Inductance: 90 mH
Pulse Width: 20-100 mSec.

Required Capacitor: 4700μF
Operation Modes (electrical connections):
+Red & -Black: Latch Position
+Black & -Red: Released Position



S-982-3W

3-Way Dry Magnetic Latch Solenoid with Isolating Membrane & Hydraulic Base, 12VDC Latch, 2- Leads

Electrical Data:

Voltage Range: 12-50 VDC
Coil Resistance: 4.2Ω
Pulse Width: 20-100 mSec.

Required Capacitor: 4700μF

Operation Modes (electrical connections):

+ Red & - Black: Solenoid vents
+ Black & - Red: Solenoid pressurizes

Pressure & Flow Data:

Operating Pressure Range: 0-10 bar

Base Orifice Diameter: 2.2 mm

Base Flow Factor:

Pressure port $K_v = 0.12 \text{ m}^3/\text{h} @ 1 \text{ bar } \Delta P$

$C_v = 0.14 \text{ GPM} @ 1 \text{ psi } \Delta P$

Exhaust port $K_v = 0.14 \text{ m}^3/\text{h} @ 1 \text{ bar } \Delta P$

$C_v = 0.16 \text{ GPM} @ 1 \text{ psi } \Delta P$

**Connections:**

1- Vent 2- Valve Control Chamber 3- Pressure

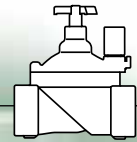

IR-205-MZ

Infield Head-Works with Auto Metering Valve (AMV), Fertilizer Valve, Filter and 3 Hydraulic Control Valves with Flow Stem and Manual Selector

The Model IR-923-D, pressure reducing and sustaining AMV is manually set to supply preset water volume for irrigation. The three Plastic Hydraulic Control Valves, Model IR-205-MZ, allow:

- Easy manual control of individual irrigation set using the manual selector.
- Simple flow / pressure control by the manual flow stem.
- Optional connection to future automation system.



IR-210-6-20DC-2W-M

Infield System with two Latch Solenoid Controlled Valves with Flow Stem and Manual Opening

The two BERMAD Plastic Solenoid Controlled Valves with 2-Way Internal Control, Model IR-210-9DC-2W-M, allow:

- Remote control of individual irrigation sets using battery operated controller or radio operated RTU.
- Simple flow / pressure control by the manual flow stem.
- Manual local opening of the valve by the "Orange" handle.

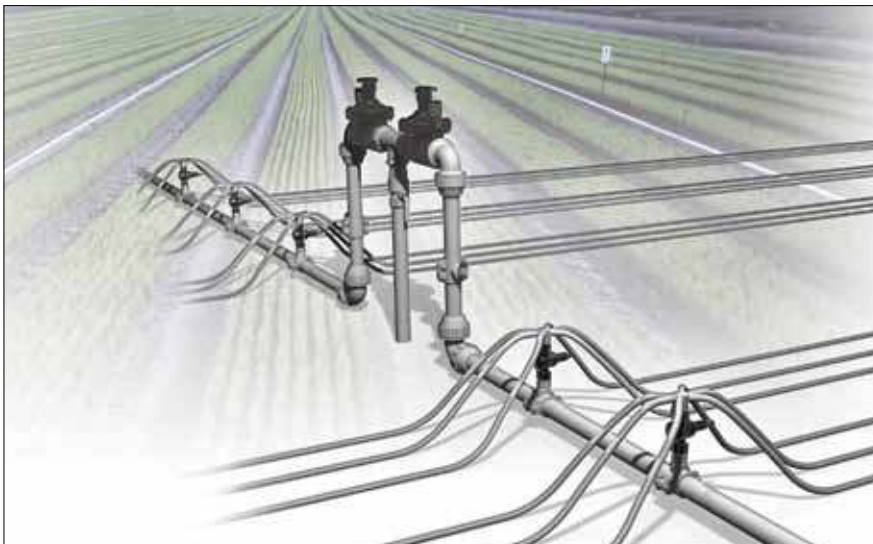

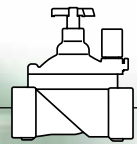

IR-220-bZ-M

Infield Head-Works with Main On-Off Solenoid Control Valve and Four Pressure Reducing Control Valves with Flow Stem and Manual Selector

BERMAD Model IR-110-2W-NM opens in response to electric signal. The Four BERMAD Models, **IR-220-bZ**, establish four different reduced pressure zones, protecting irrigation laterals and distribution line.

The unique low pressure requirements and sensitivity of laterals in Drip-Tape projects demand special care in the selection and functioning of Pressure Reducing Valves.

Equipped with Servo Pilot, BERMAD Pressure Reducing Valves for Drip-Tape Applications provide a very low set point (0.5 bar; 7 psi) and a dynamic integrated needle valve resulting in very high accuracy and pressure repeatability.



IR-220-55-b-M

Infield Head-Works with Four Pressure Reducing Solenoid Controlled Valves with Flow Stem and Manual Selector

Saving the need for an additional main valve, each of the four “Shift Control” valves, BERMAD Model **IR-220-55-b**, open in response to electric signal and establishes four different reduced pressure zones, protecting irrigation laterals and distribution line. The Solenoid includes manual override to allow local opening and closing of each valve.



Europe • Asia • Australia • Africa • America

BERMAD Worldwide

With representation on every continent and across some 86 countries, BERMAD is an undisputed world leader in control valves, maintaining broad training and parts distribution networks all over the globe.

Wherever your location, BERMAD is there.

BERMAD International Head Offices:

- BERMAD Australia
- BERMAD Brazil
- BERMAD Chile
- BERMAD China
- BERMAD Colombia
- BERMAD Italy
- BERMAD Mexico
- BERMAD Peru
- BERMAD UK
- BERMAD USA



Irrigation
Hydraulic
Control Valves

info@bermad.com • www.bermad.com

BERMAD Water Control Solutions

BERMAD
Waterworks

BERMAD
Fire Protection

BERMAD
Petroleum

BERMAD
Irrigation

BERMAD
Landscape



info.cn@bermad.com • www.bermad.com

The information herein is subject to change without notice. BERMAD shall not be held liable for any errors. All rights reserved.
© Copyright by BERMAD