

Pressure Management Valve, Flow Compensated Pressure Reducing Valve

(Sizes 1½-16"; DN40-400)

Description

The model 7PM Pressure Management Valve is a hydraulically operated, diaphragm actuated control valve that automatically and continuously optimizes downstream pressure, correlating valve setting with demand.

Installation

1. Ensure enough space around the valve assembly for future maintenance and adjustments.
2. Prior to valve installation, flush the pipeline to insure flow of clean fluid through the valve.
3. For future maintenance, install Isolation gate valves upstream and downstream from Bermad control valve.
4. Install the valve in the pipeline with the valve flow direction arrow in the actual flow direction. Use the lifting ring provided on the main valve cover for installing the valve.
5. For best performance, it is recommended to install the valve horizontally and upright. For different valve positions – consult Bermad.
6. After installation carefully inspect/correct any damaged accessories, piping, tubing, or fittings.
7. Install pressure gauges (instead of the plastic plugs on the control trim).
8. It is highly recommended to install a strainer Bermad model 70F upstream from the 7PM, to prevent debris from damaging valve operation.
9. Install a flow meter between the strainer and the 7PM (follow manufacturer installation instructions).

Commissioning & Calibration

1. The model 7PM is factory set according to the design pressure and flow. The set values are marked on the label.
Caution: Prior to exposing the 7PM to line pressure, confirm that the Cam Assy. [66], [67] & [76] is locked 3-5mm above the valve Indicator upper plug [68]. Use the Shim [79] as a gauge. If required, open the Socket Screws [76] using a 3mm Allen key, calibrate the Cam location and lock the Socket Screws.
2. [Control Drawing] Confirm that cock valves [1], [2] & [3] are open (handle parallel to cock-valve body).
3. Open fully the upstream isolating valve and partially the downstream isolating valve, to fill-up, in a slow and controlled manner, the consumers line downstream from the pressure reducing system.
4. Vent air from the valve's control loop by loosening cover tube fitting at the highest point, allowing all air to bleed. Retighten the tube fitting eyebolt.
5. Low pressure setting
 - 5.1. Confirm that the flow through the valve is the minimum night flow. If necessary, increase or decrease the flow by adjusting the downstream isolating valve. The cam [66] should not touch the roller [60].
 - 5.2. Allow the pressure that appears in the downstream pressure gauge to stabilize, meeting the marked minimum set pressure.
 - 5.3. If the set pressure is either different from the design or the requirements have been changed, unlock the low pressure setting bolt lock nut [74L] and slowly turn the low pressure setting bolt [72] Clock-Wise to increase set pressure and Counter-Clock-Wise to decrease it. Allow the 7PM to react and the pressure to stabilize.
 - 5.4. After the pressure is stabilized, lock the low pressure setting bolt lock nut [74L].
6. High pressure setting
 - 6.1. Pull the roller assembly ring [73] and slide the shim [79] into the side grooves[79.1]. Release the ring ensuring that the roller is leaning on the shim.
 - 6.2. Allow the pressure that appears in the downstream pressure gauge to stabilize, meeting the marked maximum set pressure.
 - 6.3. If the set pressure is either different from the design or the requirements have been changed, unlock the high pressure setting lock nut [74H] and slowly turn the high pressure setting nut [80] Counter-Clock-Wise to increase set pressure and Clock-Wise to decrease it. Allow the 7PM to react and the pressure to stabilize.
 - 6.4. After the pressure is stabilized, lock the high pressure lock nut [74H] and remove the shim [79].

7. Flow compensation setting
 - 7.1. Increase the flow by opening the downstream isolating valve to the average flow. If necessary, create flow by opening a hydrant.
 - 7.2. Allow the pressure that appears in the downstream pressure gauge to stabilize, meeting the average pressure. The roller [60] should be located on the cam [66] slope.
 - 7.3. If the average flow and pressure values requirements have been changed, unlock the cam lock nut [67], (if required - insert a screwdriver in one of the cam holes) and slowly turn the cam [66] upwards to increase average pressure and downwards to decrease average pressure. Allow the 7PM to react and the pressure to stabilize and lock the cam lock nut.
8. The Restriction [31] enables the 2-Way control & reduces valve closing speed.
9. The One Way Flow Control [19] is factory set fully open. To decrease opening speed or to stabilize the valve reaction, turn the needle valve CW.

Assembly Drawing

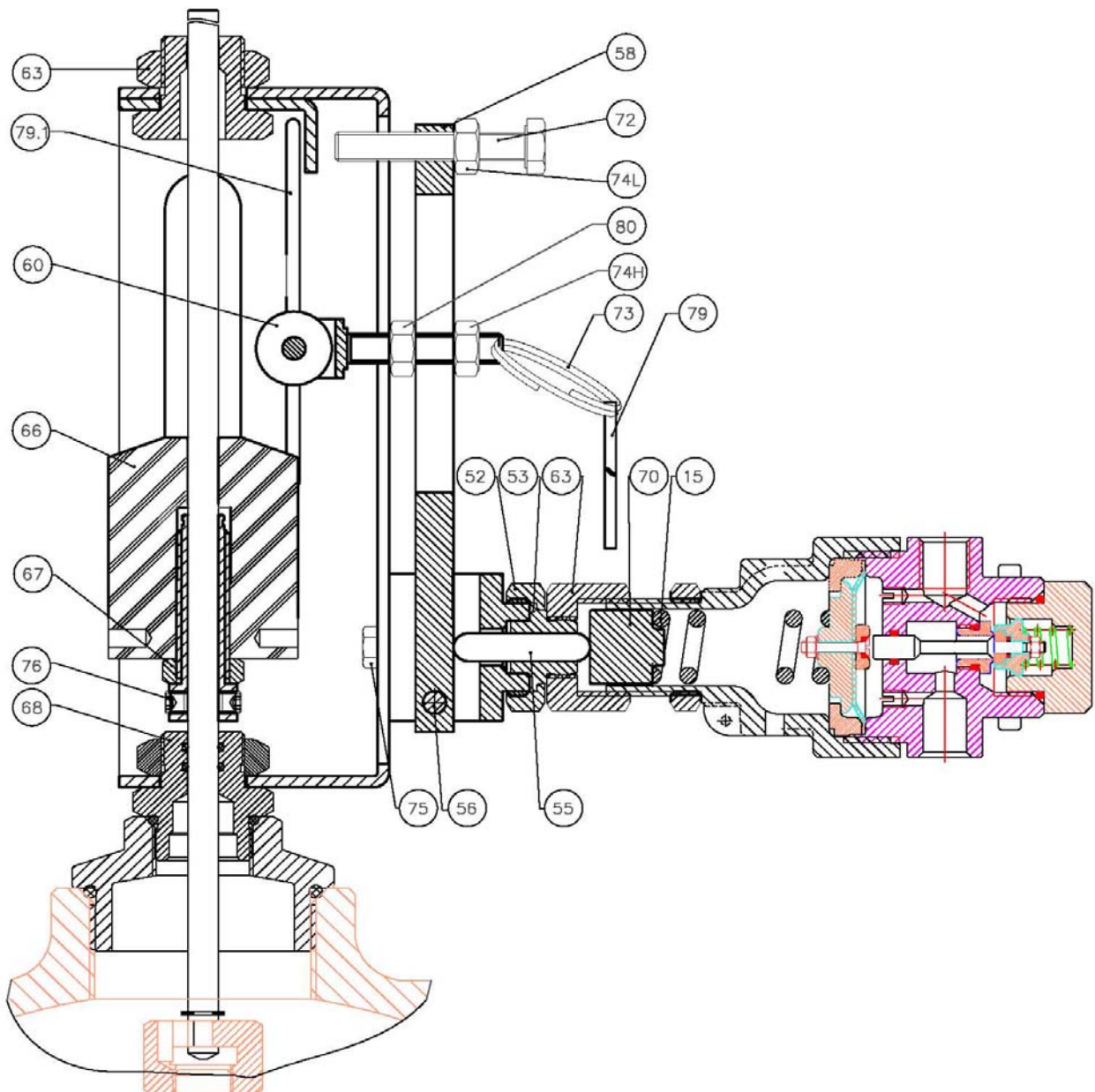

Control Drawing

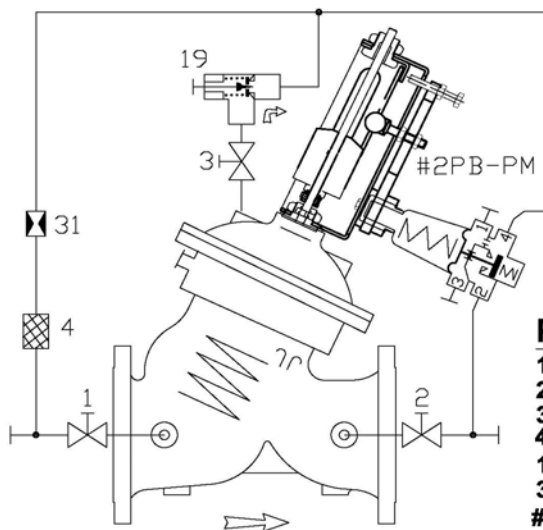

PARTS LIST

1	2W Cock Valve
2	2W Cock Valve
3	2W Cock Valve
4	Control Filter
19	One Way Flow Control MT Type
31	Restriction Orifice
#2PB-PM	2W PB PR Pilot For Pressure Management

Trouble-Shooting

- Valve fails to Open:** Check for sufficient inlet pressure, create demand/flow, confirm settings & check cock valves status.
- Valve fails to Close:** Create demand/flow, confirm settings, check needle & cock valves status, clean control filter & detect for clogged ports or fittings, check if any debris trapped in the main valve, confirm diaphragm is not leaking.
- Valve fails to Regulate:** Check needle valves setting, release air trapped in the control chamber & check cock valves status.

Preventative Maintenance

- System operating conditions that effect on the valve should be checked periodically to determent the required preventative maintenance schedule.
- Maintenance instructions:
 - Tools required:
 - Metric and imperial wrenches
 - Anti seize grease
 - Visual inspection to locate leaks and external damages
 - Functional inspection including: closing, opening and regulation.
 - Close upstream and downstream isolating valves (and external operating pressure when used).
 - Once the valve is fully isolated vent pressure by loosening a plug or a fitting.
 - Open the stud nuts and remove the actuator as one unit from the valve body. Disassemble necessary control tubs.
 - It is highly recommended to stock a reserve actuator assembly for each size. This allows minimum system field work and system down time.
 - Disassemble the actuator and examine its parts carefully for signs of wear, corrosion, or any other abnormal conditions.
 - Replace worn parts and all the Elastomers. Lubricate the bolts and studs threads with Anti seize grease.

Spare parts

Bermad has a convenient and easy to use ordering guide for valve spare-parts and control system components. For solenoid valves refer to model and S/N on solenoid tags.

Pub # : IOMEW7PM

By: YE 1/09

Rev: 02YE-6/09

File name: IOMEW7PM_06_09

appliceng@bermad.com • www.bermad.com

The information contained in this document is subject to change without notice.

BERMAD shall not be liable for any errors contained herein. All Rights Reserved. © Copyright by BERMAD Control Valves.