

Burst Control Valve Excessive Flow

Model MN-790-M

Hydraulically operated, flow control valve that upon sensing flow in excess of setting, shuts off and locks drip tight, until it is manually reset. As long as the flow is lower than the setting, the valve remains fully open, minimizing head loss.

Bermad 700 Series valves are hydraulic, pilot operated, oblique pattern, globe valves with a seat assembly and double chamber unitized actuator that can be disassembled from the body as a separate integral unit.

The valve's hydrodynamic body is designed for unobstructed flow path and provides high flow capabilities.

The 700 Series operate under difficult operation conditions with minimal cavitation and noise. They are made of the highest quality materials suitable for different mining applications.



Features and Benefits

- Hydraulic flow sensor
 - No moving parts. No electronic components.
 - No need for flow straightening
- Designed to stand up to the toughest conditions
 - Tamper resistant
 - High sensitive pilot requires minimal valve - ΔP
 - Drip tight sealing
- Double chamber actuator design
 - Protected diaphragm
 - No spring - full opening
 - Simplified maintenance as it can be removed as a single unit. In-line serviceable
- Flexible design - Easy addition of optional features
- Obstacle free flow path

Major Additional Features

- Closing at pressure drop - **790 - 91**
- Solenoid control - **790 - 55 - M**
- Pressure Reducing - **792 - U**
- Electric override - **790 - 59 - M**

See relevant BERMAD publications

List of Components:

- [1] Burst Control Valve 790
- [2] Strainer 70F
- [3] Combination Air Valve C70

Typical Installation

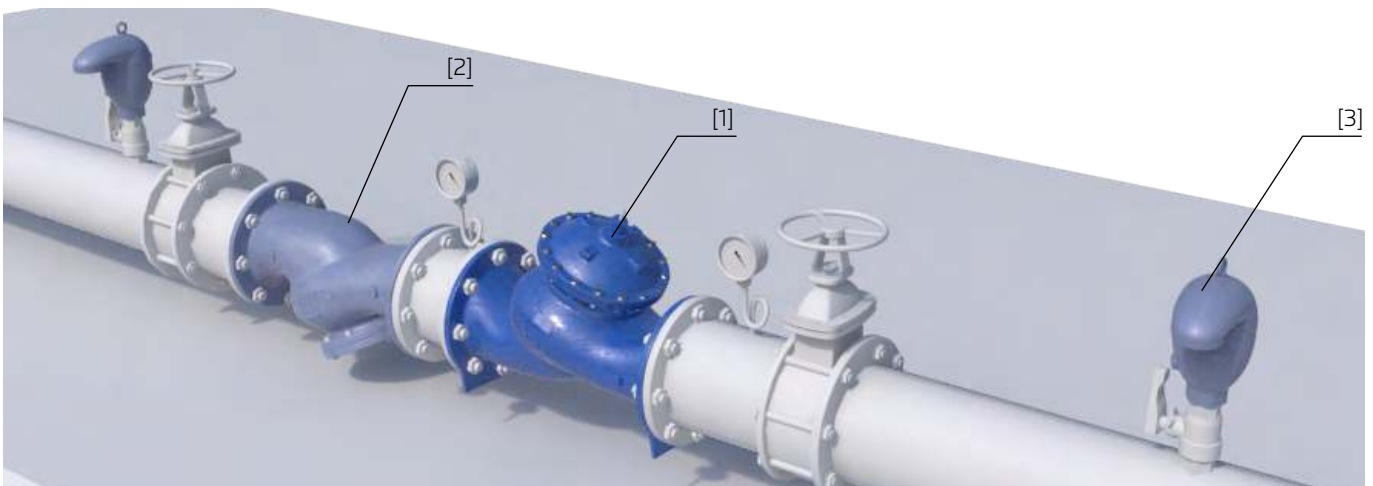

All images in this catalog are for illustration only

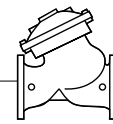

Control Schematic (*)

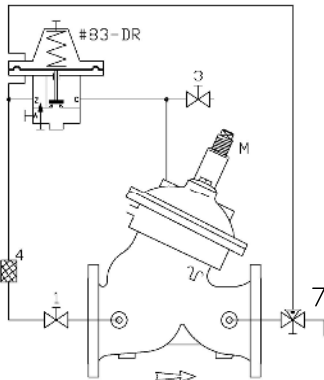

Standard Configuration

- 1 2W Isolation Valve
- 3 2W Manual Reset Valve
- 4 Control Filter
- 7 3W Manual Test Valve
- #83-DR 2W High Sensitivity Press. Sustaining Pilot
- M Flow Stem

Additional features (OPTIONAL)

- F Large Control Filter
- F1 Extra Large Control Filter
- 6 Pressure Gauge
- I Visual Position Indicator
- S Electric Limit Switch

(*) As a reference only. Components may vary based on valve's size and class.

Operation

- Model MN-790-M is equipped with an adjustable, high sensitivity, differential pressure sustaining pilot. The pilot senses valve differential pressure.
- Should this differential pressure rise above the pilot setting, it opens, introducing upstream pressure into the upper chamber, causing the main valve to begin an irreversible "close & lock" process.
- Once the valve is closed, it only can be opened manually through the manual reset valve. When differential pressure is below the pilot setting, the pilot blocks upstream pressure from the control chamber, and the main valve remains fully open.
- Manual test valve enables simulation of burst conditions and valve response. The Mechanical Flow Stem enables adjustment of the closing point to meet various flow regimes.

Altitude Pilot Options:

- Various pilots and calibration springs are available. Select according to valve size and operation conditions. For more details check pressure sustaining pilots (modified to differential sensing and high sensitivity) product pages.
- Pilot Adjustment Range:



Pilot Code	feet	meter
M6	7-46	2-14
M5	17-72	5-22
M4	49-115	15-35
M8	82-230	25-70

Pressure Rating

	Class 150			Class 300		
Max. Recommended Pressure	250 PSI			400 PSI		
Available End Connection	Flanged ANSI#150	Grooved ANSI/AWWA C606	Threaded	Flanged ANSI#300	Grooved ANSI/AWWA C606	Threaded

Materials

Components		Water Applications	Thermal Shock Applications	Base Solutions Applications	Acid Solutions Applications (**)
Main Valve	Body & Cover	Ductile Iron	Carbon Steel	Ductile Iron	Stainless Steel 316
	Internals	Stainless Steel	Stainless Steel	Stainless Steel	Stainless Steel 316
		Brass/Coated Steel	Brass/Coated Steel	Coated Steel	
	Elastomers	Synthetic rubber	Synthetic rubber	Synthetic rubber	Viton
Coating	Fusion Bonded Epoxy	Fusion Bonded Epoxy	Fusion Bonded Epoxy	Uncoated	
Pilot	Body	Brass/Bronze	Brass/Bronze	Stainless Steel 316	Stainless Steel 316
	Internals	Stainless Steel	Stainless Steel	Stainless Steel 316	Stainless Steel 316
		Brass	Brass		
Elastomers	Synthetic rubber	Synthetic rubber	Synthetic rubber	Viton	
Control Loop Accessories	Accessories	Brass/Bronze	Stainless Steel 316	Stainless Steel 316	Stainless Steel 316
	Tubing & Fittings	Brass	Stainless Steel 316	Stainless Steel 316	Stainless Steel 316

(**) For highly aggressive acid solutions: Super Duplex, Hastelloy C-276, SMO-254 6-MO. Others by request.

Notes:

- Inlet pressure and flow rate are required for optimal sizing.
- Maximum recommended flow velocity: 6m/sec; 18ft/sec. Intermittent: 7.5m/sec; 21ft/sec.
- Minimum operating pressure: 0.7 bar / 10 PSI. For lower pressure requirements consult factory.

