



## Pressure Relief Valve

### Model FP-3HC

The BERMAD FP-3HC is direct acting diaphragm type, Pressure Relief/ Pressure Sustaining Valve.

The single port is actuated by a pressure responsive, spring loaded diaphragm, which tends to reach equilibrium with the adjustable pre-set spring force, thereby relieving or sustaining the chosen pre-set inlet/ upstream pressure value.

When the FP-3HC installed in a Relief/Sustaining circuit, it automatically modulates to open as upstream pressure reaches the chosen set point.

#### Features

- Internal pressure sensing
- Remote sensing, optional

#### Typical Applications

- Direct-Acting Water Pressure Relief Valve (model FP-3HC)
- Pilot valve for Relief Valves sizes 12-16" (model #3HC-R)
- Pilot valve for Differential Pressure Sustaining Valves sizes 12-16" (model #3HC-DR)

#### Technical Data

- Process connections: 1/2" NPT or 3/4" ISO-7 Rp
- Pressure Rating: 25 bar (365 psi)
- Working Temperature: Water up to 80°C (180°F)

#### Standard Materials

- Body & Cover: Stainless Steel
- Elastomers: NBR
- Internals: Stainless Steel & Brass
- Spring: Galvanized Steel

#### Optional Materials:

- All Stainless Steel 316, CF8M Body
- Nickel Aluminum Bronze ASTM B148 C95800
- Super Duplex S.S.

#### Adjustment Range

Spring	Pressure		
	bar	psi	
16	1-16	15-235	Standard
25*	2-25	30-365	Optional

\* With high pressure setting kit

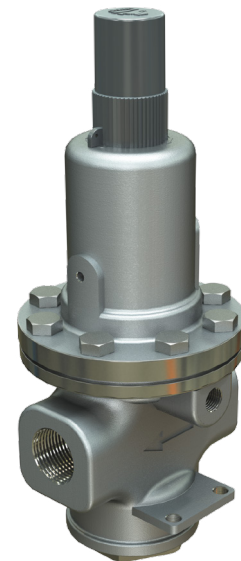

(for Illustration Only)

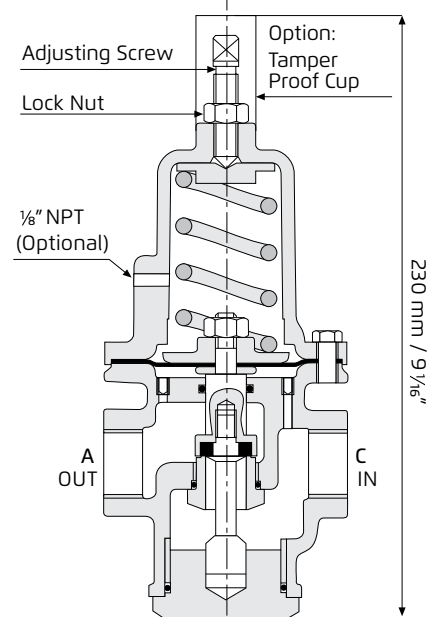
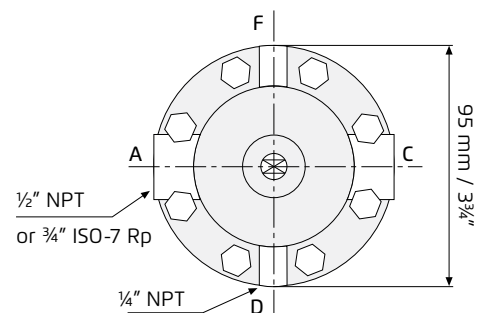

**Weight: 3.4 Kg / 7.5 lbs.**

\* High pressure setting kit add 128 mm (5") to pilot height

