

Fire Line Basket Strainer

Model FP-60F

The BERMAD FP-60F Basket Strainers are designed to be installed in fire protection pipelines primarily to prevent the clogging of fire system nozzles of automatic sprinklers, deluge spray or foam systems.

The FP-60F strainers are also well suited for use upstream of BERMAD Pressure Control Valves and Deluge valves as well as other pipeline debris sensitive Fire System Devices.

The ratio of the FP-60F strainer's basket area to its inlet pipe area is larger than 10:1, ensures continued system performance even in the most debris-ridden firewater.

The high capacity of the FP-60F also results in a lower pressure drop and enables longer intervals between cleaning and servicing.

The BERMAD FP-60F is designed for in-line maintenance with easy access, requiring only the top cover removal for basket screen cleaning or without removing the main strainer housing body from the pipeline.

NFPA 11, 13, 15 and 16 standards state that listed strainers shall be provided in the main pipeline of all systems using nozzles with waterways less than 3/8" (9.5mm) and for any system where the water is likely to contain obstructive material. Strainers shall be capable of removing all solids of sufficient size to obstruct fire protection devices and equipment waterways.



Features and Benefits

- **UL-Listed and ULC size** for Fire system
- **Low pressure drop** – Safety and reliability, ensures firewater availability
- **Easy in-line maintenance** - Top cover removal for cleaning without removing strainer body from the pipeline
- **Suitable to prevent clogging** - Nozzles, sprinklers or other types of fire system discharge outlets. Designed to trap foreign material of 3.2mm (1/8") diameter or larger
- **Large screen basket** – Large basket area, Increasing system reliability and safety
- **Suitable for installation in any position** - Refer to installation and maintenance section
- **Compatible for use with corrosive fluids and harsh environments** – High Build Epoxy coated body/cover and stainless steel 316 screen
- **Suitable for Foam Systems** – complies with the NFPA-11 requirements, to be used with foam proportioner / generator, provided in the water line upstream of the deluge valve

Approvals

**UL-Listed
Strainers, Pipeline (HLCV. EX26794)**

**ULC Certified for Canada
Strainers, Pipeline (LCV7.EX26794)**

Typical Applications

- Automatic water spray systems
- Deluge systems
- Automatic sprinkler systems
- Foam proportioner/generator provided in the water line
- Upstream of Pressure Control valves
- Upstream of a Sensitive System Devices

Options

Consult BERMAD for other Material of Constructions or other available specifications.

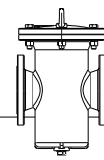

Design Engineer Guide

The BERMAD FP-60F Basket strainers are for use in firewater supply and are capable of preventing the entrance of solids of sufficient size that might block or clog the fire protection nozzles or other devices sensitive to debris contaminated firewater.

Install the FP-60F strainer upstream of the sprinkler valve, deluge valve, pressure control valve or any other debris sensitive system device.

The Strainer must be located where there is adequate clearance for complete removal of the basket screen assembly to enable easy extraction and cleaning of the strainer basket. Take into consideration the release of water when draining the entire volume of the strainer and piping, as is required before maintenance or inspection.

The drain connection should be typically fitted with an appropriately sized normally closed valve and drain piping.

The 60F Basket Strainers are recommended to install in horizontal position with the strainer cover facing upwards, however Strainers are suitable to be installed in any position.

The strainers shall be installed and maintained in compliance with the NFPA-25 standard in the addition to the authorities heaving jurisdiction instruction.

The NFPA-11 standard required that a listed strainer with basket screen area to pipe cross-sectional area 10:1 ratio shall be used with foam proportioner or foam generator, and should be installed in the water pipeline upstream of the water control valve.

The NFPA 13, 15 and 16 standards require that a Listed Strainer shall be provided in the main pipeline of all systems utilizing nozzles with waterways less than 3/8" (9.5 mm) and for any system where the water is likely to contain obstructive material. Strainers shall be capable of removing from the water all solids of sufficient size to obstruct the nozzles.

Engineer Specifications

The Fire Line Strainer shall be a basket type strainer UL listed for 14 bar/200 psi.

The strainer shall be with high flow capacity and low pressure loss.

The strainer body and cover shall be ductile iron ASTM A536 65-45-12 with anti-corrosion Fusion Bonded High Build Epoxy RAL 3002 coating internally and externally, all other wetted parts shall be stainless steel 316.

The screen shall be inline removable basket type, made of stainless steel 316 with screen holes diameter of 3.2 mm (1/8"), meeting the requirements of the NFPA codes and standards. The Strainer basket screen area shall be at least 10:1 compared to the cross-sectional area of the pipeline.

Strainer maintenance, inspection or service shall be carried out in-line and without disassembly of the strainer body from the pipeline. The Strainer shall be supplied pre-assembled with stainless steel bolting, hydraulically tested by a factory certified to ISO-9001 standard.

Typical Installations

Deluge / Sprinkler System (see illustration)

The BERMAD FP-60F strainer should be installed upstream of the Deluge, Foam system or Automatic Sprinkler system, preventing debris particles from clogging the nozzles.

Automatic Pressure Control System (see illustration)

The BERMAD FP-60F strainer is ideal to be installed upstream of the BERMAD Pressure Control Valve, preventing the fouling of valve sealing surfaces and keeping the waterways clear from obstructions.

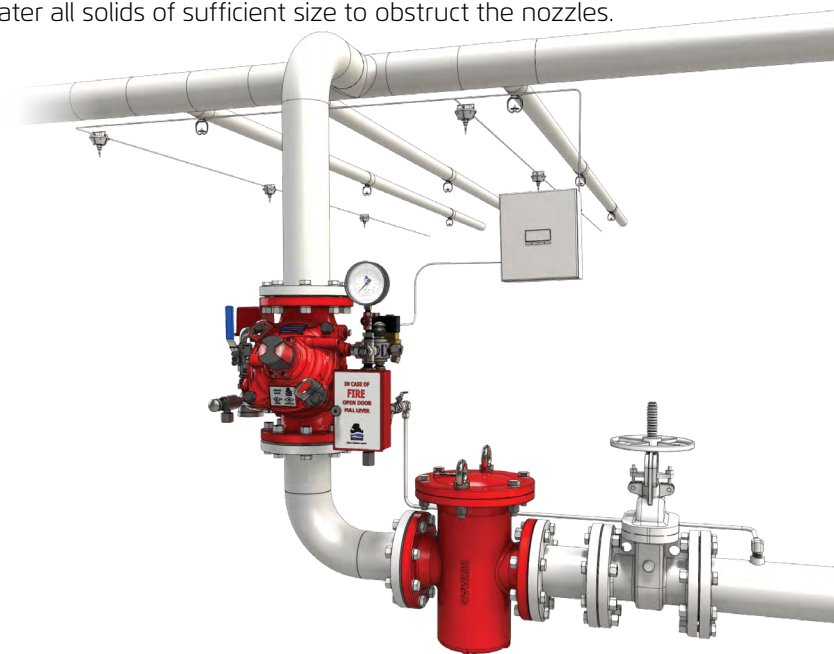

Deluge / Sprinkler System

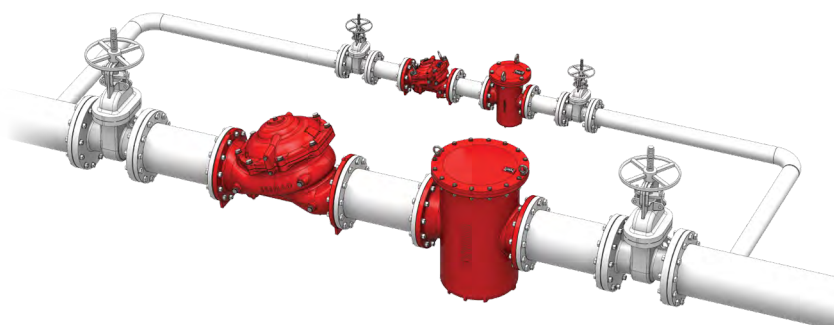

Automatic Pressure Control System
Parallel installation for redundancy or low flow bypass

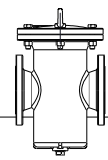

Installation

Provide basket removal clearances and strainer installation provisions in accordance with the requirements given in the Design Engineer Guide section above. Install the strainer with the flow arrow on the body pointing in the desired flow direction.

The strainer shall be installed on the pipeline upstream of the sprinklers, pressure control valve, deluge valve or other sensitive system device. Install a listed isolating valve upstream of the strainer. An adequate support shall be provided to carry the system installation as well as the dynamic loads.

It is recommended to install a differential pressure gauge rooted to upstream and downstream of the FP-60F-01 strainer, in order to show strainer blockage, if maximum allowable pressure differential of 7 psi (0.5 bar) across the strainer screen has exceeded the maximum system flow rate.

Placing In Service

Verify that all strainer cover bolts are well tightened, close the drain plug and/or drain valve, slowly open the supply-isolating valve and check that there are no leakages. Observe the system pressure gauge: it should indicate that the normal supply of water pressure is maintained.

Maintenance

The following inspection procedure must be performed as indicated, in addition to specific requirements of any applicable standards. Any damage or performance deficiency must be immediately corrected.

In addition to the authority having jurisdiction the owner is responsible for the inspection, testing, and maintenance of their fire protection system and devices in compliance with this document, as well as with the applicable standards of the NFPA 25 code.

The fire system shall be inspected, tested, and maintained by qualified service personnel in accordance with local requirements and/or national codes.

NOTES: A clear permission to shut down the affected fire protection system must first be obtained from the proper authorities. All personnel who may be affected by this action must be notified prior to maintenance action.

After placing a fire protection system back into service, notify the proper authorities and advise those responsible for alarm systems and monitoring.

NOTE: The property owner or designated representative should take care to prevent damage to equipment or the structure during the test. Damage could be caused by the system discharge or by runoff from the test site. It should be verified that there is adequate and unobstructed drainage. Water damageable equipment should be removed or covered as necessary to prevent damage.

Preventive Maintenance

The frequency of inspection should be determined according to the quality of the firewater in use, even so it is recommended that the strainers basket screen be dismantled and cleaned at least annually in addition to after each operation or system flow test.

Warning: The basket screen shall be cleaned when pressure drop exceeds the max allowable pressure differential of 7 psi (0.5 bar) across the strainer screen, determined at maximum flow rate.

Maintenance Procedure

Verify that the strainer is depressurized and drained before the disassembly of any strainer component.

The strainer basket screen should be cleaned after each system operation or flow test and during routine inspections, as follows:

1. The system must be shut down and completely drained.
2. Remove the strainer cover and the basket screen.
3. Clean out the basket screen, as well as the interior of the strainer body.
4. Reinstall the basket screen, make sure that the basket is fully inserted into the strainer body and is correctly orientated.
5. Inspect the gasket o-ring and replace if needed.
6. Reinstall the strainer cover, gradually cross tighten diametrically and sequentially all bolts so as to apply uniform load for the cover seal.



(for Illustration Only)

BERMAD Fire Protection

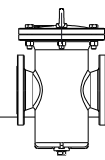

Model FP-60F

Strainers

Technical Data

- Available sizes:** 3, 4, 6, 8, 10, 12, 14, 16, 18, 20 and 24"
- UL-Listed sizes:** 3, 4, 6, 8, 10 and 12"
- End connections standard:** ANSI B16.42 #150RF
- Design pressure / Pressure rating:** 300 psi (20.7 bar)
- UL-Listed pressure:** 200 psi (13.8 bar)
- Pressure drop:** 3 psi at 15 ft/sec (0.2 bar at 4.57 m/sec) approx, see note 3
- Max allowable differential pressure:** 7 psi / 0.5 bar, refer to notes 3 and 4
- Screen hole diameter:** 1/8 inch (3.2 mm) holes diameter
- Basket screen area to pipe cross-sectional area ratio:** 10:1 (min)
- Basket screen free flow area ratio:** 40% (min)
- Drain/Blow-Off port:** size 3 - 12" bottom plug, 14 - 24" side plug
- Temperature rating:** 90°C / 194°F

Standard Material of Construction

Item	Description	Material
1	Body	Ductile Iron ASTM A536 65-45-12, Coated*
2	Cover	Ductile Iron ASTM A536 65-45-12, Coated*
3	Gasket	EPDM, Asbestos Free
4	Bolting	Stainless steel 304
5	Screen	Stainless steel 316
6	Lifting Eye	Stainless steel 304
7	Drain Plug	Stainless steel 316
8	Name Plate	Stainless steel 304

* Coating: Fusion Bonded High Build Epoxy RAL 3002, internally and externally

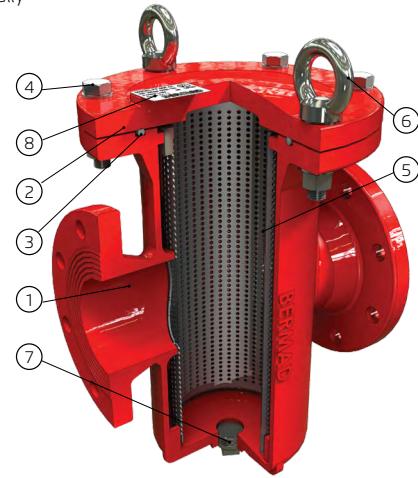
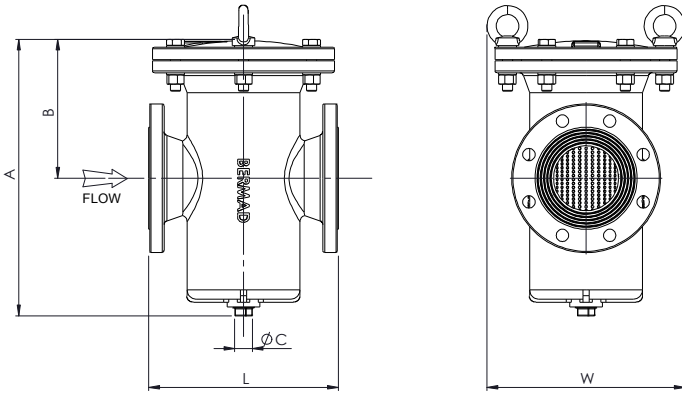

(for Illustration Only)

Flow Properties

Size	3"		4"		6"		8"		10"		12"		14"		16"		18"		20"		24"	
Units	metric	US	metric	US	metric	US	metric	US	metric	US	metric	US	metric	US	metric	US	metric	US	metric	US	metric	US
Kv ⁽¹⁾ / Cv ⁽¹⁾	185	213	295	344	650	750	1155	1334	1804	2084	2500	2920	3500	4085	4350	5076	5050	5893	6100	7119	8400	9803
Leq ⁽²⁾	8	26	13	42.5	21.5	70.5	28	92	37.5	123	45.5	149	-	-	-	-	-	-	-	-	-	-

- Notes:**
- ⁽¹⁾ Flow coefficient Kv: flow in m³/h at 1 bar differential pressure, Cv: flow in gpm at 1 psi differential pressure; The pressure loss calculation formula: $\Delta p = SG (Q / Cv \text{ or } Kv)^2$
 - ⁽²⁾ Leq: Equivalent pipe length for turbulent flow in clean commercial steel pipe (SCH 40)
 - ⁽³⁾ Clean Strainer friction loss: 3 psi at pipe flow velocity of 15 ft/sec (0.2 bar at 4.57 m/sec), applicable for 3 -12" size only
 - ⁽⁴⁾ Max allowable pressure drop: 7 psi (0.5 bar) across the strainer, basket screen shall be cleaned when pressure drop exceeds value determined at maximum flow

Dimensions and Weights

Size	3"		4"		6"		8"		10"		12"		14"		16"		18"		20"		24"	
DN	80		100		150		200		250		300		350		400		450		500		600	
Units	mm	in	mm	in	mm	in	mm	in	mm	in	mm	in	mm	in	mm	in	mm	in	mm	in	mm	in
L	250	9.8	292	11.5	378	14.9	476	18.7	560	22.0	680	26.8	770	30.3	800	31.5	842	33.1	842	33.1	1054	41.5
A	310	12.2	410	16.1	545	21.5	685	27.0	772	30.4	958	37.7	950	37.4	950	37.4	970	38.2	1110	1110	50.6	50.6
B	150	5.9	195	7.7	275	10.8	310	12.2	360	14.2	460	18.1	350	13.8	385	15.2	435	17.1	519	20.4	525	20.7
W	263	10.4	305	12.0	391	15.4	485	19.1	572	22.5	693	27.3	485	19.1	572	22.5	693	27.3	693	27.3	693	27.3
C	20	3/4"	24	1"	24	1"	40	1.5"	40	1.5"	50	2"	50	2"	50	2"	50	2"	50	2"	50	2"
D	3.2	0.13	3.2	0.13	3.2	0.13	3.2	0.13	3.2	0.13	3.2	0.13	6.4	0.25	3.2	0.13	3.2	0.13	3.2	0.13	3.2	0.13
Weight kg/lbs	23	51	42	93	72	159	130	287	190	419	285	628	470	1036	505	1113	645	1422	850	1874	1550	3417

Ordering Information

Orders include the description and Part Number. Please contact local BERMAD distributor for further data and availability.

Size in.	DN	BERMAD Product Code and Description	Hole Dia (mm)	Hole Dia (in)	Part Number
3"	80	FP-3"-60F-01-H-C-A5-ER, UL-Listed Basket Strainer, ANSI#150-RF	3.2	0.125	60F03HCA5N00001-ER
4"	100	FP-4"-60F-01-H-C-A5-ER, UL-Listed Basket Strainer, ANSI#150-RF	3.2	0.125	60F04HCA5N00001-ER
6"	150	FP-6"-60F-01-H-C-A5-ER, UL-Listed Basket Strainer, ANSI#150-RF	3.2	0.125	60F06HCA5N00001-ER
8"	200	FP-8"-60F-01-H-C-A5-ER, UL-Listed Basket Strainer, ANSI#150-RF	3.2	0.125	60F08HCA5N00001-ER
10"	250	FP-10"-60F-01-H-C-A5-ER, UL-Listed Basket Strainer, ANSI#150-RF	3.2	0.125	60F10HCA5N00001-ER
12"	300	FP-12"-60F-01-H-C-A5-ER, UL-Listed Basket Strainer, ANSI#150-RF	3.2	0.125	60F12HCA5N00001-ER



info@bermad.com • www.bermad.com

© Copyright 2007-2012 BERMAD CS Ltd. All Rights Reserved. The information contained in this document is subject to change without notice. BERMAD shall not be liable for any errors contained herein. Rev.1 April 2017