

Model: 400E-4M

Bermad Pneumatically Controlled (Dry Pilot) Deluge Valve with Easylock Manual Reset

Installation Operation Maintenance



 LISTED



Model: FP-400E-4M Size: 2"-12"

Safety First

BERMAD believes that the safety of personnel working with and around our equipment is the most important consideration. Please read all safety information below and from any other relevant source before attempting to perform any maintenance function.

Comply with all approved and established precautions for working with your type of equipment and/or environment.

Authorized personnel should perform all maintenance tasks.

Prior to performing a procedure, read it through to the end and understand it. If anything is not clear, ask the appropriate authority. When performing a procedure, follow the steps in succession without omission.

1. Description

The Bermad Pneumatically Controlled Deluge Valve is suitable for automatic water spray or foam systems that include pneumatic release dry pilot line with closed fusible plugs (thermal releases) and piping systems with open nozzles, It requires a pneumatic pressure supply system and compatible fusible plugs wet pilot line.

This Deluge Valve is equipped with an Easy Lock Manual Reset (M fig.1),(EMR) device, which locks it into an open position during activation. The controlled trim includes a PORV Pneumatic Actuator (6B fig.1), normally held closed by pressure maintained in the pneumatic release system, and a Manual Emergency Release (15B fig.1).

In Fire condition, in response to the opening of the pneumatic release, the pneumatic pressure drops, causing the PORV to open, releasing trapped water pressure from the control chamber and opening the Deluge Valve, allowing water to enter the system piping. Whenever either the Dry Pilot line or Manual Emergency Release (15B fig.1) is activated, the EMR locks the Deluge Valve in its open position. The Bermad Deluge Valve will close again only when the reset button on the EMR is pressed.

Deluge systems are commonly used where, in time of fire, it is necessary to simultaneously spray water from all open sprinklers and/or nozzles on the system.

2. Approvals

BERMAD 400E-4M Deluge Valve is UL Listed when installed with specific components & accessories. Refer to the current UL Directory. Consult the manufacturer for any component approval recently to appear in the UL fire protection equipment directory.

3. Installation

NOTES:

- Any deviation in trim size or arrangement may adversely affect the proper operation of the Deluge Valve.
- All initiating devices (detectors), indicating appliances, releasing devices, pilot line actuation devices (such as thermostatic releases, and/or fixed temperature releases), as well as the system control panel, must be compatible and UL listed for use with the particular Deluge System. Refer to current "UL Listed Fire Protection Equipment Directory". Refer also to NFPA 13 or the applicable installation standards, codes and authorities having jurisdiction.

WARNING: The Deluge Valve and trim must be installed only in areas where they will not be subjected to freezing temperatures.



Model: FP-400E-4M Size: 2"-12"

Installation Instructions

- 3.1. Allow enough room around the valve assembly for any adjustments and future maintenance/disassembly work.
- 3.2. Before the valve is installed, flush the pipeline to remove any dirt, scale, debris, etc. Not flushing the line may render the valve inoperable.
- 3.3. Install the valve in the pipeline with the valve flow arrow on the body casting in the proper direction. Ensure that the valve is positioned so that the cover/actuator can be easily removed for future maintenance.
- 3.4. Ensure that the EMR is Mounted Vertically (with the reset button up), and all other components are positioned correctly as per the appropriate drawing.
- 3.5. The water supply priming line must be connected to the upstream of the system control valve.
- 3.6. Subjected to all other instructions, drawings and technical specifications, which describe Bermad Deluge Valve, installed in their proper positions the components comprising the Deluge Trim Package, according to the drawing relevant to the specific type, hereby enclosed.
- 3.7. Install also the additional accessories, which appear in the drawing and which must be installed as shown in the drawing, although they are not packed together with the Bermad Deluge Valve itself.
- 3.8. Install pneumatic pressure supply system; see "Pneumatic System Pressure Requirements" below.



Model: FP-400E-4M Size: 2"-12"

System Components

- 1 - Main Valve, FP 400E Series
 - 2A - Gauge Valve
 - 3A - Pressure Gauge
 - 4B - Priming Strainer
 - 5A - Drain Valve
 - 6B - Pneumatic Pressure Operated Relief Valve (PORV)
 - 11A - Alarm Shutoff Valve
 - 14A - Check Valve
 - 15B - Manual Emergency Release
 - 18B - Priming Ball Valve
 - 19B - Drip Check
 - M - EasyLock Manual Reset
- Optional**
- P - Pressure Switch
 - W - Water Motor Assembly
 - S - Valve Position Limit Switch / Switches

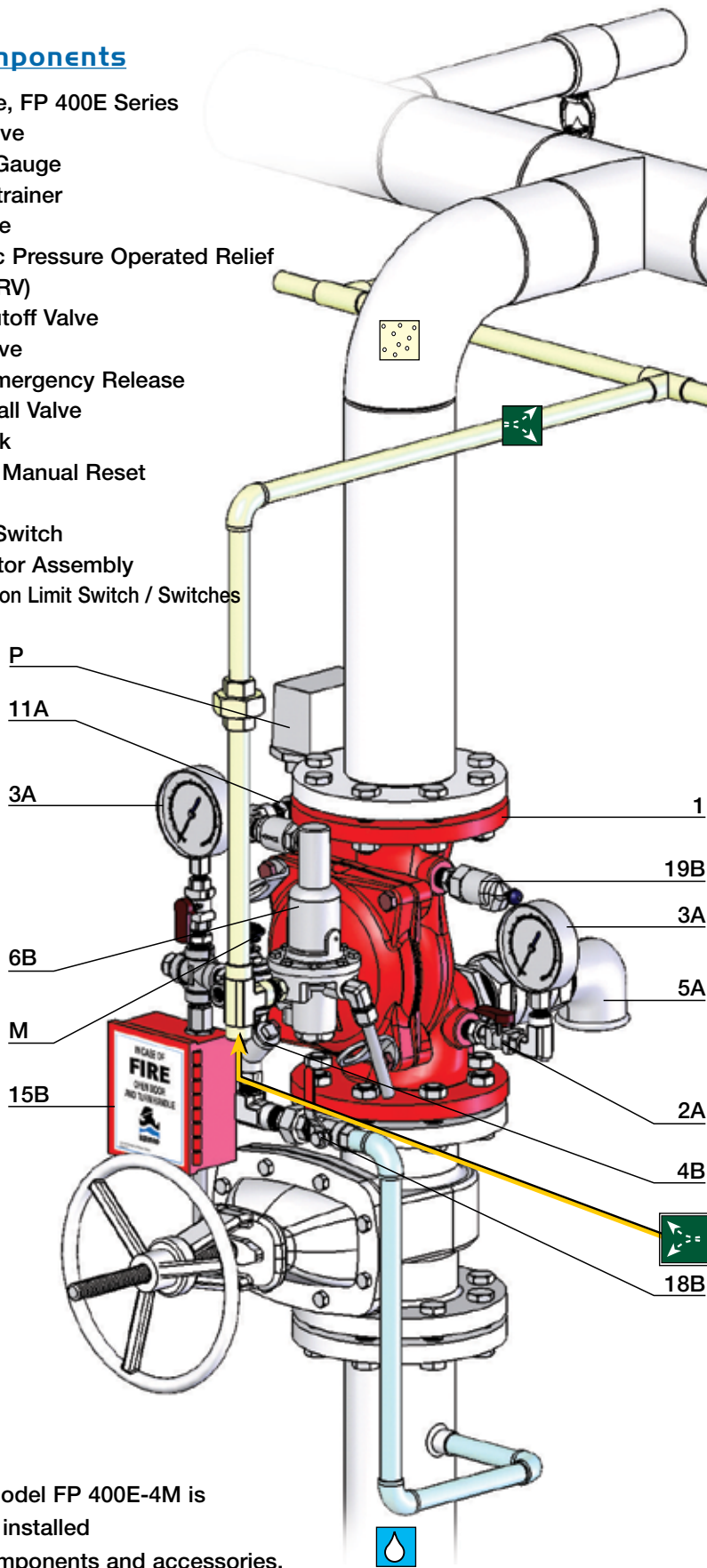

UL Listed

The BERMAD Model FP 400E-4M is UL-Listed when installed with specific components and accessories.



appliceng@bermad.com • www.bermad.com

The information contained in this document is subject to change without notice. BERMAD shall not be liable for any errors contained herein. All Rights Reserved. © Copyright by BERMAD Control Valves.

PI4PE14-400E-4M

4. Equivalent Length

Deluge Valve Equivalent Length Value (Steel Pipe), for use in hydraulically calculated systems

Valve Size	Equivalent Length Value Meter (Ft)
2"	9.1 (30) of 2" pipe
2½"	12.1 (40) of 2½" pipe
3"	13.7 (45) of 3" pipe
4"	14 (46) of 4" pipe
6"	27.4 (90) of 6" pipe
8"	45.7 (150) of 8" pipe

5. Optional Equipment

- 5.1. If required, provide an Alarm Pressure Switch (P fig.1), to either activate an electric alarm, or shut down desired equipment. Connect it according to manufacturer instructions.
- 5.2. If required, provide a Water Motor Alarm, it shall be assembled and Installed according to instructions within its package.
- 5.3. Provide for a suitable air compressor, nitrogen or an air maintenance device. See "Pneumatic System Pressure Requirements".
- 5.4. Low air pressure switch is optional; it may be utilized in the Dry pilot line entrée in order to supervise the maintained pneumatic pressure.

6. Placing in Service/Resetting the System

- 6.1. Operate pneumatic pressure supply system, allowing release system pressure to build up to a range of 20 to 30 psig (1.4 to 2.0 barg). Check the entire system for leaks.
- 6.2. Check the entire Dry Pilot line release system for leaks. Replace any fused plugs temperature-releases.
- 6.3. NOTE: Any automatic air or nitrogen pressure supply must feed the system through an orifice restriction. If a low air pressure alarm is utilized, test it by dropping the release line pressure. Restore pressure after the test.
- 6.4. Close all emergency release valves.
- 6.5. Open the priming-line valve (18B fig.1). Check that there is no water flow from the Solenoid Valve.
- 6.6. Push and hold the EMR's reset button, this allows upstream water pressure to fill the Deluge Valve's control chamber.
- 6.7. When the control chamber pressure gauge (3A fig.1) indicates full upstream pressure and is no longer rising, the release system is reset.
- 6.8. Slowly Open the supply Isolating Valve and check that no water flows into the system.
- 6.9. Depress the Drip Check (19B fig.1) and drain any water from the system side of the Deluge Valve.

The system is now operational and in a standby mode.

Ensure that the following Set Conditions are met.



Set Conditions (Normal Conditions)

Item	Status
All Main Isolating Valves	OPEN and sealed with tamperproof seals
All Manual Releases	CLOSE position and sealed
Alarm Shut-Off Valve (11A)	OPEN position
Priming Ball Valve (18B)	OPEN
Control-Chamber Gauge	OPEN gauge valve, the Pressure Gauge indicates rate of pressure in Control-Chamber
Upstream Pressure Gauge	OPEN gauge valve, the Pressure Gauge indicates the upstream supply pressure to the Deluge Valve
Drip-Check Device (19B)	VENTED: Push the knob to confirm that there is no leakage.
Control Panel & Detections	Are in service and in a stand-by position.
Pneumatic Release System	20 to 30 psig (1.4 to 2.0 barg) is maintained, pressure supply system is ON and functioning properly

7. Removing the System from Service

WARNING: Do not shutoff the pressure supply and Do not apply lower pressure than normal for maintenance without closing the Main Isolating Supply Valve first.

When taking the Deluge System out of service, a fire patrol should be established in the system area. If automatic fire-alarm signaling equipment is utilized, the proper authority should be notified that the system is being removed from service. The insuring body and owner representative should also be notified when the system is being taken out of service.

8. Removing Instructions

- 8.1. Shut off the main supply-isolating valve.
- 8.2. Close the Priming line valve (18B fig.1) to Deluge Valve Control chamber.
- 8.3. Open all drain valves.
- 8.4. Release the water pressure from the control chamber of the Deluge Valve by pulling the Manual emergency release (15B fig.1).
- 8.5. If auxiliary power is used, disconnect the power supply and batteries.
- 8.6. Place "Fire Protection System out of Service" signs in the area protected by the system.



9. Operation

In the SET position, the line-pressure supplied to the main valve's control chamber via the priming line and through an Easy Lock Manual Reset device (EMR), is trapped by the EMR's internal check valve, by the PORV Pneumatic Actuator (6B fig.1) held closed, and by a closed Manual Emergency Release (15B fig.1). The trapped pressure holds the main valve's diaphragm and plug against the valve seat, sealing it drip-tight and keeping the system piping dry. The PORV is held closed by the pneumatic pressure maintained in the dry-pilot line.

In FIRE or TEST conditions, a pilot-line pneumatic pressure drop and opens the PORV. Trapped pressure is then released from the main valve's control chamber through the opened PORV or Manual Emergency Release. The EMR prevents line-pressure from entering the control chamber, allowing the main valve to latch open and water to flow into the system piping and to the alarm device.

WARNING: Whenever the handle of the Emergency Manual Release (15B fig.1) is pulled, the Deluge Valve opens, and water flows into the system's piping and to the alarm devices, the Deluge Valve will closed again only when the handle is returned to its original position and the reset button on the EMR is manually pressed.

9.1. Pneumatic System Pressure Requirements

A regulated supply of pressurized air or nitrogen is required to maintain a pneumatic pressure supply system, See "Placing in Service" section above prior to connecting an air supply to the system.

The Pneumatic system shall use a clean, dependable and continuous (24 hours a day, 7 days a week) compressed-air source using an independent air compressor or an Air Maintenance Device supplied by a dry nitrogen-gas supply or external high Air pressure source.

NOTE: Any event of an air supply failure, slow leakage of air from the pneumatic system, will result in activation of the PORV, causing the Deluge Valve to open. Water will then flow from any open sprinklers and/or spray nozzles on the system and the Alarm will operate.

9.2. Air Supply Troubles

Any event of an air supply failure, slow leakage of air from the pneumatic release system, and/or failure to restore air supply to the pneumatic release system, will result in activation of the Pneumatic PORV, causing the Deluge Valve to open. Similarly, if the release system is activated due to mechanical damage or malfunction, the Deluge Valve will open and water to flow into the system piping and to the alarm device.



Model: FP-400E-4M Size: 2"-12"

Figure 2: Operation Drawing

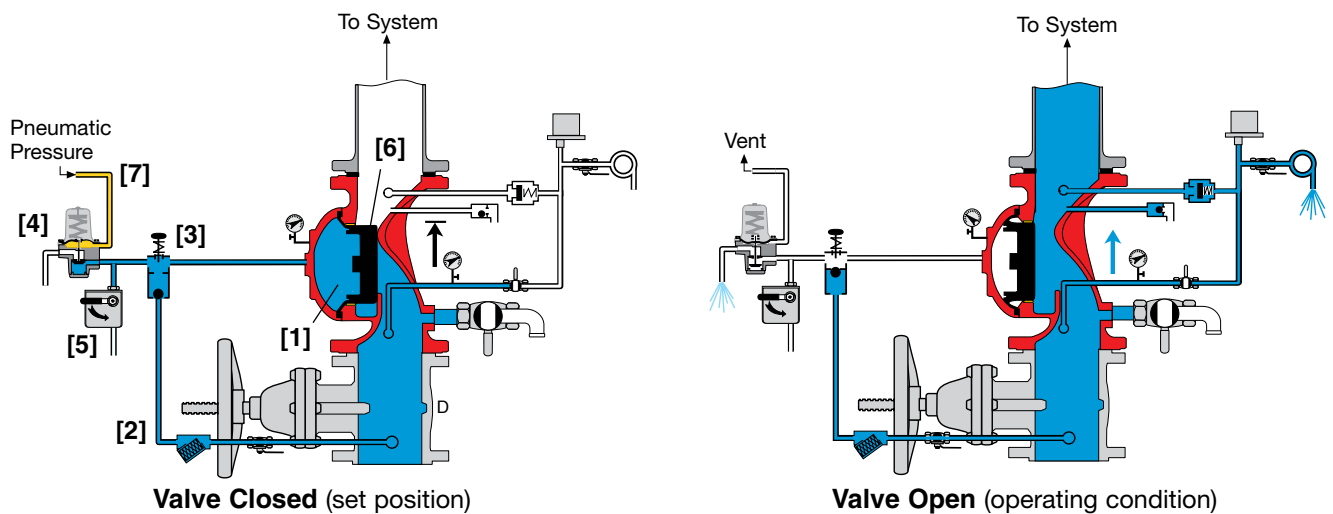

10. Maintenance and Inspection Test

WARNINGS:

- Do not shutoff the pressure supply and Do not apply lower pressure than normal for maintenance without closing the Main Isolating Supply Valve first.
- Do not turn off the water supply to make repairs without placing a roving fire patrol in the area covered by the system. The patrol should continue until the system is back in service.

10.1. Prior to turning off any valves or activating any alarms, notify local security guards and the central alarm station, if used, so that a false alarm will not be signaled.

10.2. In any of the following inspections or testing procedures, if an abnormal condition exists, see Abnormal Conditions for possible cause and corrective action.

10.3. See NFPA Pamphlet No. 25 and also relevant publications by authorities having jurisdiction.

11. Weekly Inspection

11.1. The system should be checked for Set Condition. See above "Set Condition (Normal condition)".

11.2. Observe the upstream pressure gauge (3A fig.1) : it should indicate that the normal supply of water pressure to the Deluge Valve is maintained.

12. Monthly Inspection and Test

12.1. Complete Weekly Inspection.

12.2. Test the water-motor alarm and/or electric alarm, by turning the alarm test valve (1A) to the open position. The alarm should sound. Turn to close position.

12.3. Depress the Drip Check (19B fig.1) to release accumulated water and to check main valve leakage (Significant water accumulation on the system side may indicate a sealing problem).

13. Semi-Annual Inspection

13.1. Complete Weekly and Monthly Inspection and Test.

13.2. Inspect the Pneumatic release system, Drain condensation from release-lines and service the dehydrator if necessary.



14. Annual Inspection and Test

- 14.1. Complete Weekly, Monthly and Semi-Annual inspections.
- 14.2. Place the system out of service (See "Removing the System from Service" above).
- 14.3. Trip the release-line system.
- 14.4. The interior of the Deluge Valve should be cleaned and inspected.
- 14.5. The interior of the PORV (6B fig.1), including its diaphragm and seal, should be inspected and cleaned
- 14.6. Place the system back in service. (See instructions «Placing the System in Service»).
- 14.7. The Deluge Valve must be activated at full flow.
- 14.8. **NOTE:** The system will be flooded! Take all necessary precautions to drain water and prevent damage in the area protected by the system.
- 14.9. Trip test the deluge system by decreasing pressure in the pneumatic release system.
- 14.10. The manual emergency release handle (15B fig1) is to be pulled. The Deluge Valve should open and discharge water. Observe upstream Pressure Gauge while full flow is on. Inspect all system nozzles.
- 14.11. Take all additional measures as required by NFPA-25 "Standard for the Inspection Testing and Maintenance of Water-Based Fire Protection Systems."
- 14.12. Clean the priming strainer (4B fig.1) prior to resetting the Deluge Valve.



15. Abnormal Conditions

15.1. Alarm Pressure Switch Fails to Sound

- A. Check for obstructions in the alarm test line.
- B. Clean the alarm-line strainer (if a water motor alarm is installed).
- C. Make certain the alarm is free to operate.
- D. Test the electrical circuit to the electric alarm (if utilized).

15.2. False Trip

Check and test the electrical circuit to the Solenoid Valve (14B fig.1)

- A. Check for Malfunctioning EMR device.
- B. PORV (6B fig.1) out of order

15.3. Leakage through Deluge Valve

Check for any of the following possible causes:

- A. Check for clogged priming strainer (4B fig.1).
- B. Inadequate Pneumatic Pressure supply.
- C. Leaking control trim
- D. Leaking Dry Pilot release system.
- E. Damaged deluge valve internal elastomer or seat

15.4. Deluge Valve Will Not Reset

Check for any of the following possible causes:

- A. The EMR Device is clogged or not reset properly
- B. Inadequate Pneumatic Pressure supply.
- C. Check for clogged priming strainer (4B fig.1), the screen should be properly cleaned.
- D. Closed priming valve (18B fig.1).
- E. Check for Foreign object lodged between seal and valve seat.
- F. Control Panel is not reset. Check for Faulty circuits, using manufacturer instructions.
- G. Leak in Dry Pilot Line release system.

15.5. Difficulty in Performance

Where difficulty in performance is experienced, the manufacturer or his authorized representative should be contacted if any field adjustment is to be made.

