



## Dry-Pipe Control Valve

### Model FP 400Y-DP

The BERMAD model 400Y-DP utilizes an elastomeric deluge valve, designed specifically for advanced fire protection systems and the latest industry standards. Dry-pipe systems include automatic sprinklers attached to pressurized dry sprinkler piping with supplementary electric monitoring and a Supervised Pneumatic system installed in the same area. The 400Y-DP admits water into the sprinkler system piping when there is a drop in pressure in the piping due to the opening of one or more fusible head sprinklers. As an option the 400Y-DP features a rotating valve position indicator available with limit switches for remote valve position monitoring.



(for illustration only)

### Benefits and Features

- **Safety and reliability**
  - Includes a low pressure accelerator as standard
  - 13 psi, low pressure relay pilot valve
  - Single piece, rugged elastomeric diaphragm - VRSD technology
  - Obstacle-free, uninterrupted flow path
  - No mechanical moving parts
  - Valve position limit switches (optional)
  - Local rotating valve position indicator beacon (optional)
- **High performance**
  - Straight through flow Y- type body
  - Approved up to PN25 / 365 psi
- **Quick and easy maintenance**
  - In-line serviceable
  - Quick and easy cover removal
  - Swivel mounted drain valves \*

\* Available for 3" through to 10" valves

### Typical Applications

- Sprinkler systems in freezing conditions
- Water Sensitive Storage
- Unheated Warehouses

### Approvals



UL-Listed  
Special System Water Control Valves  
Sizes 3" - 10"



FM Approved  
for Preaction and Refrigerated  
Area Sprinkler Systems  
Sizes 1½" - 8"



Det Norske Veritas  
Type Approval



ABS  
American Bureau of Shipping  
Type Approval



Lloyd's Register  
Type Approval

### Additional Features

- Valve position limit switches
- Rotating valve position indicator beacon
- Inlet and/or outlet drain valve/s
- Sea water compatibility
- Air maintenance device

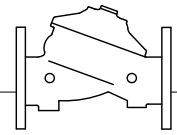

## Operation

(for illustration only)

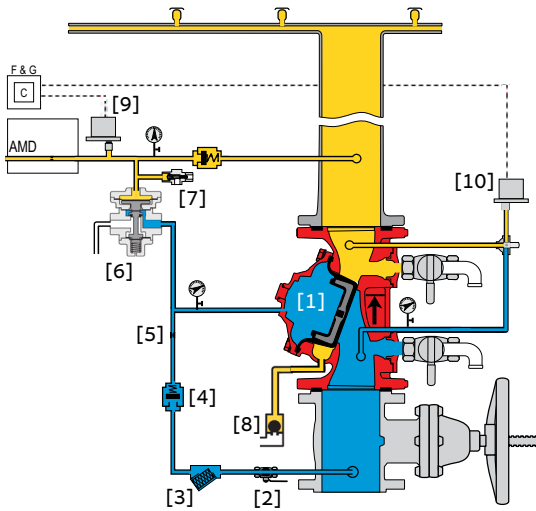

**Valve Closed** (normal conditions)

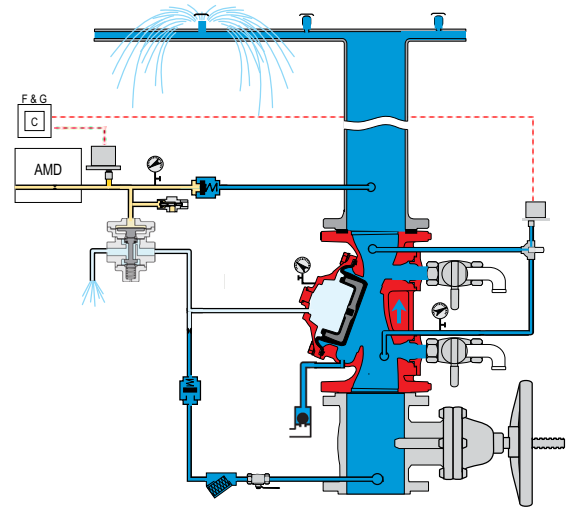

**Valve Open** (fire conditions)

The BERMAD model 400Y-DP is held closed by water pressure in the control chamber [1]. Upon release of pressure from the control chamber, the valve opens.

Under NORMAL conditions, water pressure is supplied to the control chamber via the priming line [2] strainer [3], restriction orifice [5] and is then trapped in the control chamber by a check valve [4] and a URV relay valve [6] which is held closed by the pneumatic pressure of the dry sprinkler pipeline. The dry pipe is kept dry by way of the auto drain device [8] which will expel any water that accumulates in the downstream. When the main valve opens the auto drain will automatically close.

In the event of fire the activation of the automatic sprinkler/s will cause a drop in pneumatic pressure, upon which the URV relay valve will open and the air pressure switch [9] will be activated. Water pressure will be released from the main valve control chamber, opening the main valve and admitting water into the piping and to the alarm device [10].

Once open the main valve will latch open by way of the now open low pressure accelerator valve [7], disabling any re-entry of water pressure into the main valve's control chamber. Closing the main valve can be done only manually and locally by resetting or reclosing the low pressure accelerator valve with the restored pipeline air pressure.

## System P&ID

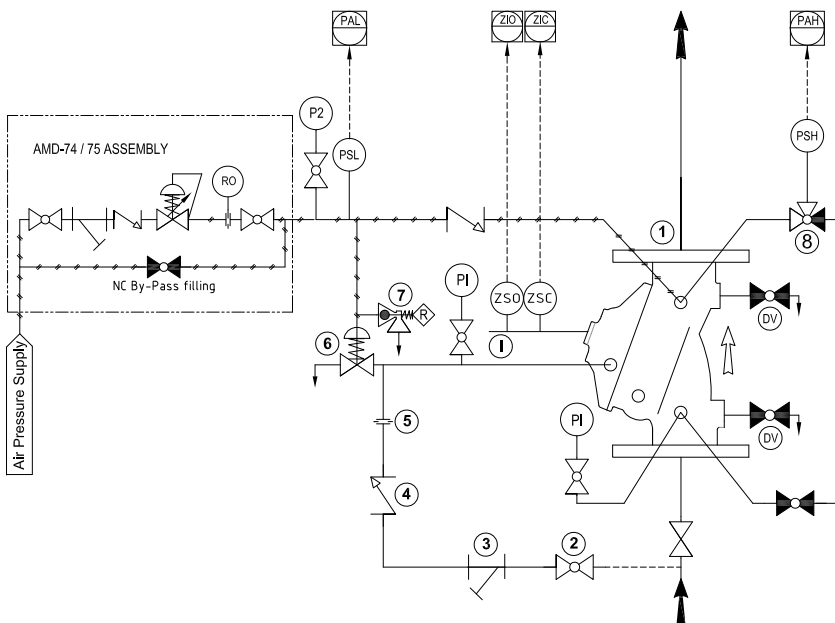

### Components

- 1 BERMAD 400Y Deluge Valve
- 2 Priming ball valve
- 3 Priming strainer
- 4 Check valve
- 5 Restriction orifice
- 6 URV relay pilot valve
- 7 Low pressure accelerator
- 8 3-Way alarm check valve
- PI Pressure gauge
- DV Drain valve

### Optional System Items

- ZS Limit switch assembly
- I Visual indicator
- PS Pressure Switch
- PSL Pressure switch (low)
- PSH Pressure switch (high)
- P2 Pressure gauge
- AMD Air maintenance device

See also Factory Fitted Options under the Valve Code Designations on the last page



## System Installation

A typical installation of the BERMAD model 400Y-DP features a pressurized dry sprinkler pipeline with a Supervised Pneumatic System installed in the same area. Deluge valve actuation is in response to the activation of one or more of the fusible sprinkler heads causing a drop in the dry sprinkler pipeline pressure, triggering the URV relay valve to open the 400Y-DP deluge valve. When fitted with a limit switch the main valve can send a feedback signal to a remote valve status monitoring system.

## Optional System Items

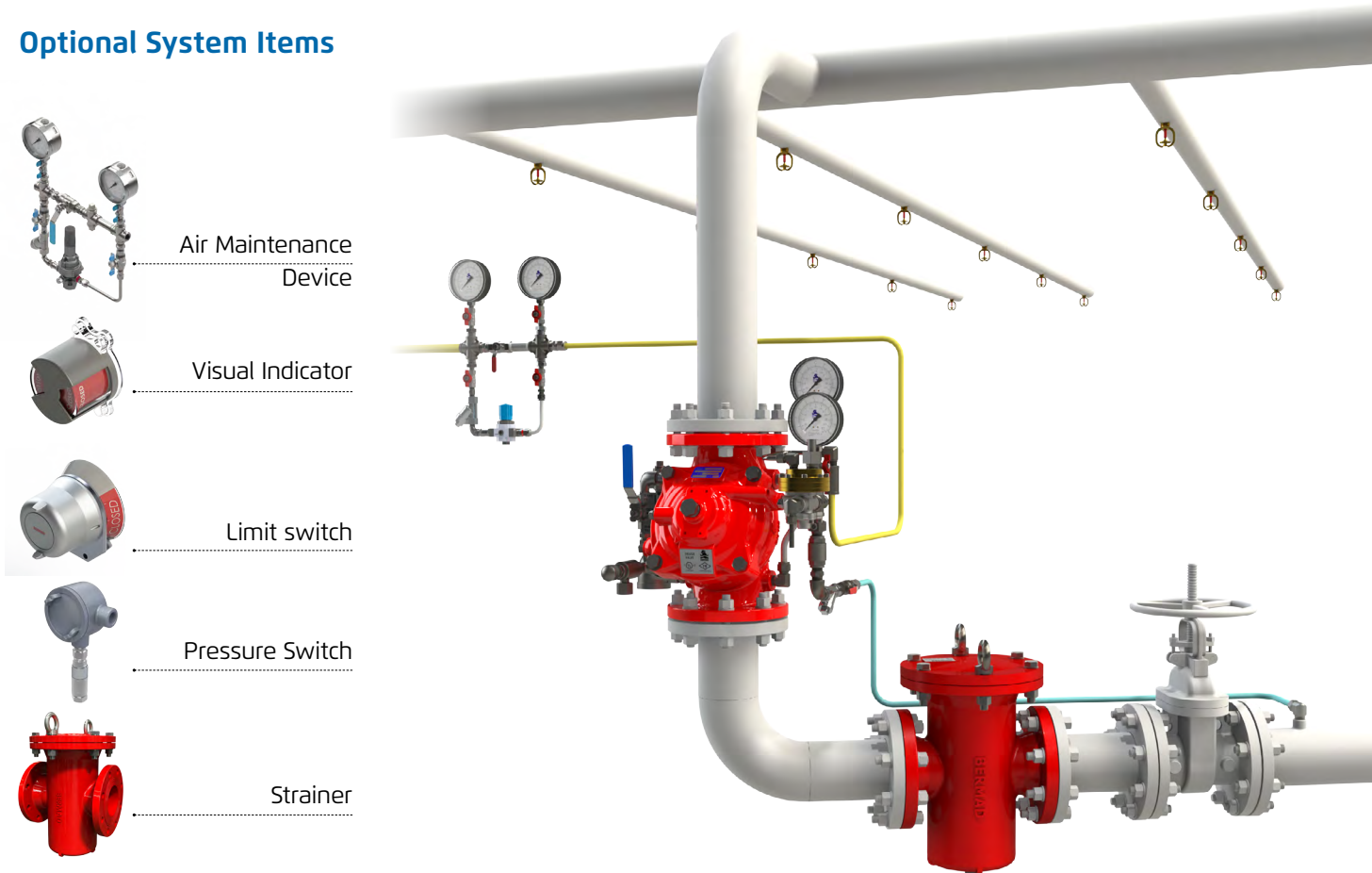

(for illustration only)

## Engineering Specifications

The Dry-Pipe valve shall be UL-listed and FM-approved for 25-bar / 365-psi, with a straight-through, Y-type-body. The Dry-Pipe valve shall have an unobstructed flow path, with no stem guide or supporting ribs. Valve actuation shall be accomplished by a single-piece, rolling diaphragm bonded with a rugged radial seal disk. The diaphragm assembly shall be the only moving part.

The Dry-Pipe valve shall include a 13 psi low pressure relay pilot valve with a low pressure accelerator device, a Y-type strainer, a ball drain valve, an automatic drip-check valve, 4-inch pressure gauges, and a manual emergency release housed in a stainless steel box. The valve drain socket shall be flanged and have 360-degree swivel.

The valve shall be equipped with a protective-covered, dual-color, rotational position indicator, readable from 50 meters, and with provision for a switch box.

Removing the valve cover for inspection or maintenance shall not require removing the control trim. The deluge valve and its entire control trim shall be supplied pre-assembled and hydraulically tested by a factory certified to ISO 9000 and 9001 standards.



## Technical Data

### Available Sizes (inch)

- Flanged - 1½, 2, 3, 4, 6, 8 & 10"
- Grooved - 1½, 2, 3, 4, 6 & 8"
- Threaded - 1½ & 2"

### Pressure Rating

- ANSI#150 - 16 bar / 235 psi
- ANSI#300 - 25 bar / 365 psi
- Grooved/Threaded - 25 bar / 365 psi

### Elastomer

- HTNR - Fabric Reinforced High Temperature Compound - See engineering data

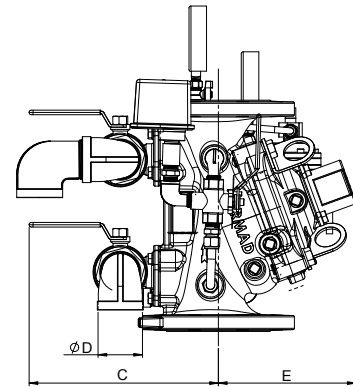
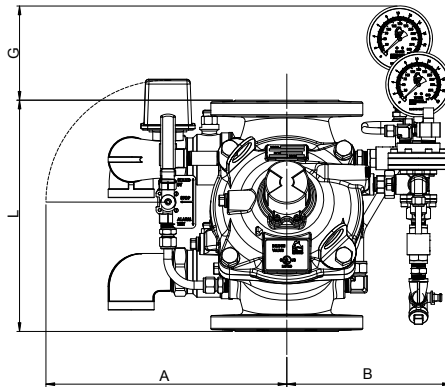

Valve Size	1½" DN40		2" DN50		3" DN80		4" DN100		6" DN150		8" DN200		10" DN250	
	mm	in	mm	in	mm	in	mm	in	mm	in	mm	in	mm	in
L <sup>(1)</sup>	230	9.1	230	9.1	310	12.2	350	13.8	480	18.9	600	23.6	730	28.7
L <sup>(2)</sup>	230	9.1	235	9.3	326	12.8	368	14.5	506	19.9	626	24.6	730	28.7
A	279	11.0	279	11.0	339	13.3	347	13.7	400	15.7	430	16.9	430	16.9
B	191	7.5	191	7.5	249	9.8	247	9.7	314	12.4	342	13.5	342	13.5
C	241	9.5	241	9.5	274	10.8	290	11.4	305	12.0	320	12.6	320	12.6
ØD	¾"		¾"		1½"		2"		2"		2"		2"	
E	120	120	146	158	228	295	295	441	441	415	120	120	146	158
G	101	4.0	101	4.0	91	3.6	78	3.1	30	1.2	-	-	-	-
Kv / Cv	68 / 79		80 / 92		190 / 219		345 / 398		790 / 912		1160 / 1340		1355 / 1565	
Leq <sup>(3)</sup> : m/ft	2 / 7		5 / 16		7 / 23		9 / 30		15 / 49		27 / 89		62 / 203	
Weight, flanged kg (lbs)	20 / 45		22 / 48		37 / 81		47 / 103		90 / 198		153 / 337		183 / 403	

- Notes: <sup>(1)</sup> Refers to the length dimensions for Raised Face ANSI #150, ISO 16 Flanged, Threaded and Grooved valves  
<sup>(2)</sup> Refers to the length dimensions for Raised Face ANSI #300 and ISO 25 Flanged valves  
<sup>(3)</sup> Leq (Equivalent Pipe Length) refers to turbulent flow in new steel pipe schedule 40, values given for general consideration only  
<sup>(4)</sup> Exact dimensions for the trim envelope may vary with specific component positioning

## Valve Code Designations

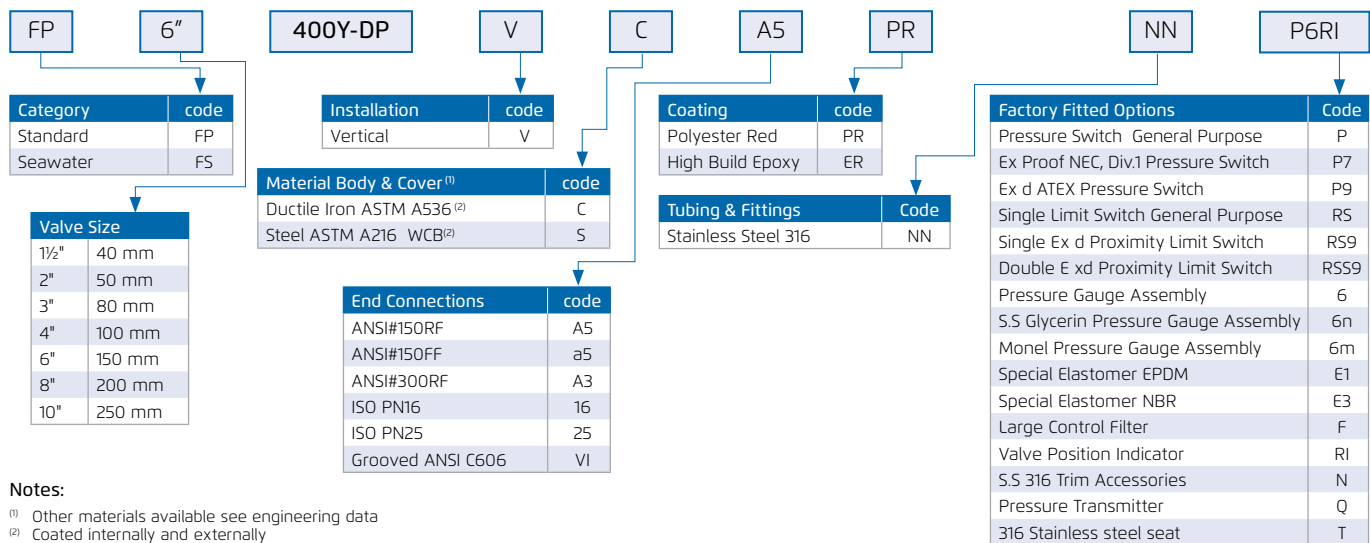

- Notes: <sup>(1)</sup> Other materials available see engineering data  
<sup>(2)</sup> Coated internally and externally

