

Booster Pump Control Valve

Quick Active Check Valve

WW-740Q

- Isolates system from the effects of pump starts and stops for:
 - Solitary single speed pumps
 - Battery of single speed pumps (add & switch)
 - Battery of variable speed pumps (add)

The Model 740Q Booster Pump Control Valve is a double chambered, hydraulically operated, diaphragm actuated active check valve that opens fully or shuts off in response to electric signals. It isolates the pump from the system during pump starting and stopping, to prevent pipeline surges.



Features and Benefits

- **Line pressure driven**
 - Independent operation
 - No motor required
 - Long term drip tight sealing
- **Solenoid controlled**
 - Low cost wiring
 - Wide ranges of pressures and voltages
 - Normally Open or Normally Closed
- **Check feature (spring loaded type)**
 - Replaces line sized check valve
 - Fail-safe mechanical closure
- **In-line serviceable** – Easy maintenance
- **Double chamber**
 - Full powered opening (option “B”) and closing
 - Non-slam opening and closing characteristic
 - Protected diaphragm
- **Balanced seal disk** – High flow capacity
- **Flexible design** – Easy addition of hydraulic features

Major Additional Features

- Pressure sustaining – **743**
- Pressure reducing – **742**
- Flow control – **747-U**
- Pump circulation control – **748**
- Deep well pump electric control – **745**
- Full powered opening & closing – **740-B**
- Electronic control – **740-18**
- Pressure sustaining & Pressure reducing – **743-2Q**

See relevant BERMAD publications.

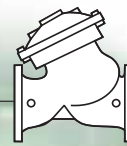

Sequence of Operation (Normally-Open Type)

The Model 740Q is a solenoid controlled valve equipped with a limit switch, a 3-Way solenoid pilot and check valves.

For large valves, an accelerator quickens valve response.

Pump Starting Procedure

Prior to pump start, the valve is hydraulically closed although electrically open. Even though the de-energized solenoid [1] vents the upper control chamber [2], it remains full as no opening hydraulic forces are applied. Pump start command is issued to the BR740-E electronic controller [3], which starts the pump. Valve upstream pressure builds and rises above the system static pressure, causing opening hydraulic forces to rise. Pressure is then released from the upper control chamber through the solenoid, allowing the valve to open gradually.

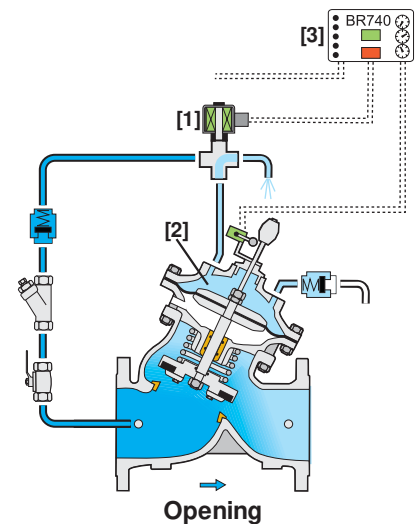

Pump Stopping Procedure

In pumping systems with standard check valves, the shut down command is issued directly to the pump, abruptly shutting it down. In systems with "active check valves", the shut down command is issued to the BR740-E electronic controller [3], which energizes the solenoid. The solenoid then applies pumped pressure to the upper control chamber, gradually closing the main valve, and isolating the running pump from the system. As the indicator collar [4] moves down, it activates the valve's limit switch [5], signaling the controller to shut down the pump. After a preset time delay, the controller de-energizes the solenoid and resets the limit switch command, allowing the pump to start when next signaled. The valve remains hydraulically closed and electrically open.

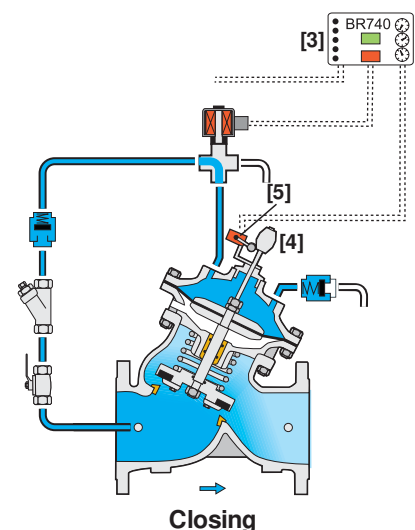

Power Failure – Spring Loaded, Zero Velocity Non-Return Valve

If electric power fails during pumping, the upstream pressure immediately drops causing the hydraulic forces acting on the diaphragm assembly [6] and closure [7], to balance. The spring [8] then breaks this balance, closing the valve before the flow can change direction. Check valve [9] allows air flow into the upper control chamber to brake possible vacuum and quicken the closing speed.

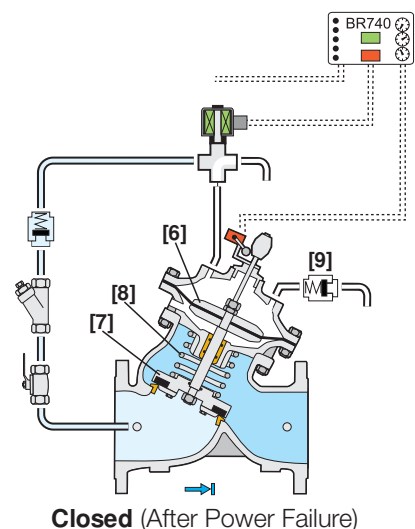

Note:
Valve configuration and control circuit might vary for PN 25 and/or large diameter valves.



Typical Installation

In this system, a pump battery supplies the main line through a manifold. The Model 740Q, installed downstream from each pump:

- Prevents surge generation rather than minimizing surge damage
- Provides surge free starting and stopping of supplementary pumps
- Allows surge free switching between “on-duty” pumps
- Delays reaction of variable speed primary pump to single speed supplementary pump going on line or off line.

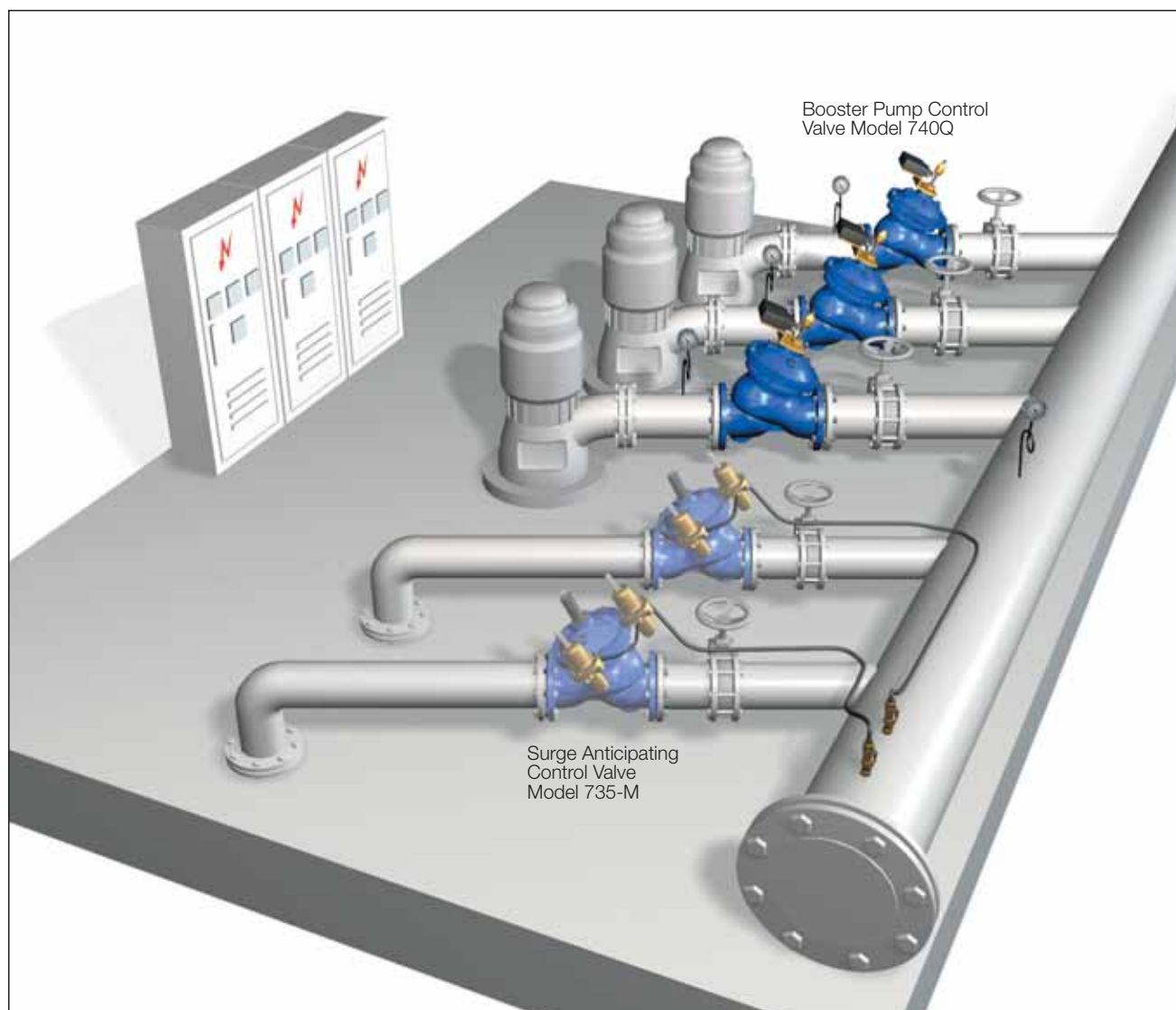

BR 740-E Electronic Controller

The BR 740-E coordinates between all system components to eliminate surges from the system. This controller provides built-in operating modes that can be selected on-site. These modes are based on accumulated know-how to prevent errors that might occur during on-site programming.



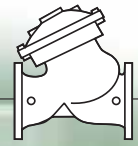

Sequence of Operation (Normally Closed Type)

The Model 740Q is a solenoid controlled valve equipped with a limit switch, a 3-Way solenoid pilot and check valves. For larger valves, an accelerator quickens valve response.

Pump Starting Procedure

Prior to pump start, the valve is closed hydraulically and electrically. The de-energized solenoid [1] together with the inlet check valve [2] and the airflow check valve [3], trap the pressure in the upper control chamber [4]. Pump start command is issued to the BR740-E electronic controller [5], which simultaneously starts the pump and energizes the solenoid. Valve upstream pressure builds and rises above the system static pressure, causing opening hydraulic forces to rise. The solenoid releases the pressure from the upper control chamber, allowing the main valve to open gradually.

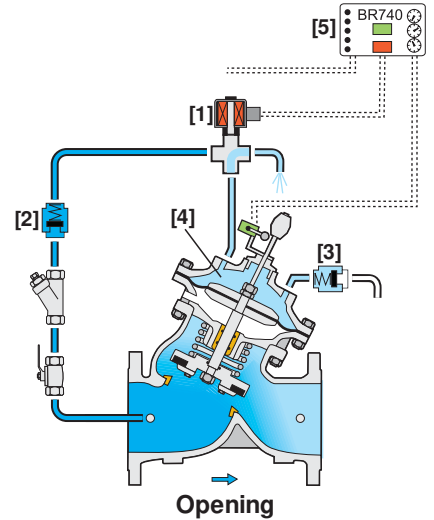

Pump Stopping Procedure

In pumping systems with standard check valves, the shut down command is issued directly to the pump, abruptly shutting it down. In systems with "active check valves", the shut down command is issued to the BR740-E electronic controller [5], which de-energizes the solenoid [1]. The solenoid then applies pumped pressure to the upper control chamber, gradually closing the main valve, and isolating the running pump from the system. As the indicator collar [6] moves down, it activates the valve's limit switch [7], signaling the controller to shut down the pump. The valve remains closed as the pumped pressure in the upper control chamber is trapped by the check valves and by the solenoid. After a preset time delay, the controller resets the limit switch command, allowing the pump to start when next signaled.

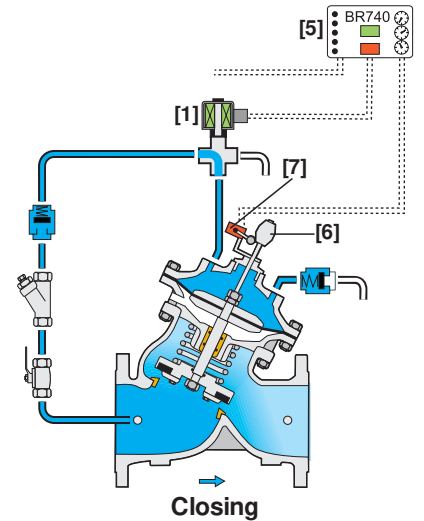

Power Failure – Spring Loaded, Zero Velocity Non Return Valve

If electric power fails during pumping, the upstream pressure immediately drops causing the hydraulic forces acting on the diaphragm assembly [8] and closure [9] to balance. The spring [10] then breaks this balance, closing the valve before the flow can change direction. Check valve [3] allows airflow into the upper control chamber to break possible vacuum and quicken the closing speed.

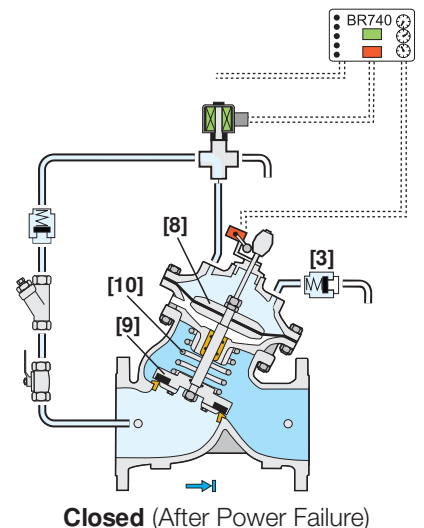

Note:
Valve configuration and control circuit might vary for PN 25 and/or large diameter valves

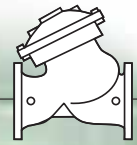

Additional Applications

Booster Pump Control & Pressure Sustaining Valve Model 743

Network demand is greater than pump design specifications:

- During empty pipeline filling
- During over demand by consumers
- When pump pressure specification is higher than system resistance

Any of these factors might cause pump overload & cavitation damage. The Model 743 adds a pressure sustaining feature to the Booster Pump Control Valve ensuring the pump operates within design specifications. This protects both the pump and the system while maintaining the operation sequence of the standard Model 740Q.

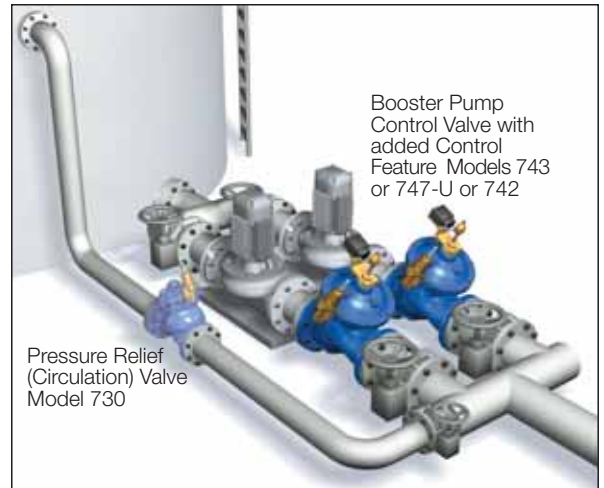

Booster Pump Control & Flow Control Valve Model 747-U

When the pump curve (Flow versus Pressure) is relatively flat pump protection with respect to discharge pressure is not sufficient, and protection according to flow is recommended.

The Model 747-U, adds a flow limiting feature to the operation sequence of the standard Model 740Q.

Booster Pump Control & Pressure Reducing Valve Model 742

Standard pumps are specified to boost pressure by a constant differential. Increased suction pressure causes excessive discharge pressure, which requires reduction. When the pump curve (Flow versus Pressure) is relatively steep, circulation of the excessive pressure is most suitable. However, when the pump curve is relatively flat, the additional circulated flow hardly affects the discharge pressure. The most suitable solution is to reduce the discharge pressure.

The Model 742, adds a pressure reducing feature to the operation sequence of the standard Model 740Q.

Engineer Specifications

The Pump Control Valve shall open fully or shut off in response to electric signals. It shall isolate the pump from the system during pump starting and stopping, to prevent pipeline surges.

Main Valve: The main valve shall be a center guided, diaphragm actuated globe valve of either oblique (Y) or angle pattern design. The body shall have a replaceable, raised, stainless steel seat ring. The valve shall have an unobstructed flow path, with no stem guides, bearings or supporting ribs. The body and cover shall be ductile iron. All external bolts, nuts, and studs shall be Duplex® coated. All valve components shall be accessible and serviceable without removing the valve from the pipeline.

Actuator: The actuator assembly shall be double chambered with an inherent separating partition between the lower surface of the diaphragm and the main valve. The entire actuator assembly (seal disk to top cover) shall be removable from the valve as an integral unit. The stainless steel valve shaft shall be center guided by a bearing in the separating partition. The replaceable radial seal disk shall include a resilient seal and shall be capable of accepting a V-Port Throttling Plug by bolting.

Control System: The control system shall consist of a 3-Way solenoid pilot (for 8" and larger valves, an accelerator shall be added to the solenoid), two check valves (for 12" and larger valves, an additional check valve), a limit switch, and a filter. All fittings shall be forged brass or stainless steel. The assembled valve shall be hydraulically tested.

Quality Assurance: The valve manufacturer shall be certified according to the ISO 9001 Quality Assurance Standard. The main valve shall be certified as a complete drinking water valve according to NSF, WRAS, and other recognized standards.

BERMAD Irrigation



WW-740Q

For full technical details, refer to Engineering Section.

WW-700 Series Pumping Stations

Technical Data

Dimensions and Weights

Size	A, B	C	L	H	Weight	
mm inch	mm inch	mm inch	mm inch	mm inch	kg lbs	
40	1 1/2"	350 14	180 7	205 8.1	239 9.4	9.1 20
50	2	350 14	180 7	210 8.3	244 9.6	10.6 23
65	2 1/2"	350 14	180 7	222 8.7	257 10.1	13 29
80	3"	370 15	230 9	250 9.8	305 12.0	22 49
100	4"	395 16	275 11	320 12.6	366 14.4	37 82
150	6"	430 17	385 15	415 16.3	492 19.4	75 165
200	8"	475 19	460 18	500 19.7	584 23.0	125 276
250	10"	520 21	580 23	605 23.8	724 28.5	217 478
300	12"	545 22	685 27	725 28.5	840 33.1	370 816
350	14"	545 22	685 27	733 28.9	866 34.1	381 840
400	16"	645 26	965 38	990 39.0	1108 43.6	846 1865
450	18"	645 26	965 38	1000 39.4	1127 44.4	945 2083
500	20"	645 26	965 38	1100 43.3	1167 45.9	962 2121

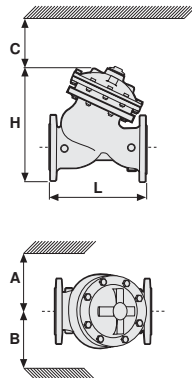

Data is for Y-pattern, flanged, PN16 valves
Weight is for PN16 basic valves
"C" enables removing the actuator in one unit
"L", ISO standard lengths available
For more dimensions and weights tables, refer to Engineering Section

Flow Chart

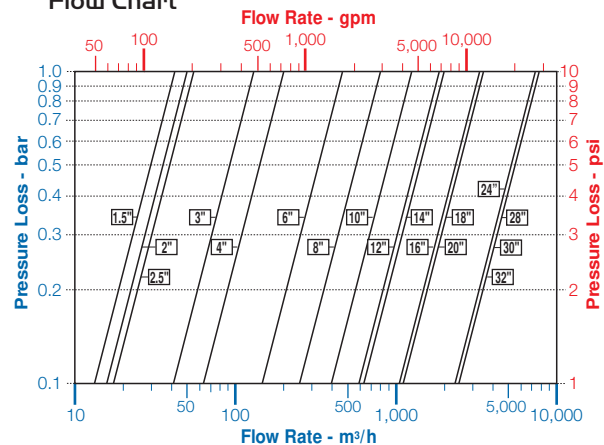

Data is for Y-pattern, flat disk valves
For more flow charts, refer to Engineering Section

Main Valve

Valve Patterns: "Y" (globe) & angle
Size Range: 1 1/2"-32" (40-800 mm)
End Connections (Pressure Ratings):
Flanged: ISO PN16, PN25 (ANSI Class 150, 300)
Threaded: BSP or NPT
Others: Available on request
Working Temperature:
Water up to 80°C (180°F)
Standard Materials:
Body & Actuator: Ductile Iron
Internals:
Stainless Steel, Bronze & coated Steel
Diaphragm:
NBR Nylon fabric-reinforced
Seals: NBR
Coating:
Fusion Bonded Epoxy, RAL 5005 (Blue)
NSF & WRAS approved or Electrostatic Polyester Powder, RAL 6017 (Green)

Control System

Standard Materials:
Accessories:
Bronze, Brass, Stainless Steel & NBR
Tubing: Copper or Stainless Steel
Fittings: Forged Brass or Stainless Steel
Solenoid Standard Materials:
Body: Brass or Stainless Steel
Elastomers: NBR or FPM
Enclosure: Molded epoxy
Solenoid Electrical Data:
Voltages:
(ac): 24, 110-120, 220-240, (50-60 Hz)
(dc): 12, 24, 110, 220
Power Consumption:
(ac): 30 VA, inrush; 15 VA (8W), holding or 70 VA, inrush; 40 VA (17.1W), holding
(dc): 8-11.6W
Values might vary according to specific solenoid model

Accelerator Standard Materials:
Body: Brass or Stainless Steel
Internals: Stainless Steel & Brass
Elastomers: NBR or FPM

Solenoid Selection

Valve Size	Solenoid Model		Accelerator Model	
	330 (2.0 mm)	311 (1.0 mm)	54	58HC
1 1/2"-8"	■			
1 1/2"-6"		■		
10-20"	■		■	
8-20"		■	■	
24-32"	■			■
24-32"		■		■

BR 740-E Controller
Supply voltage: 110, 230 V(ac) 50/60 Hz
Power consumption: <8 VA
Solenoid circuit fuse: 2A (Internal)
Pump control circuit fuse: 1A (Internal)
Dimensions: 96 x 96 x 166 mm (DIN), 0.75 kg
Housing material: NORYL (DIN 43700)
Limit Switch
Switch type: SPDT
Electrical rating: 10A, type gl or gG
Operating temperature: Up to 85°C (185°F)
Enclosure rating: IP66

How to Order

Please specify the requested valve in the following sequence: (for more options, refer to Ordering Guide)

Sector	Size	Primary Feature	Additional Feature	Pattern	Body Material	End Connections	Coating	Voltage & Position	Tubing & Fittings	Additional Attributes	
WW	6"	740Q	00	Y	C	16	EB	4AO	CB	S	
Waterworks	1 1/2" - 32"	Booster Pump Control		Oblique (up to 20") Angle (up to 18") Globe (24-32" only)	Ductile Iron Standard Cast Steel St. Steel 316 Nickel Alumin. Bronze	Epoxy FB Blue Polyester Green Polyester Blue Uncoated	EB PG PB UC	Copper Tubing & Brass Fittings Plastic Tubing & Brass Fittings St. St. 316 Tubing & Fittings	CB PB NN		
						24VAC/50Hz - N.C. 24VAC/50Hz - N.O. 24VDC - N.C. 24VDC - N.O. 24VDC - L.P. 220VAC/50-60Hz N.C. 220VAC/50-60Hz N.O.	4AC 4AO 4DC 4DO 4DP 2AC 2AO		Double Chamber Large Control Filter Electric Limit Switch Valve Position Transmitter Flow Over the Seat 3-way Control Loop St. St. 316 Control Accessories St. St. 316 Internal Trim (Closure & Seat) St. St. 316 Actuator Internal Assembly Delrin Bearing Viton Elastomers for Seals & Diaphragm Pressure Gauge	B F S Q O X N T D R E 6	

Multiple choices permitted

Multiple choices permitted



info@bermad.com • www.bermad.com

The information herein is subject to change without notice. BERMAD shall not be held liable for any errors. All rights reserved. © Copyright by BERMAD. P07AE40 05