

# Electro-Pneumatically Controlled On-Off Deluge Valve

## Model FP 400Y - 6D

The BERMAD Model 400Y-6D is an elastomeric, hydraulic line pressure operated deluge valve, designed specifically for advanced fire protection systems and the latest industry standards.

The 400Y-6D is suitable for systems that include electric or redundant (electric or pneumatic) fire detection systems. It opens in response to an electric signal and/or a drop in pressure of a pneumatic pilot line.

The optional valve position indicator can include a limit switch suitable for Fire & Gas monitoring systems.

The 400Y-6D is ideal for open-nozzle systems and is available with electrical components to suit any hazardous location.



(for Illustration Only)

### Benefits and Features

- **Safety and reliability**
  - Time-proven, simple, fail-safe actuation
  - Single-piece, rugged, elastomeric diaphragm seal – VRSD technology
  - Obstacle-free, uninterrupted flow path
  - No mechanical moving parts
  - Shuts off on remote command
  - Valve position limit switches (optional)
  - Local valve position indicator beacon (optional)
- **High performance**
  - Very high flow efficiency
  - Minimal head loss: straight-through Y-type body
  - Approved for PN25 / 365 psi
- **Designed for fire protection**
  - Face-to-face length standardized to ISO 5752, EN 558-1
  - Suitable for corrosive fluids: pneumatic solenoid valve
  - Meets the requirements of the industry standards
- **Quick and easy maintenance**
  - In-line serviceable
  - Fast and easy cover removal
  - Swivel mounted drain valves\*

\* not including 1½" & 2" valves

### Typical Applications

- Remote control water spray systems
- Foam applications
- Corrosive water systems
- Dual redundant detection systems

### Approvals



UL-Listed  
Special System Water Control  
Valves, Deluge Type (VLFT)  
Sizes 3" - 10"



Det Norske Veritas  
Type Approval



ABS  
American Bureau of Shipping  
Type Approval



Lloyd's Register  
Type Approval

### Additional Features

- Valve position limit switches
- Local valve position indicator beacon
- Alarm pressure switch
- Sea water compatibility
- Drain valve/s inlet/outlet
- Air Maintenance Device
- For "automatic activation" select BERMAD local or remote reset model

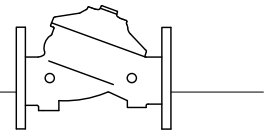

## Operation

(for Illustration Only)

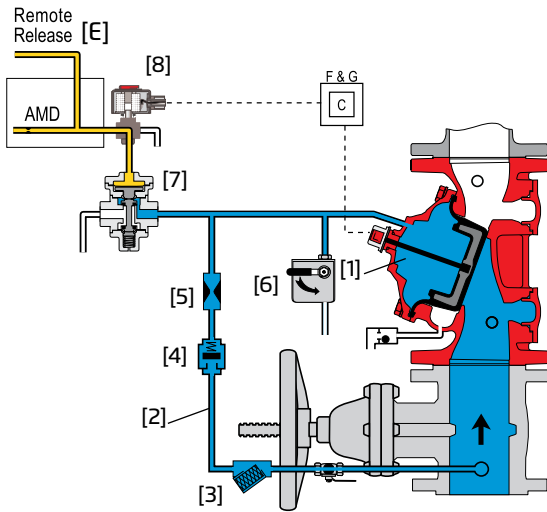

**Valve Closed** (normal conditions)

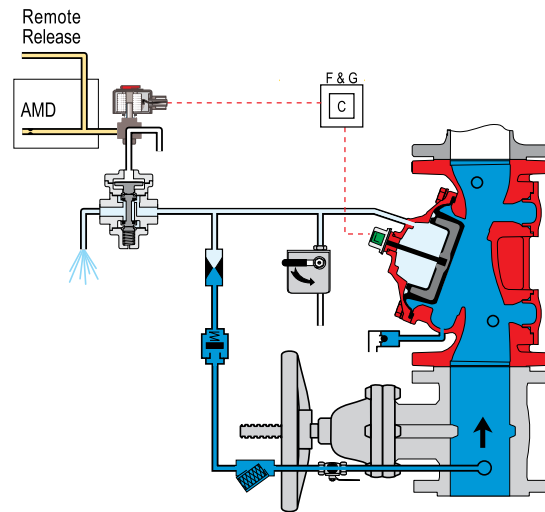

**Valve Open** (fire conditions)

The BERMAD model 400Y-6D is held closed by water pressure in the control chamber [1]. Upon release of pressure from the control chamber, the valve opens.

Under NORMAL conditions, water pressure is supplied to the control chamber via the priming line [2] strainer [3], and restricted orifice [5] it is then trapped in the control chamber by a check valve [4], manual emergency release [6], and a relay valve (URV) [7] that is held closed by pneumatic pressure supplied through a three-way solenoid valve [8].

The water pressure trapped in the main valve control chamber holds the diaphragm against the valve seat, sealing it drip-tight and keeping the system pipes dry.

Under FIRE conditions, water pressure is released from the control chamber, either with the manual emergency release, or by the URV opening. The URV opens in response either to a decrease in pneumatic pilot-line [E] pressure or to the solenoid valve being activated by the fire & gas control system [C]. This opens the 400Y-6D deluge valve, allowing water to flow into the system piping.

## System P&ID

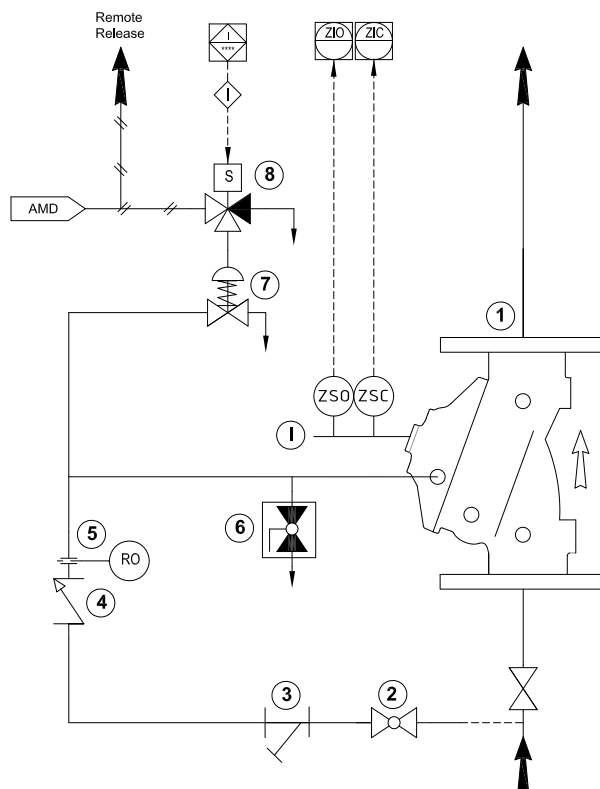

### Components

- 1 BERMAD 400Y Deluge Valve
- 2 Priming Ball Valve
- 3 Priming Strainer
- 4 Check Valve
- 5 Restriction Orifice
- 6 Manual Emergency Release
- 7 URV-2 Relay Valve
- 8 3-Way NC Solenoid Valve

### Optional System Items

- ZS Limit Switch Assembly
- I Visual Indicator
- AMD Air Maintenance Device

See also Factory Fitted Options under the Valve Code Designations on the last page





## System Installation

A typical installation of the BERMAD model 400Y-6D features actuation via a pneumatic universal relay valve. The valve can also be triggered electrically by a signal from a fire & gas control system or an on-site emergency pushbutton. When open and fitted with a limit switch the valve can send a feedback signal to a remote valve status monitoring system.

## Optional System Items

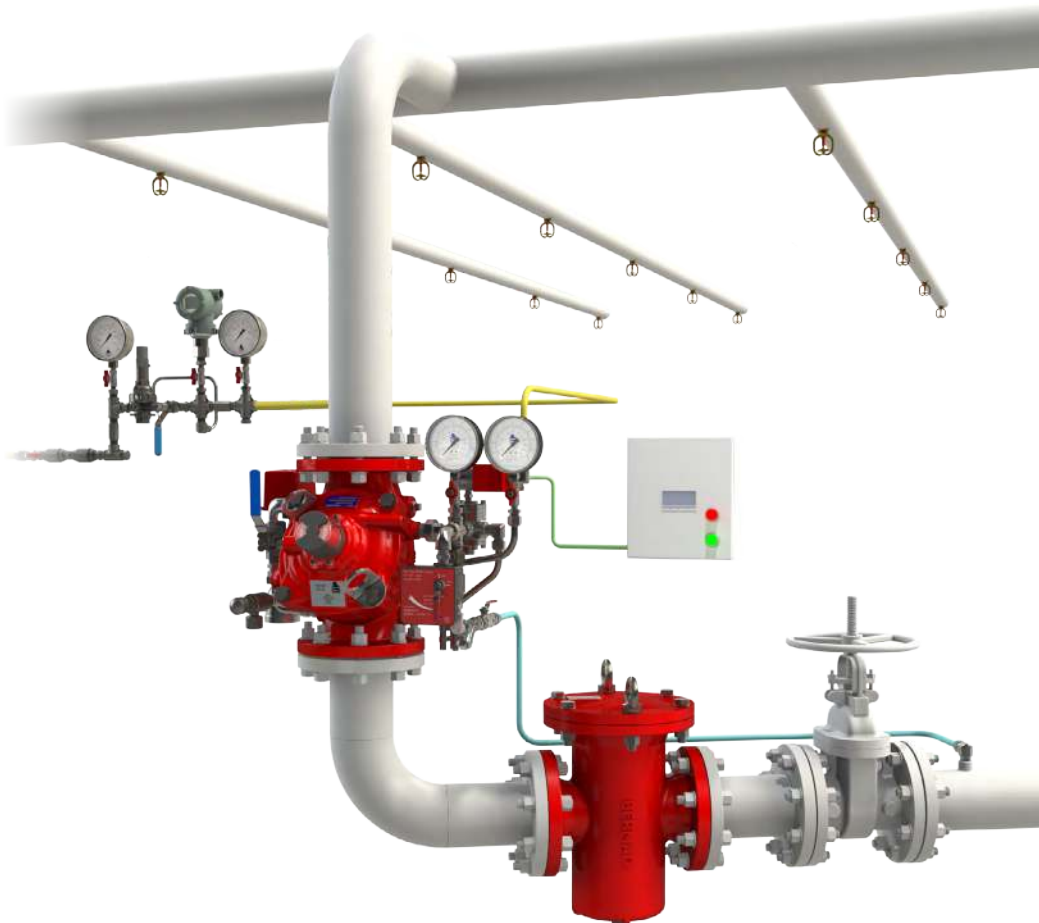
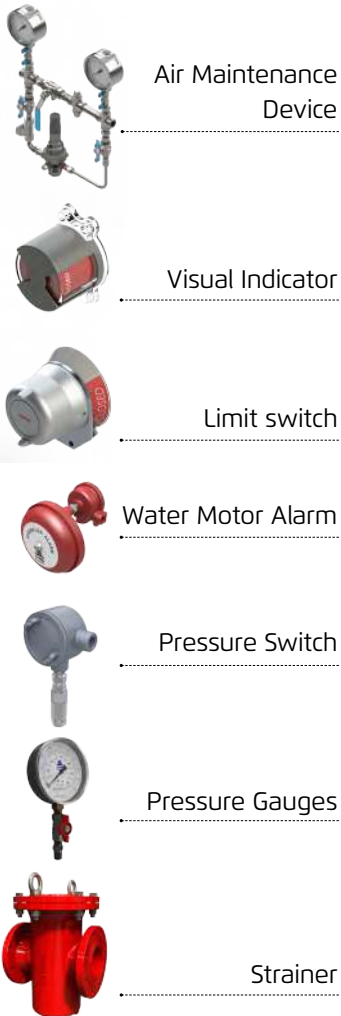

(for Illustration Only)

## Suggested Specifications

The deluge valve shall be UL-listed, 25 bar / 365 psi rated, elastomeric type with a straight-through, Y-type-body. The valve shall have an unobstructed flow path, with no stem guide or supporting ribs.

Valve actuation shall be accomplished by a single-piece, rolling diaphragm bonded with a rugged radial seal disk. The diaphragm assembly shall be the only moving part. The deluge valve shall include a relay pilot valve, a 3-way solenoid valve with a 35% tolerance below the rated voltage, a Y-type strainer, a ball drain valve, an automatic drip-check with manual override, 4-inch pressure gauges, and a manual emergency release housed in a stainless steel box. The valve drain socket shall be flanged and have 360 degree swivel.

The valve shall be equipped with a protective-covered, dual-color, rotational position indicator, readable from 50 meters, and with two limit switches enclosed in a protective switch box.

Removing the valve cover shall be in-line and not require removal of the control trim.

The deluge valve and its entire control trim shall be supplied pre-assembled and hydraulically tested by a factory certified to ISO 9000 and 9001 standards.

# BERMAD Fire Protection

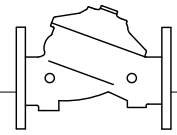

Model FP 400Y - 6D

400Y Series

## Technical Data

### Available Sizes (inch)

- Flanged - 1½, 2, 3, 4, 6, 8, 10, 12, 14 & 16"
- Grooved - 1½, 2, 3, 4, 6 & 8"
- Threaded - 1½ & 2"

### Pressure Rating

- ANSI#150 - 16 bar / 235 psi
- ANSI#300 - 1½" to 10" 25 bar / 365 psi  
12" to 16" 20 bar / 300 psi
- Grooved - 25 bar / 365 psi
- Threaded - 25 bar / 365 psi

### Elastomer

- HTNR - Fabric Reinforced High Temperature Compound - See engineering data

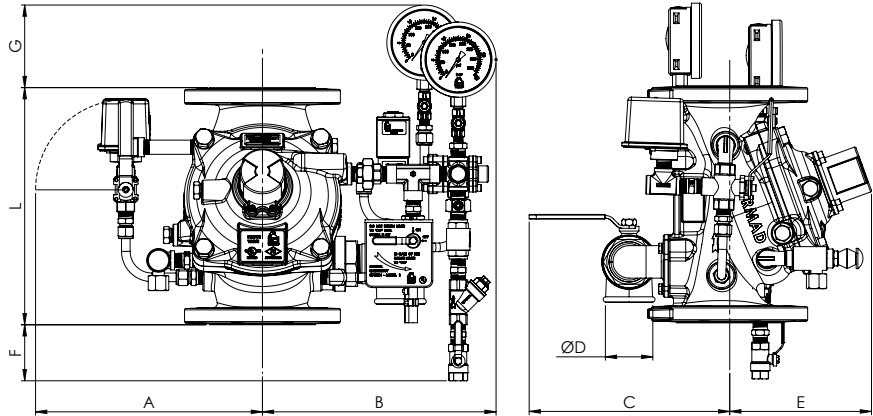

| Valve Size                           | 1½" DN40   | 2" DN50    | 3" DN80    | 4" DN100   | 6" DN150    | 8" DN200   | 10" DN250  | 12" DN300  | 14" DN350  | 16" DN400   |
|--------------------------------------|------------|------------|------------|------------|-------------|------------|------------|------------|------------|-------------|
| <sup>(1)</sup> L' ANSI #150 mm (in.) | 230(9.06)  | 230(9.06)  | 310(12.21) | 350(13.79) | 480(18.91)  | 600(23.64) | 730(28.76) | 850(33.49) | 980(38.61) | 1100(43.34) |
| L' ANSI #300 mm (in.)                | 230(9.06)  | 238(9.37)  | 326(12.84) | 368(14.50) | 506(19.94)  | 626(24.66) | 730(28.76) | 888(34.97) | 980(38.61) | 1100(43.34) |
| A mm (in.)                           | 330(13.0)  | 330(13.0)  | 390(15.4)  | 398(15.7)  | 451(17.8)   | 481(18.9)  | 481(18.9)  | 594(23.4)  | 594(23.4)  | 594(23.4)   |
| B mm (in.)                           | 234(9.2)   | 234(9.2)   | 292(11.5)  | 302(11.9)  | 357(14)     | 385(15.1)  | 385(15.2)  | 498(19.6)  | 498(19.6)  | 498(19.6)   |
| C mm (in.)                           | 241(9.5)   | 241(9.5)   | 274(10.8)  | 290(11.4)  | 304(12.0)   | 320(12.6)  | 320(12.6)  | 383(15.1)  | 383(15.1)  | 408(16.1)   |
| ØD                                   | ¾"         | ¾"         | 1½"        | 2"         | 2"          | 2"         | 2"         | 2"         | 2"         | 2"          |
| E mm (in.)                           | 167(6.6)   | 167(6.6)   | 191(7.5)   | 205(8.1)   | 273(10.7)   | 338(13.3)  | 338(13.3)  | 490(19.3)  | 490(19.3)  | 465(18.3)   |
| F mm (in.)                           | 184(7.2)   | 184(7.2)   | 114(4.5)   | 87(3.4)    | 5.5(0.2)    | -          | -          | -          | -          | -           |
| G mm (in.)                           | 146(5.7)   | 146(5.7)   | 136(5.4)   | 123(4.8)   | 74.5(2.9)   | 50(2)      | -          | -          | -          | -           |
| Kv m <sup>3</sup> /h (Cv gpm)        | 68(79)     | 80(92)     | 190(219)   | 345(398)   | 790(912)    | 1160(1340) | 1355(1565) | 2370(2737) | 2850(3292) | 3254(3758)  |
| <sup>(2)</sup> Leq m (ft)            | 2(7)       | 5(16)      | 7(23)      | 9(30)      | 15(49)      | 27(89)     | 62(203)    | 52(171)    | 59(194)    | 88(289)     |
| Weight, flanged kg (lbs)             | 15.3(33.5) | 16.7(36.6) | 31.4(69)   | 41.4(91)   | 84.7(186.3) | 147(325)   | 177(391)   | 321(706)   | 354(778.4) | 400(880)    |

Notes: <sup>(1)</sup> L1 Dimensions are for grooved, threaded and raised face flanged valves

<sup>(2)</sup> Leq (Equivalent Pipe Length) refers to turbulent flow in new steel pipe schedule 40, values given for general consideration only

<sup>(3)</sup> Dimensions for the trim envelope may vary with specific component positioning

## Valve Code Designations

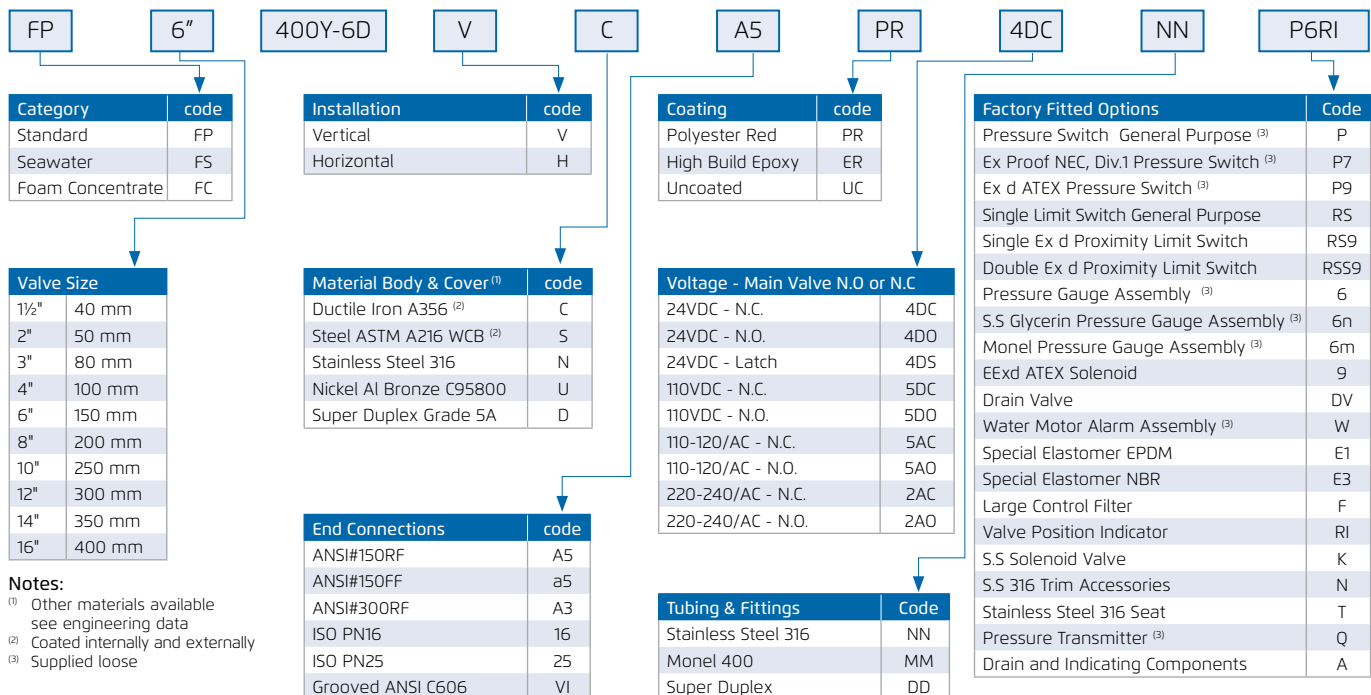

### Notes:

<sup>(1)</sup> Other materials available see engineering data

<sup>(2)</sup> Coated internally and externally

<sup>(3)</sup> Supplied loose



www.bermad.com

© Copyright 2007-2012 Bermad CS Ltd. All Rights Reserved. The information contained in this document is subject to change without notice. BERMAD shall not be liable for any errors contained herein. June 2017