

Hydraulically Controlled Deluge Valve with Local Reset

Model FP 400Y - 1M

The BERMAD model 400Y-1M is an elastomeric, hydraulic, line pressure operated deluge valve, designed specifically for advanced fire protection systems and the latest industry standards.

The 400Y-1M is activated by a pressure drop in a fusible plug wet pilot line. Once open the 400Y-1M latches open until locally reset.

The optional valve position indicator can include a limit switch suitable for Fire & Gas monitoring systems.

The 400Y-1M is ideal for systems with open nozzles for water or foam discharge.



(for Illustration Only)

Benefits and Features

- **Safety and reliability**
 - Time proven, simple, fail-safe actuation
 - Single piece, rugged elastomeric diaphragm seal - VRSD technology
 - Obstacle-free, uninterrupted flow path
 - No mechanical moving parts
 - Latches open until reset locally
 - Valve position limit switches (optional)
 - Local valve position indicator beacon (optional)
- **High performance**
 - Very high flow efficiency
 - Straight through flow Y- type body
 - Approved for PN25 / 365 psi
- **Designed for fire protection**
 - Face-to-face length standardized to ISO 5752 / EN558-1
 - Designed to meet the requirements of the industry standards
- **Quick and easy maintenance**
 - In-line serviceable
 - Fast and easy cover removal
 - Swivel mounted drain valves *

* not including 1½" & 2" valves

Typical Applications

- Hydraulic remote controlled systems
- Automatic water spray
- Foam applications
- Corrosive water systems

Approvals



UL-Listed
Special System Water Control
Valves, Deluge Type (VLFT)
Sizes 1½" - 16"



FM Approved
for Deluge Sprinkler Systems
Sizes 1½" - 8"



Det Norske Veritas
Type Approval



ABS
American Bureau of Shipping
Type Approval



Lloyd's Register
Type Approval

Additional Features

- Valve position limit switches
- Local valve position indicator beacon
- Sea water compatibility
- Drain valve/s inlet/outlet

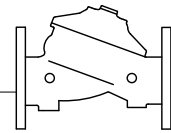

Operation

(for Illustration Only)

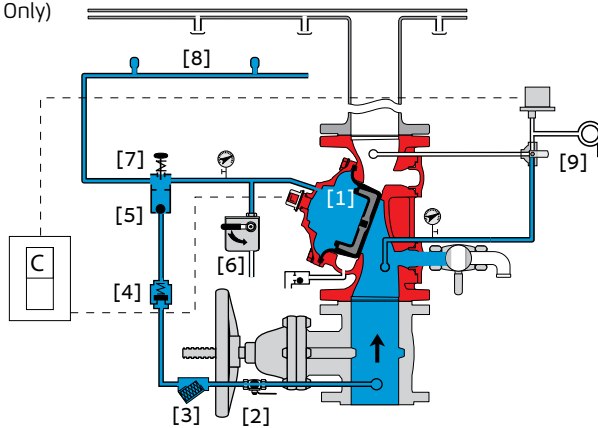

Valve Closed (normal conditions)

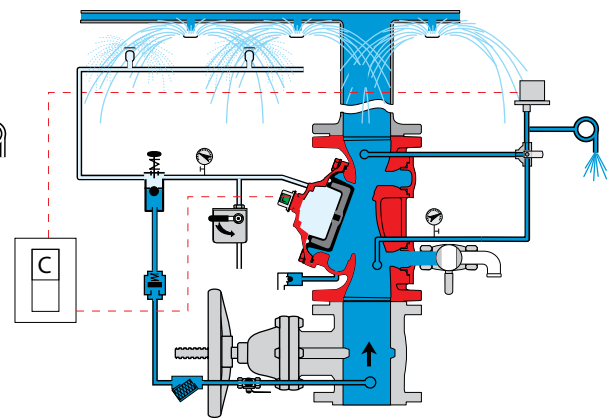

Valve Open (fire conditions)

The BERMAD model 400Y-1M is held closed by water pressure in the control chamber [1]. Upon release of pressure from the control chamber, the valve opens.

Under NORMAL conditions, water pressure is supplied to the control chamber via the priming line [2] and strainer [3], restriction orifice [5] and is then trapped in the control chamber by a check valve [4], manual emergency release [6] and the easy-lock manual reset valve [7]. The water pressure trapped in the control chamber of the deluge valve holds the diaphragm against the valve seat, sealing it drip-tight and keeping the system pipes dry.

Under FIRE conditions, water pressure is released from the control chamber, either with the manual emergency release, or by a release of water pressure of the hydraulic fusible plug pilot line [8], this increase in flow switches the easy-lock to close releasing pressure from the valve control chamber and thereby opening the deluge valve, allowing water to flow into the system piping and to the alarm device [9]. Once open the 400Y-1M latches open and can only be closed locally by manually depressing the easy-lock reset button.

System P&ID

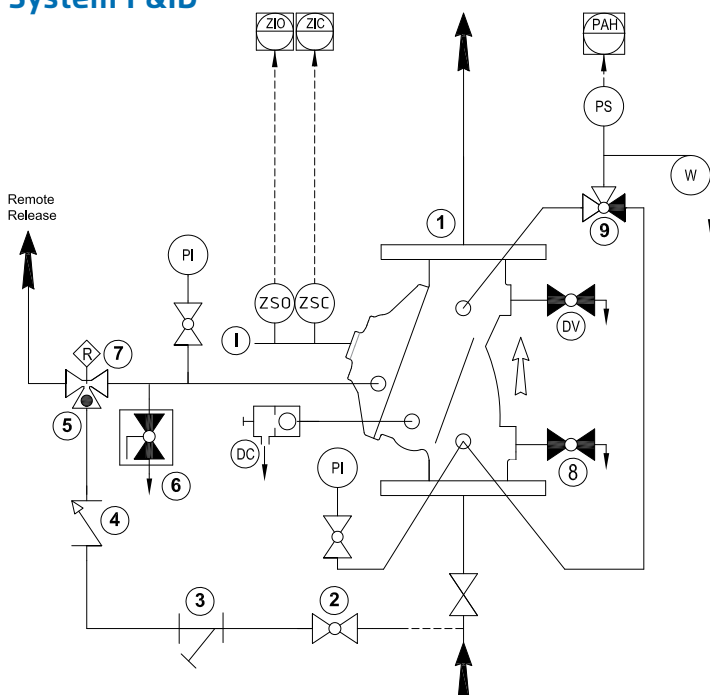

Components

- 1 BERMAD 400Y Deluge Valve
- 2 Priming Ball Valve
- 3 Priming Strainer
- 4 Check valve
- 5 Restriction Orifice
- 6 Manual Emergency Release
- 7 Easy-Lock – Manual Reset

Optional System Items

- ZS Limit Switch Assembly
- I Visual Indicator
- DV Additional Drain/Test Valve
- PS Pressure Switch
- W Water Motor Alarm
- PI Pressure Gauge*
- 8 Drain Valve*
- 9 3 Way Alarm Test Valve*
- DC Automatic Drip Check Valve*

See also Factory Fitted Options under the Valve Code Designations on the last page

*Mandatory for FM approval
(suffix A in code designations on page 4)

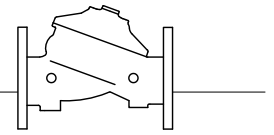

System Installation

A typical installation of the BERMAD model 400Y-1M, features automatic actuation by way of a fusible plug wet pilot line. It can also be triggered manually using the local manual emergency release. When open and fitted with a limit switch the valve can send a feedback signal to a remote valve status monitoring system.

Optional System Items

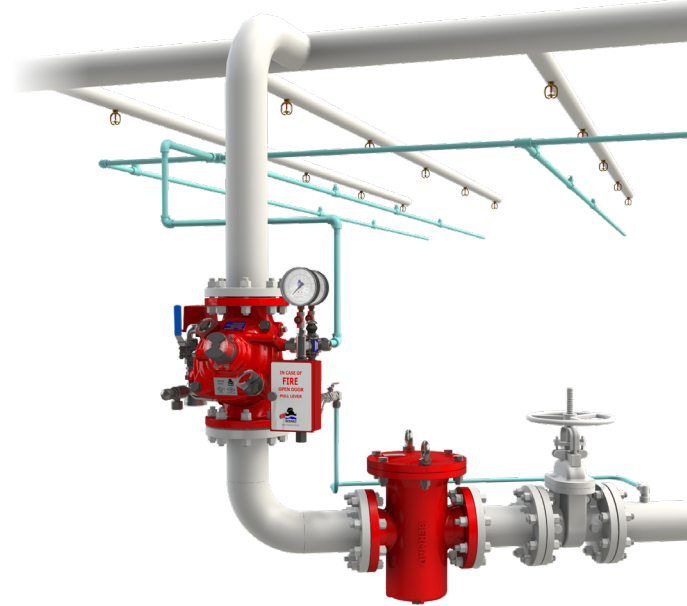
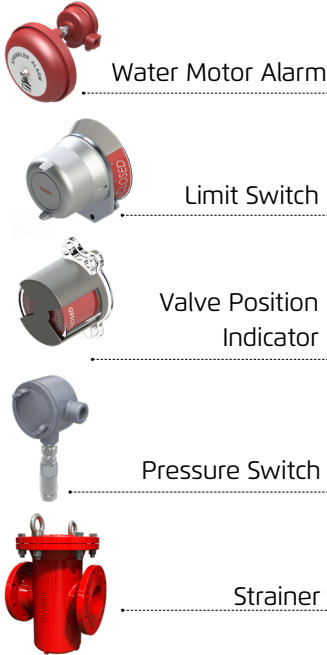

(for Illustration Only)

Maximum Allowable Wet Pilot line Height Above Valve

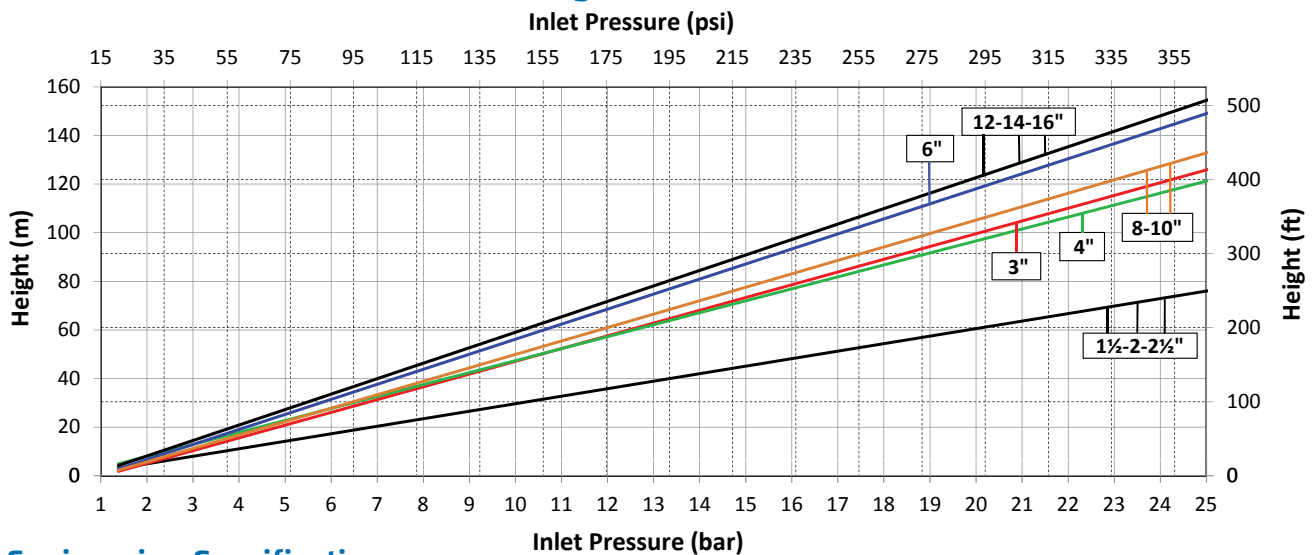

Engineering Specifications

The deluge valve shall be UL-listed and FM-approved, 25-bar/365-psi rated, with a straight-through, Y-type-body. The valve shall have an unobstructed flow path, with no stem guide or supporting ribs.

Valve actuation shall be accomplished by a single-piece, rolling diaphragm bonded with a rugged radial seal disk. The diaphragm assembly shall be the only moving part.

The deluge valve shall include an Easy-Lock latching valve, a Y-type strainer, a ball drain valve, an automatic drip-check with manual override, 4-inch pressure gauges, and a manual emergency release housed in a stainless steel box.

The valve drain socket shall be flanged and have 360-degree swivel.

The valve shall be equipped with a protective-covered, dual-color, rotational position indicator, readable from 50 meters, and with two limit switches enclosed in a protective switch box.

Removing the valve cover for inspection or maintenance shall not require removing the control trim.

The deluge valve and its entire control trim shall be supplied pre-assembled and hydraulically tested by a factory certified to ISO 9000 and 9001 standards.



BERMAD Fire Protection

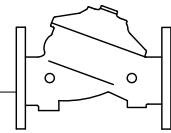

Model FP 400Y - 1M

400Y Series

Technical Data

Available Sizes (inch)

- Flanged - 1½, 2, 3, 4, 6, 8, 10, 12, 14 & 16"
- Grooved - 1½, 2, 3, 4, 6 & 8"
- Threaded - 1½ & 2"

Pressure Rating

- ANSI#150 - 16 bar / 235 psi
- ANSI#300 - 1½" to 10" 25 bar / 365 psi
12" to 16" 20 bar / 300 psi
- Grooved/Threaded - 25 bar / 365 psi

Elastomer

- HTNR - Fabric Reinforced High Temperature Compound - See engineering data

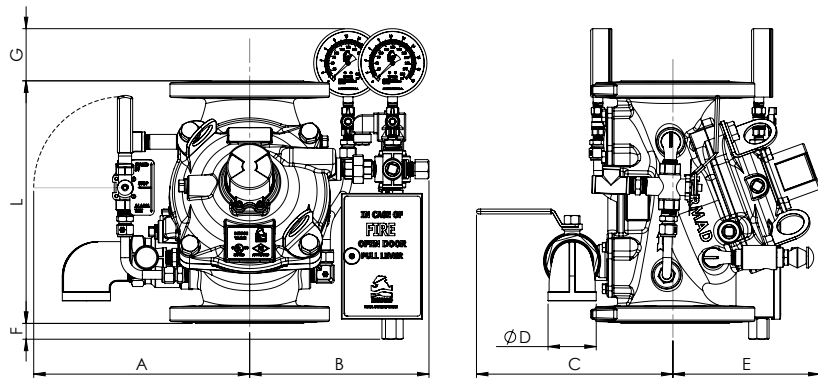

Valve Size	1½" DN40		2" DN50		3" DN80		4" DN100		6" DN150		8" DN200		10" DN250		12" DN300		14" DN350		16" DN400	
	mm	in	mm	in	mm	in	mm	in	mm	in	mm	in	mm	in	mm	in	mm	in	mm	in
L ⁽¹⁾	230	9.1	230	9.1	310	12.2	350	13.8	480	18.9	600	23.6	730	28.7	850	33.5	980	38.6	1,100	43.3
L ⁽²⁾	230	9.1	238	9.4	326	12.8	368	14.5	506	19.9	626	24.6	730	28.7	888	35	980	38.6	1,100	43.3
A	279	11.0	279	11.0	339	13.3	347	13.7	400	15.7	430	16.9	430	16.9	543	21.4	543	21.4	543	21.4
B	191	7.5	191	7.5	249	9.8	247	9.7	314	12.4	342	13.5	342	13.5	455	17.9	455	17.9	455	17.9
C	241	9.5	241	9.5	274	10.8	290	11.4	305	12.0	320	12.6	320	12.6	383	15.1	383	15.1	408	16.1
ØD	¾"		¾"		1½"		2"		2"		2"		2"		2"		2"		2"	
E	120	4.7	120	4.7	146	5.7	158	6.2	228	9.0	295	11.6	295	11.6	441	17.4	441	17.4	415	16.3
F	120	4.7	120	4.7	50	2.0	23	0.9	-	-	-	-	-	-	-	-	-	-	-	-
G	96	3.8	96	3.8	86	3.4	73	2.9	25	1.0	-	-	-	-	-	-	-	-	-	-
Kv / Cv	68 / 79		80 / 92		190 / 219		345 / 398		790 / 912		1160 / 1340		1355 / 1565		2370 / 2737		2850 / 3292		3254 / 3758	
Leq ⁽³⁾ : m/ft	2 / 7		5 / 16		7 / 23		9 / 30		15 / 49		27 / 89		62 / 203		52 / 171		59 / 194		88 / 289	
kg / lb Approx	19.6 / 43.2		21 / 46.3		35.7 / 78.7		45.7 / 101		89 / 196		152 / 336		182 / 402		325 / 717		358 / 790		404 / 891	

Notes: ⁽¹⁾ Refers to the length dimensions for Raised Face ANSI #150, ISO 16 Flanged, Threaded and Grooved valves
⁽²⁾ Refers to the length dimensions for Raised Face ANSI #300 and ISO 25 Flanged valves
⁽³⁾ Leq (Equivalent Pipe Length) refers to turbulent flow in new steel pipe schedule 40, values given for general consideration only
⁽⁴⁾ Dimensions for the trim envelope may vary with specific component positioning

Valve Code Designations

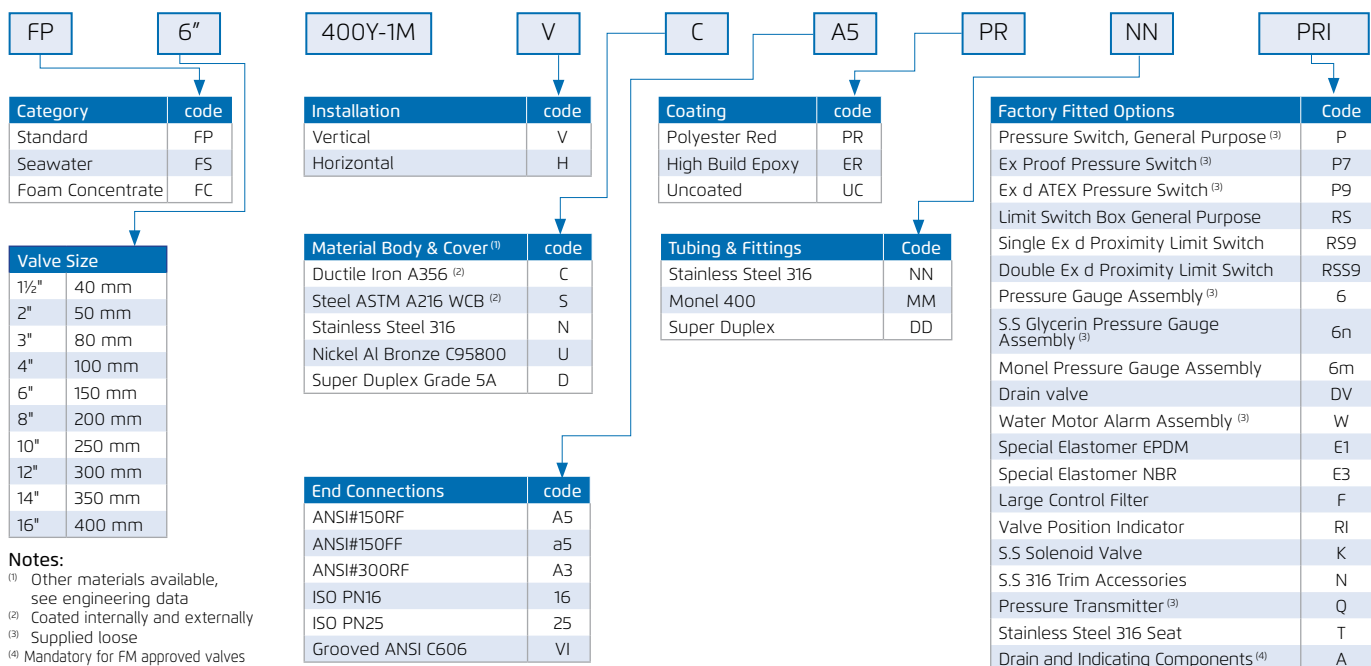

Notes: ⁽¹⁾ Other materials available, see engineering data
⁽²⁾ Coated internally and externally
⁽³⁾ Supplied loose
⁽⁴⁾ Mandatory for FM approved valves



www.bermad.com

© Copyright 2007-2012 Bermad CS Ltd. All Rights Reserved. The information contained in this document is subject to change without notice. BERMAD shall not be liable for any errors contained herein. September 2018